



STAR WARS

75144



 LEGO.com

-  Booklet available in English on:
-  Heft in deutscher Sprache erhältlich auf:
-  Livret disponible en français sur :
-  Folleto disponible en español en:
-  Folheto disponível em português em:
-  A füzet magyarul ezen a honlapon olvasható:
-  如需中文版手册, 请访问 LEGO.com/starwars

About the LEGO® Star Wars™ Design Team

LEGO® Star Wars™ started in 1999, and we have made new models for the product line every year since then. The LEGO Star Wars design team consists of eight model designers, and four graphic designers. The team is a mix of brand new designers with fresh ideas, and experienced LEGO Star Wars designers with many models under their belts.

This is an ideal team for creating new, innovative LEGO Star Wars models, as well as revising and improving previous LEGO versions of classic and iconic Star Wars ships. The focus of our main LEGO Star Wars product line is to make cool, fun, and inspiring LEGO Star Wars models for children.

For LEGO Direct we have the opportunity to make even bigger, more challenging, models with special attention to accuracy and details. These models are fun and exciting to develop, but also a huge challenge! We always do our very best, and hope you will enjoy building this one.

Happy building!



Jens Kronvold Frederiksen
Design Director LEGO Star Wars





About the Snowspeeder



© & ™ Lucasfilm Ltd.

The Incom Corporation is best known for its production of the T-65 X-wing Starfighter, but it also produced an airspeeder that would become one of the main vehicles used by the Alliance during the Galactic Civil War to Restore the Republic in 3 ABY. T-47 airspeeders, more commonly known as snowspeeders, were used extensively in the Rebel Alliance stronghold on Hoth, known as Echo Base. Technicians at Echo Base modified the snowspeeder, used mainly for industrial cargo transport, into a light and fast vehicle for both patrol and combat. The glacial weather on Hoth also forced the Rebel Alliance to adapt the snowspeeder to function in frigid temperatures for extended lengths of time. Heaters were added near the drive units, de-icing nozzles

were added to prevent ice forming on control surfaces, and Rebel technicians also used scavenged Y-wing parts, armour plates, and refitted cockpit modules to further improve the design and defence capabilities.

Due to its small size, the snowspeeder had a crew of just two: a pilot who could handle the speed and manoeuvrability of the airspeeder, and a gunner to fire the AP/11 dual laser cannons and harpoon gun. Because the ship lacked shields, armour plating was added to the hull, and repulsorlift engines were installed to dramatically increase the speed, enabling the snowspeeder to be fast enough to dodge weapons fire.

Despite the snowspeeder's humble creation and patchwork modifications, snowspeeder pilots were inventive enough to use the vehicle to its full potential. When they realised laser fire was ineffective against more advanced Galactic Empire vehicles, snowspeeder crews used the harpoon gun and tow cables to tie up the massive legs of the Galactic Empire AT-AT walkers and disable or bring them down entirely.

T-47 airspeeders also proved useful to the Rebel Alliance forces in more than just the frigid climate of Hoth. Rebel Alliance technicians modified the multi-faceted cargo transport ship into multiple incarnations besides the snowspeeder. The swampspeeder, for example, was rebuilt with flotation gear and water-tight seals. Other variants included the sandspeeder, which was customised with advanced air filters to keep out the sand and engine cooling units to combat the scorching desert sun; and skyspeeders, which had pressurised cockpits and more powerful repulsorlift engines for higher altitudes.

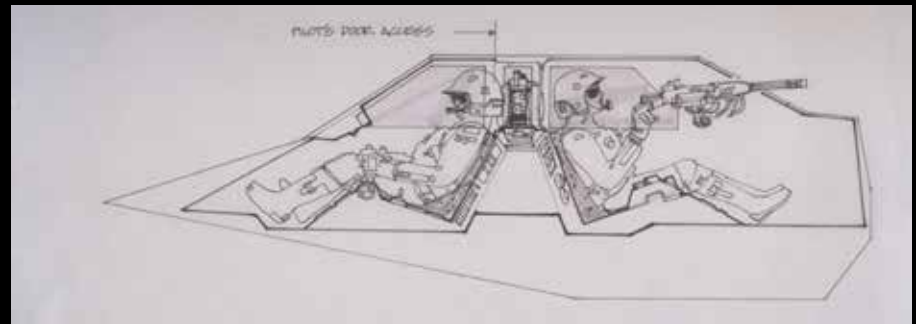

© & ™ Lucasfilm Ltd.

Facts/Specifications

Snowspeeder Facts

Manufacturer.....	Incom Corporation
Model.....	T-47 airspeeder
Class.....	Airspeeder/Repulsorcraft

Technical Specifications - Modified T-47 airspeeder

Length.....	5.3 metres
Maximum speed.....	1,100 km/h
Maximum altitude.....	175 metres
Armament.....	2 CEC AP/11 double laser cannons Ubrikkian Mo/Dk energy harpoon and tow cable Light repeating blaster cannon
Engine Unit.....	Karydee KD49 repulsorlift engines
Crew.....	1 pilot and 1 gunner
Cargo capacity.....	10 kilograms



© & ™ Lucasfilm Ltd.

Meet the Model Designer

Jordan David Scott

Q: How many LEGO® *Star Wars*™ models have you designed?

A: The UCS snowspeeder will be the fifth LEGO *Star Wars* model that I have worked on which has been released.

Q: What kind of reference material did you use to begin designing the snowspeeder?

A: Firstly, I looked at the previous UCS snowspeeder that was designed back in 2003 to see what inspiration I could take from that. Secondly, I had various images and film stills from our *Star Wars* books and *Star Wars: The Empire Strikes Back* movie.

Q: How was designing the snowspeeder different from your work on other LEGO *Star Wars* models?

A: I think the main difference is the level of detail that you can put into the UCS models. These larger models allow for more complex building techniques and levels of detail which I personally love building into the models I work on. My favourite detail in the UCS snowspeeder was the use of LEGO minifigure ski blades on the underside to resemble part of the cooling fins. These UCS models are also meant to look as accurate as possible to the real vehicles. This means difficult angles or features can become quite tricky to recreate; the back window of the cockpit was particularly difficult to build as it slopes in three different directions, but also has to support the hinge connection for the cockpit.



Jordan David Scott

Q: The front of the snowspeeder has an easily recognisable, angled bow. Was this a challenge to recreate using LEGO bricks?

A: The angles were very tricky to achieve and this was something I wanted to do differently from the previous UCS snowspeeder. Back in 2003 we did not have as many elements that could achieve this look, and so it was built using angled bricks. Now, thanks to the miniature ball joints, I was able to achieve a more sleek and accurate front.

Q: How did you plan the design for the snowspeeder? Did you use artist sketches or film stills to inspire your design of the model?

A: Most of my inspiration came from film stills and cross section illustrations in *Star Wars*™ encyclopedias that we have in work, and use a lot for reference.

Q: There are smaller versions of the snowspeeder in the LEGO® Star Wars Battle of Hoth set; how is this larger model similar to those smaller snowspeeders?

A: I think one thing that is similar even though the sizes are so different is the functionality; the UCS model has several functions that are similar to the smaller version, for example, the rotating rear gun and moveable air brakes. These functions make it a more interesting model and building experience.

Q: As a vehicle used for reconnaissance and defence, snowspeeders are equipped with both weapons and speed. How do these elements feature in the final design?

A: The high-speed nature of the snowspeeder is apparent in its compact design, using sharp angles to make it more streamlined; this was something I was very conscious about whilst designing the model, by making the underside less bulky and brick heavy. Another part I wanted to build as accurately as possible were the turbo lasers, which are designed to slant inwards so that they will focus fire at a certain point. This was a lot harder to build than I thought and at first glance it might not seem apparent, but they are in fact built on a very slight angle of about 10-15 degrees.



Q: Is there a specific feature of the model that you enjoyed designing the most?

A: I had a lot of fun designing the interior of the cockpit, like the back-to-back seats and all the small controls surrounding them, which were challenging to fit inside such a small space but just added so much detail.

Q: With a rotating rear gun, an opening cockpit, and moveable air breaks, there are many moving parts to this model. How did you create the design to ensure stability?

A: All of the moving parts on the model are fairly small builds, which meant it was easier to stabilise them. I did have some challenges with the cockpit as the two new window elements that I used to create it were very large and heavy and we wanted to ensure you could display it with the cockpit open or closed.



Meet the Graphic Designer

Marie Sertillanges

Q: Are these the first LEGO® Star Wars™ minifigures you've designed?

A: No, my first minifigure design was the last Naboo Pilot from 2015. The minifigures for this set are actually mostly existing designs. We decided to keep them since they are really iconic, whilst improving them with decorated arms. It was, however, my first time designing minifigure arms.

Q: What do you use to begin designing the decorations for LEGO Star Wars minifigures?

A: My very first step is to gather all the visual references I have for the character and try to build the big picture of their looks. Then, I choose which LEGO colours I will use for the torso, arms, legs and hands. The next step is to sketch the general shapes of the design, to translate the look of the character into LEGO style. To finalise the design, I go back and forth from the references to the minifigure sketch until I am satisfied, or until I am out of time!

Q: Minifigures are very small, what are some of the challenges in creating designs that are both detailed and easy to understand?

A: To ensure that the design is full of cool details but still readable, I start with extra simple and big shapes. Having the right composition at any time of the design is essential and it is easier to achieve when you have few elements. From there I will 'cut down' these big shapes to more detailed ones, as you would do while sculpting. The hard part is to choose the right details in order to really capture the character's look or personality!



Marie Sertillanges

Q: What do you use as reference material for designing the minifigure decos? Film stills? Licensed art?

A: For the old *Star Wars* movies we use mainly film stills or photos from production, directly from LucasFilm. At that time in the film industry, behind the scenes documentation was not as complete as nowadays, which makes it a bit harder for us to collect all the accurate references.

Q: The flight suits worn by the characters in the *Star Wars*™ films are incredibly detailed. How do you choose which details to focus on when designing the art for the minifigures?

A: The design of these pilots was made way before I became a LEGO® Graphic Designer, but I can speak about my general way of approaching a minifigure. When I design a character, I choose what makes him/her really special, what defines him/her. The layering and materials are important on the Rebel Uniforms, and wrinkles, for example, can be used to show material qualities as well make a character less orderly or more dynamic. I always bear in mind that you cannot and don't need to draw everything like in real life. Think of looking at reality through a LEGO filter.

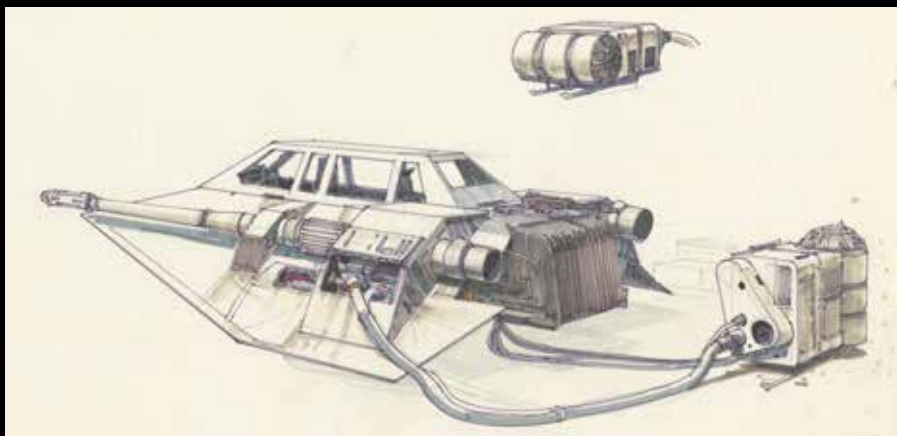

© & ™ Lucasfilm Ltd.



© & ™ Lucasfilm Ltd.

Q: How do these minifigures compare to others you've designed?

A: Most of the minifigures we design are only decorated on torso, head and legs. Decorating on the arms is only reserved for special minifigures. I designed both main heroes and secondary characters like Zev Senesca. Compared to the main heroes, these generic characters are more challenging to design because you have to look closer to find what differentiates them from the crowd. To be honest, I prefer working on side characters as they seem plain at first sight but hold unique stories when I dig deeper.



Meet the Art Director

Michael Sion

Q: Have you worked on package design for LEGO® Star Wars™ before?

A: I started working on LEGO *Star Wars* in 2009 and oddly enough, my first packaging was a set of battle packs with minifigures from the planet Hoth. Now, six years later, I'm back on Hoth with the snowspeeder.

Q: What kind of reference material do you use to begin designing the package art?

A: One of the great things about *Star Wars* is the amount of fan-based material that is out on the web. I like to scan the internet for a while to immerse myself in the world of *Star Wars*. Usually the model has an iconic scene from the movies that I always try to refer to. Then, while making the packaging, never underestimate the use of making sound effects while creating the packaging fronts.

Q: The snowspeeder is a *Star Wars* vehicle that features predominantly in the Battle of Hoth, which takes place in a very snowy environment. How did you ensure that the white vehicle stood out from the white environment?

A: Colour, lasers, explosions and smoke! Explosions have made my life much easier on a number of occasions.

Q: What are the first steps you take when you begin the package design for a new LEGO *Star Wars* set?

A: I always start with the brief to see what the LEGO *Star Wars* product team wants to show. Then I 'play study' the model to get a feel for its potential.



Michael Sion

Q: Are there specific techniques you use to depict the features and functions of a particular set on the box art?

A: I invariably struggle with function shots. Luckily, we get the models in a 3D program so we can rotate them instead of having to go right to photography. It's predominantly trying to get across the idea of cause and effect, for example; showing a set feature that involves pushing or pulling a section of the model and the resulting action. I also try to use depth of field to de-emphasise the parts of the model which are only there for context.

Q: What kind of challenges do you face when designing art that will be specifically used for packaging design? How is package art different from other forms of design work?

A: Sometimes challenges can be unexpected, for example, there are times when a model changes during the design so it is important for us to be flexible with our whole team. Additionally, because we have LEGO® sets all around the world, once in a while we need to put different translations of words or messages on the packaging which also alters the design slightly. Our team works well together however, so any challenges we come across we usually solve quickly, so we are able to produce something amazing to share with LEGO Star Wars™ fans everywhere.

Q: When you create packaging art, is your goal to recreate iconic scenes from the Star Wars film franchise, or are you more focused on displaying the unique qualities of the set?

A: First and foremost is the LEGO model, but I try to stay as authentic to the movies as possible.

Q: Is there a part of the design process that you enjoy most?

A: Beginning any new project is very exciting, and I enjoy the first phases of design the most. Before anything is actually started, all you have is the potential to make something, and that to me is the part of the project that is the most fun. Turning over in your head what the scene can be and how to get it on paper is a creative process that I can have a lot of fun with, and watching something be created from the beginning all the way to the end is a fascinating transformation.



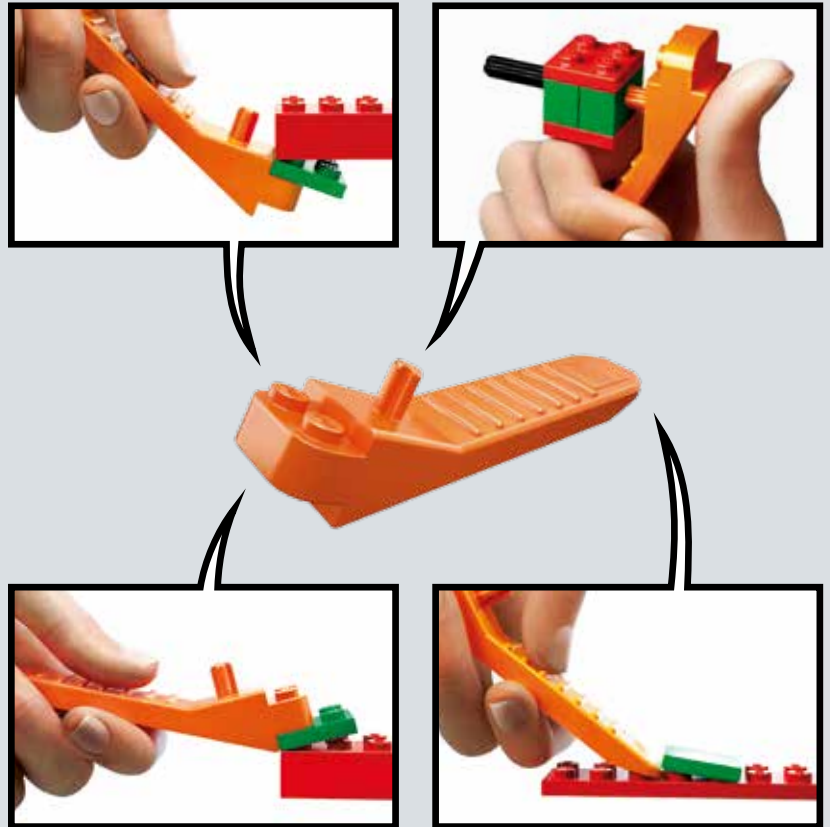
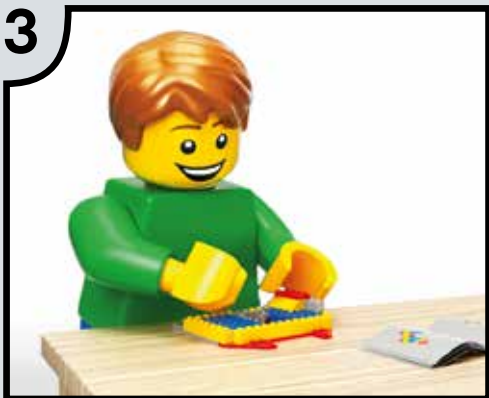

LEGO.com/brickseparator



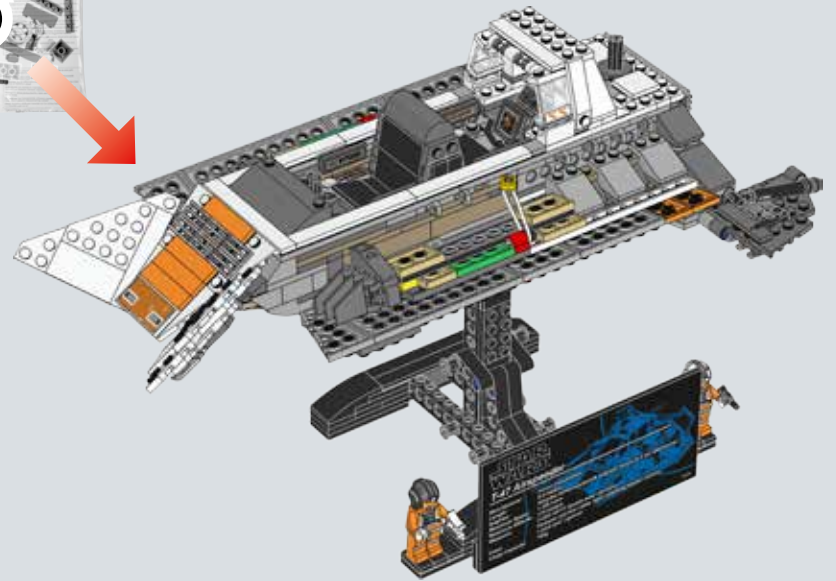
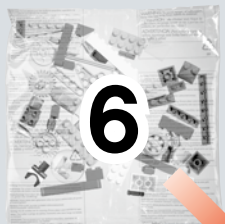
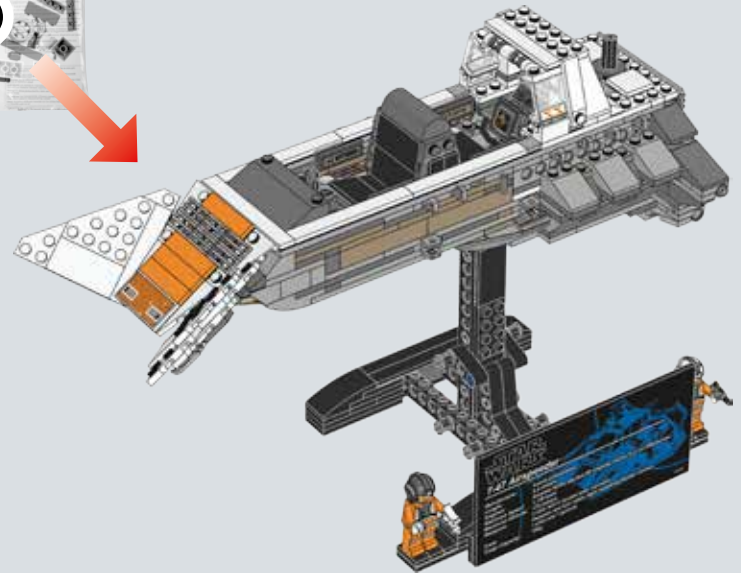
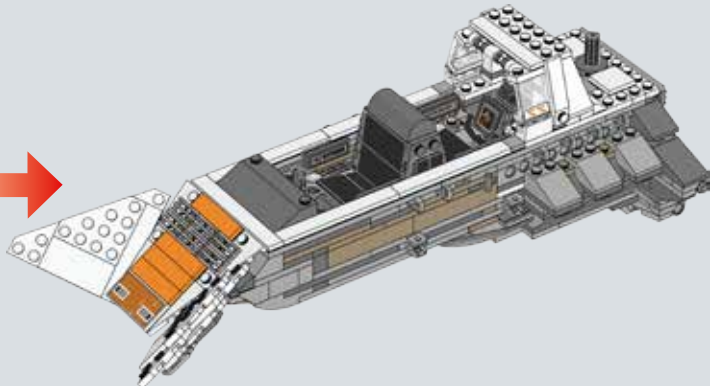
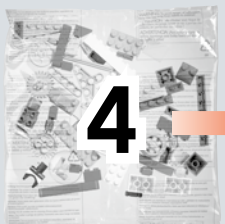
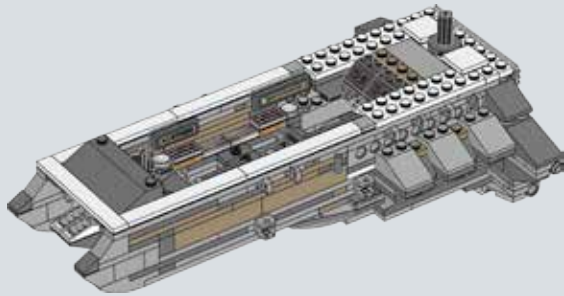
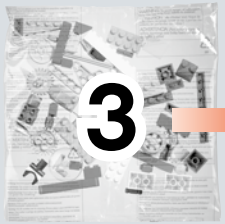
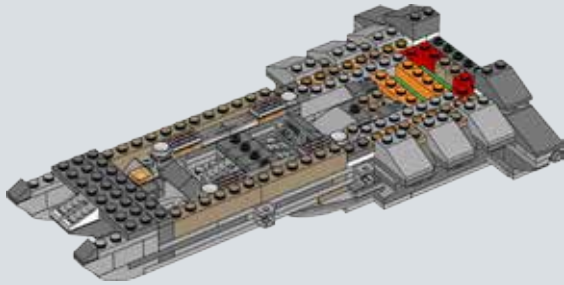
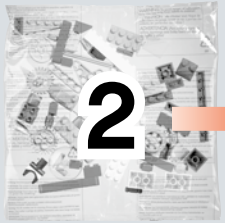

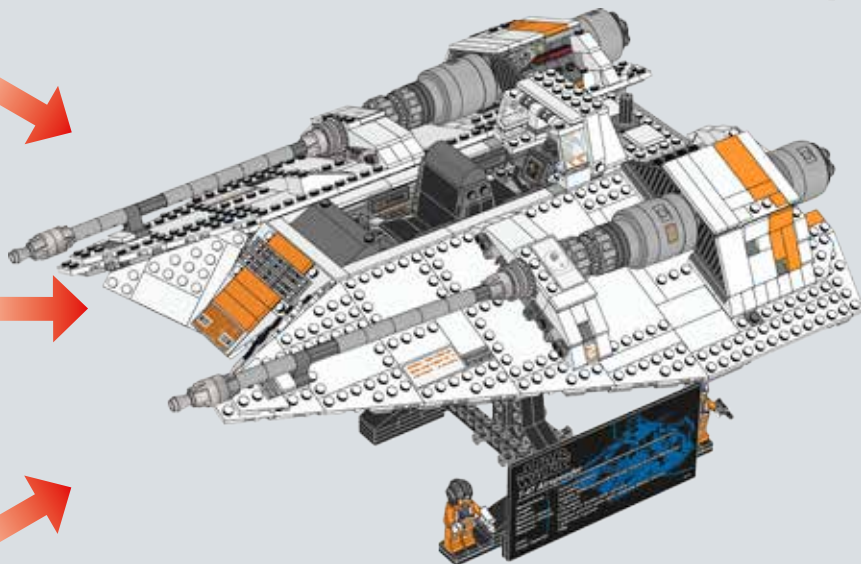
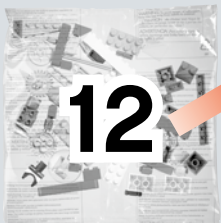
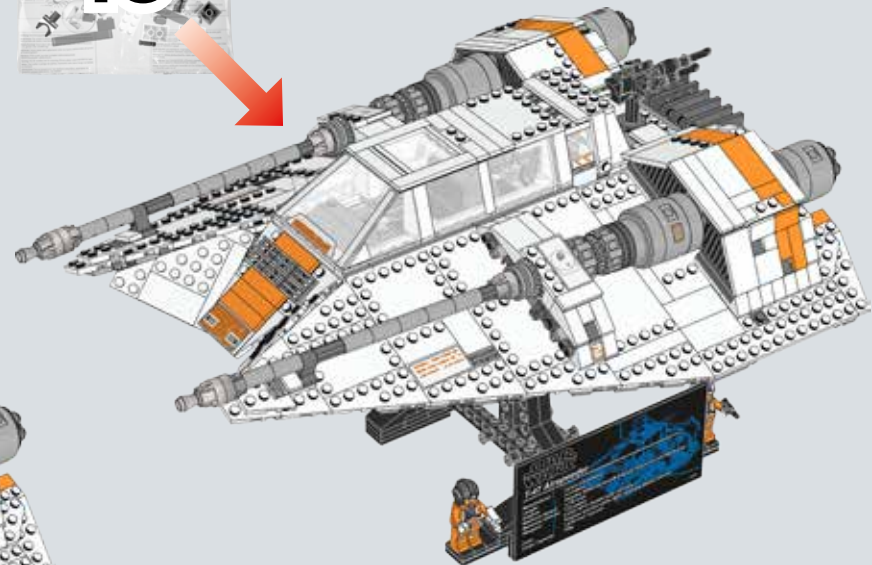
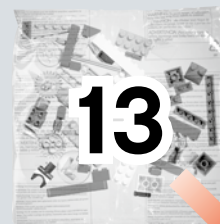
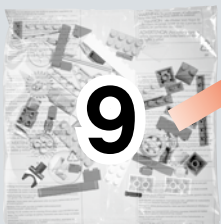
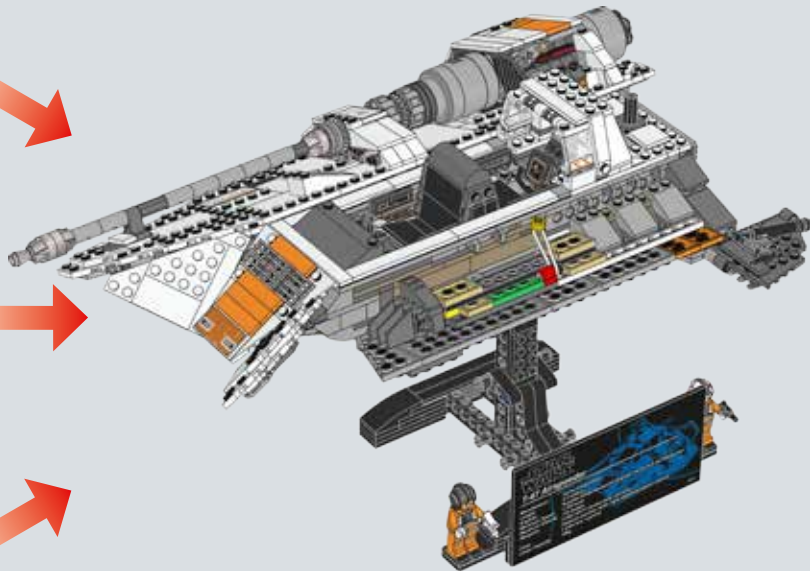
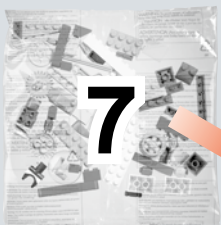

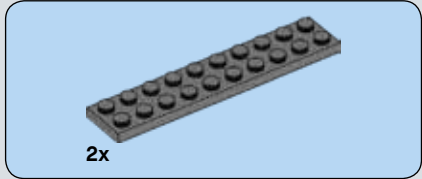
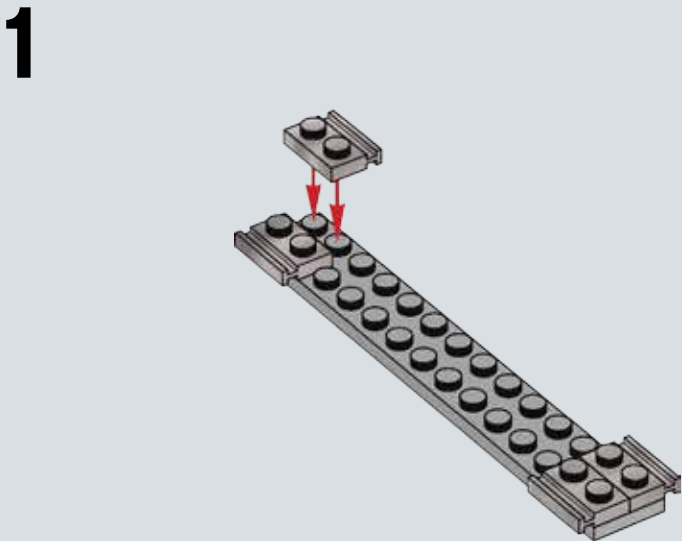
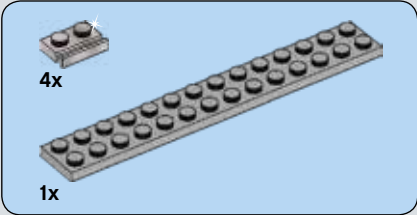
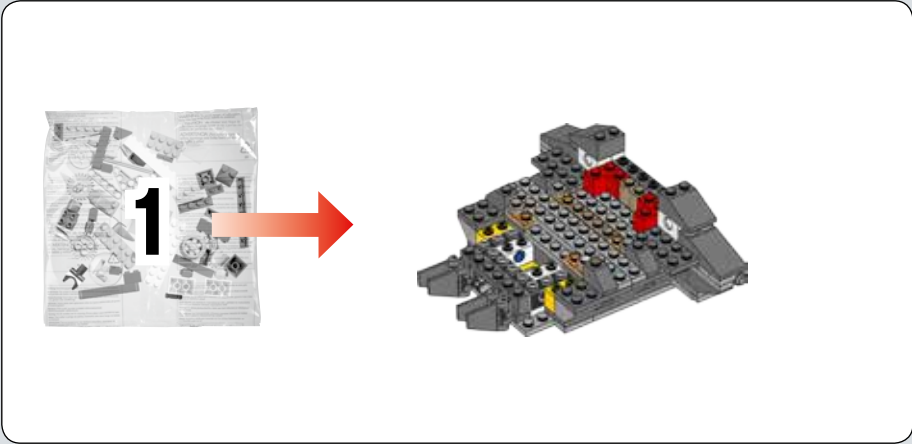

2

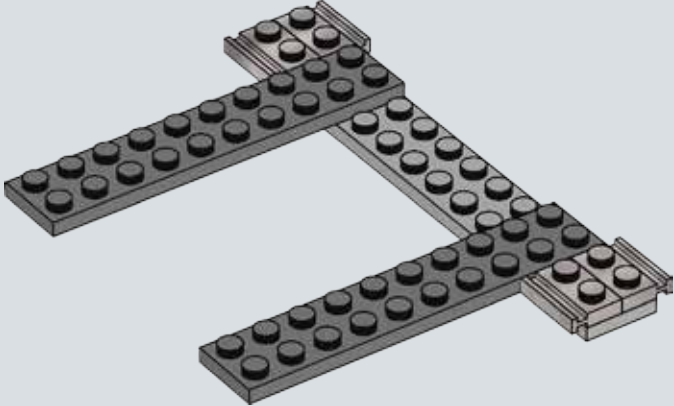

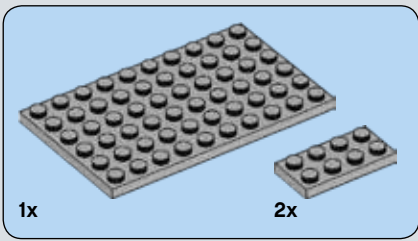

3

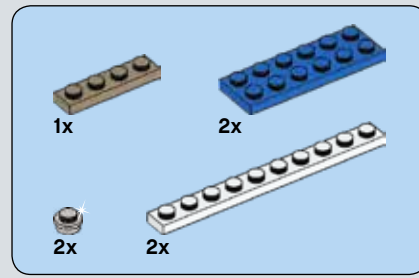
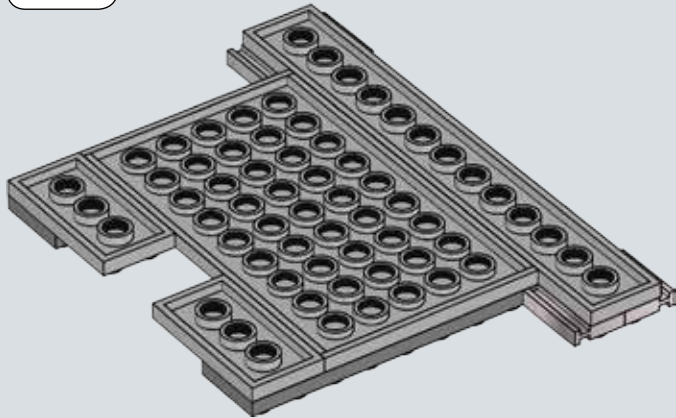
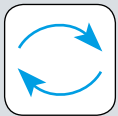

4

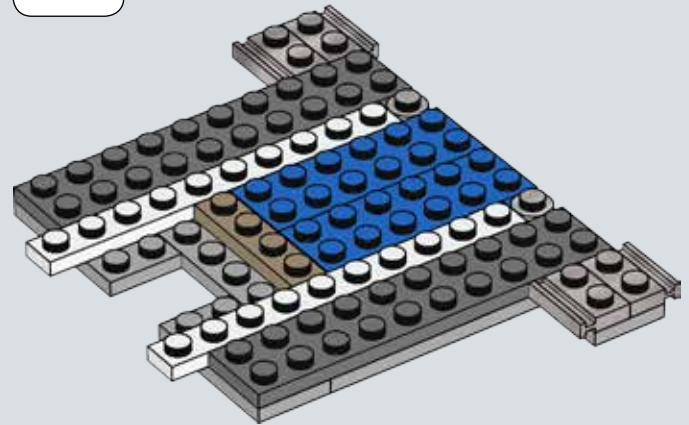
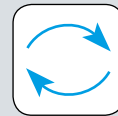

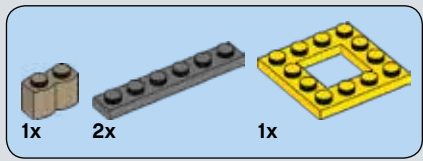

5

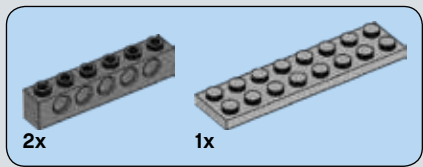
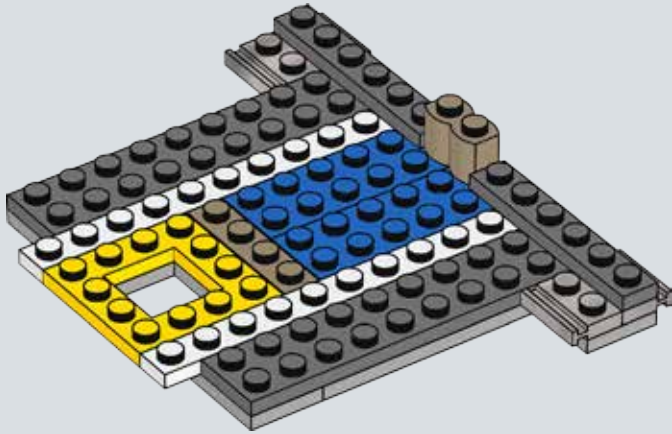

6

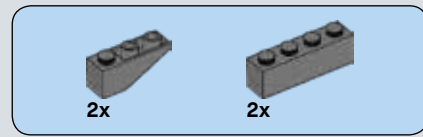
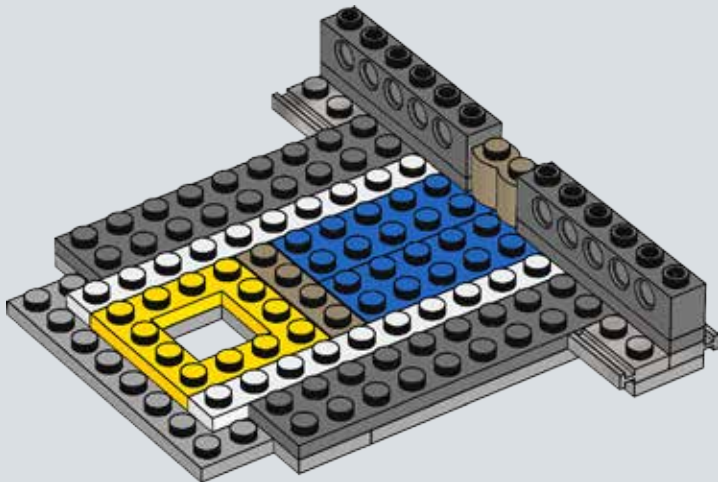

7

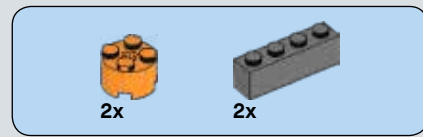
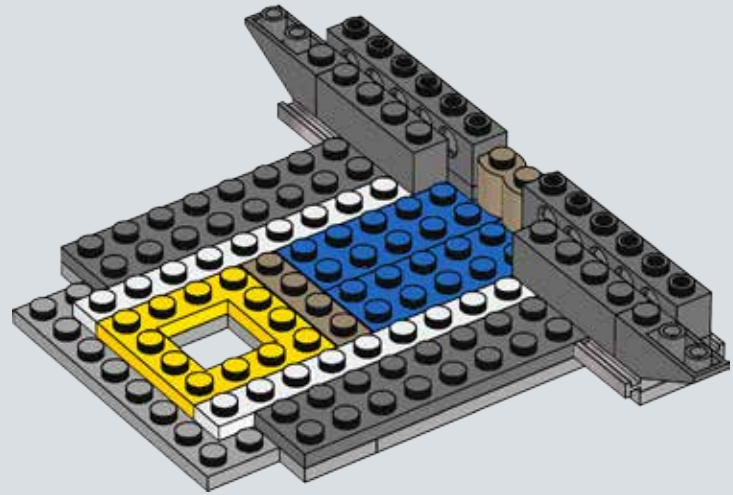

8

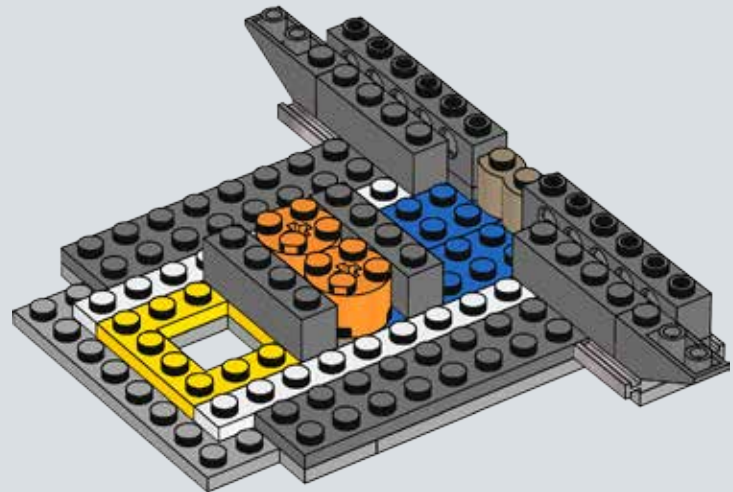

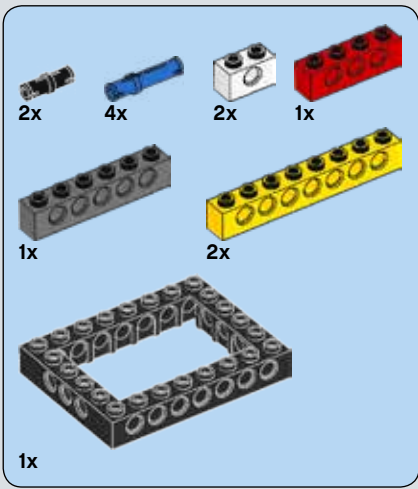

9

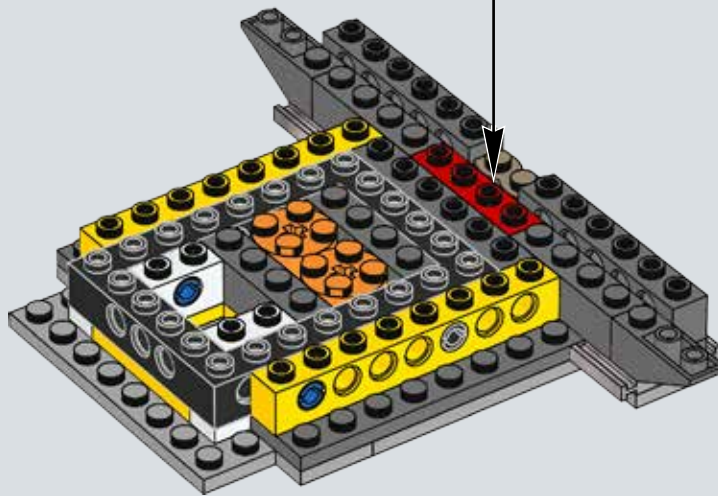
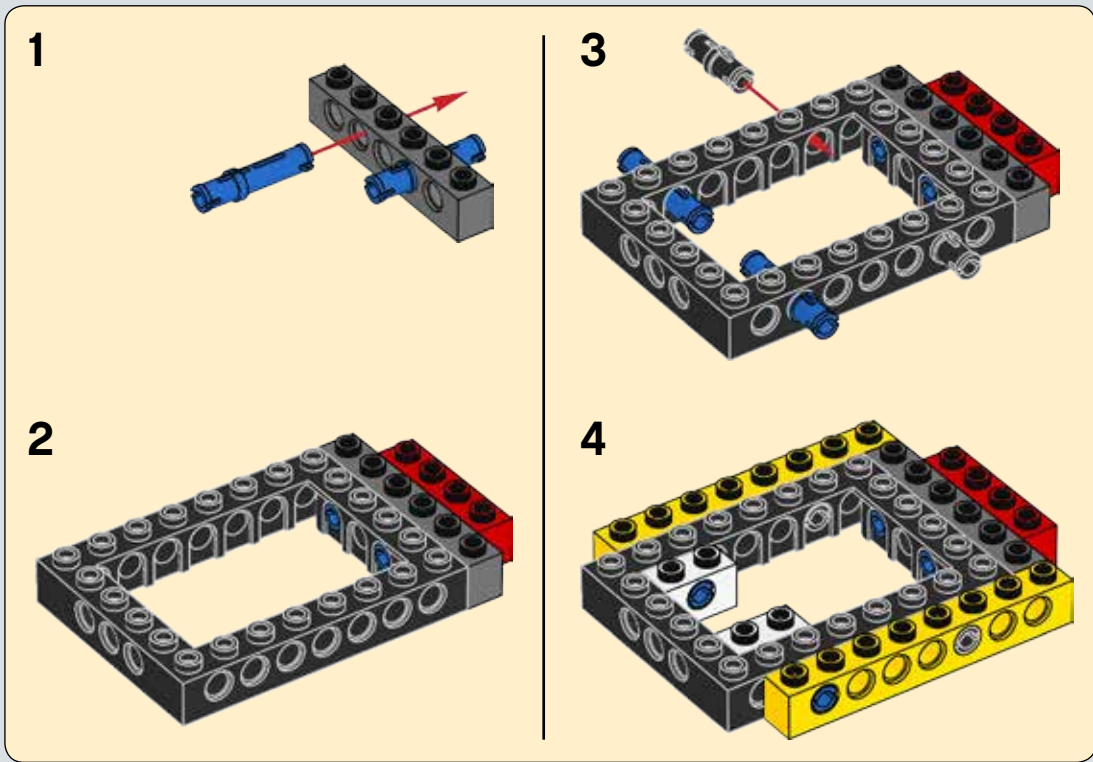



6x

10

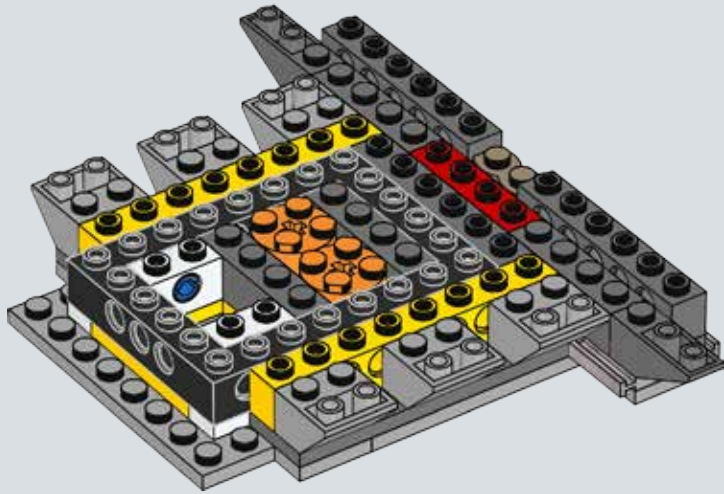

4x



4x

11

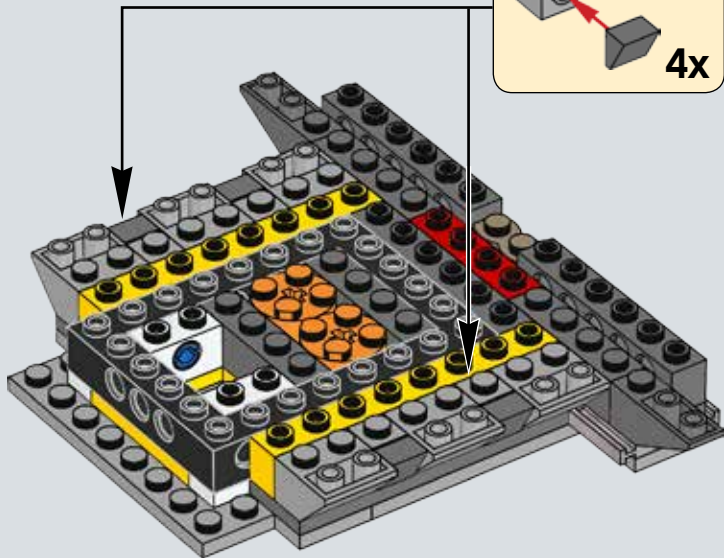

2x



1x

12

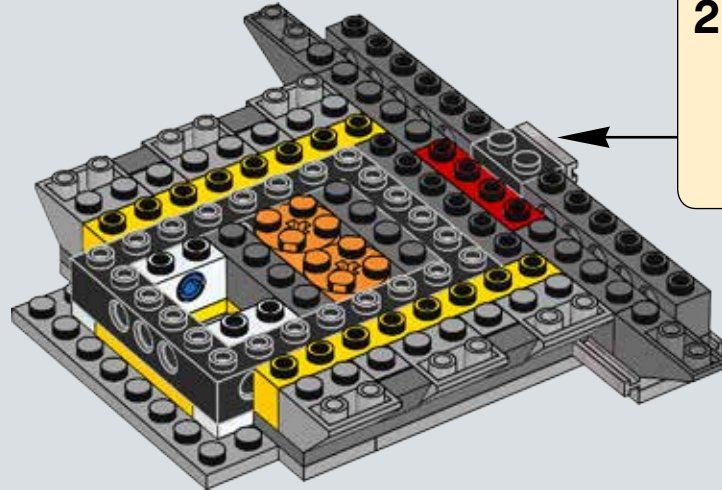

1



2

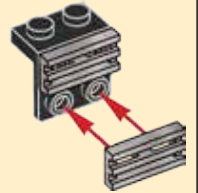

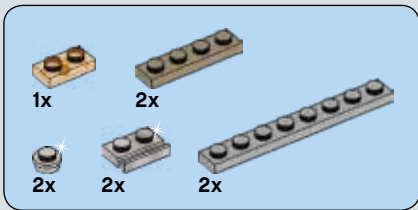

13

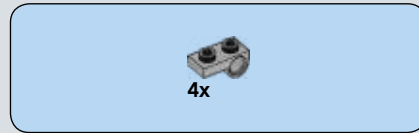
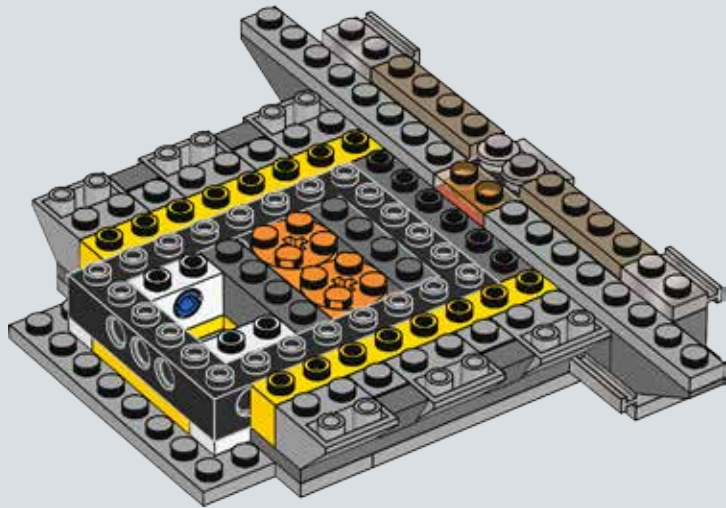

14

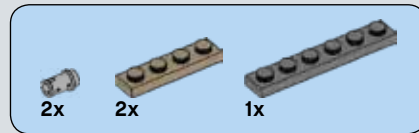
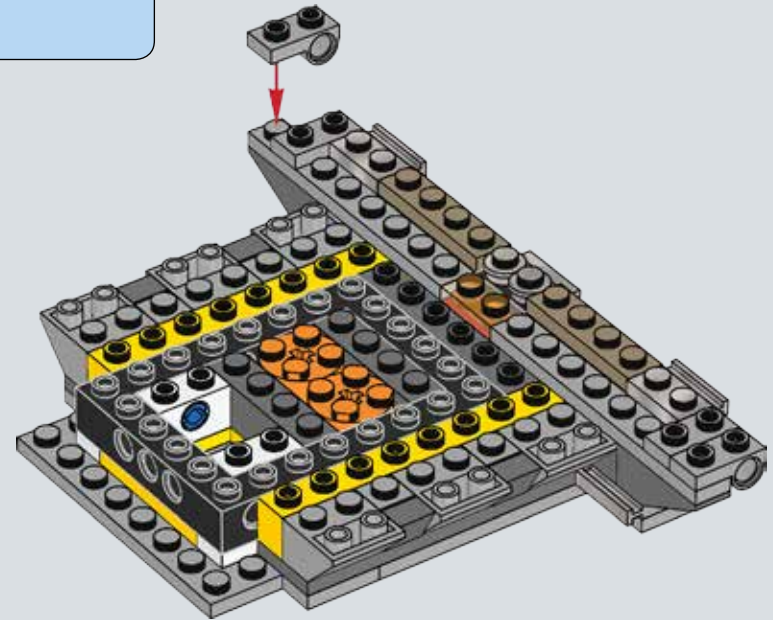

15

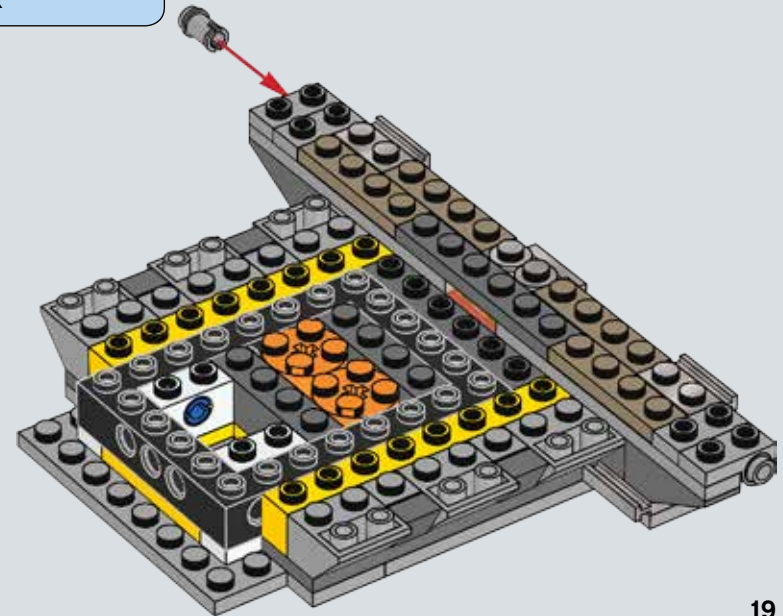

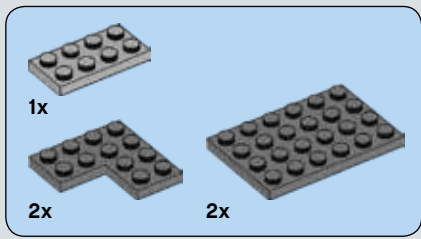

16

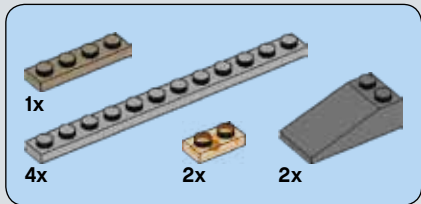
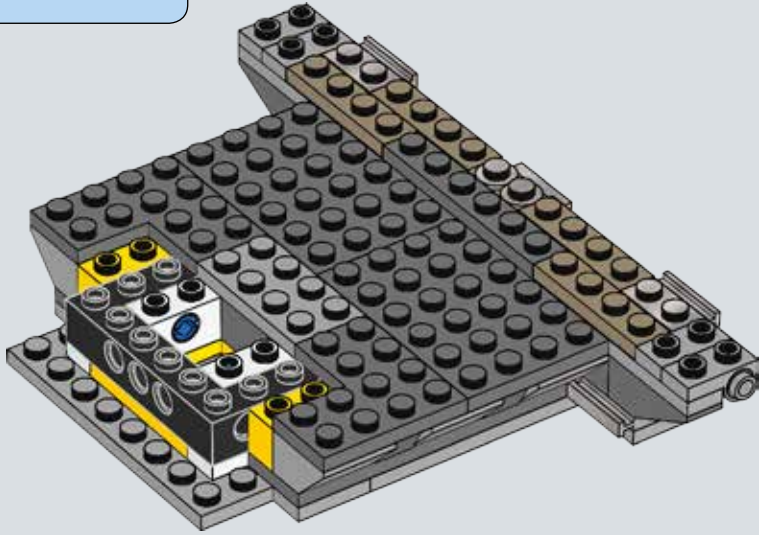

17

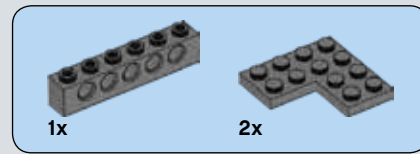
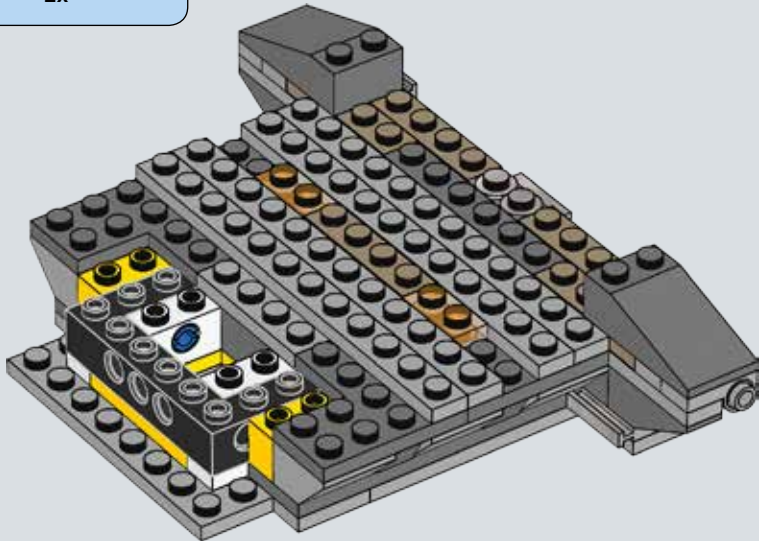

18

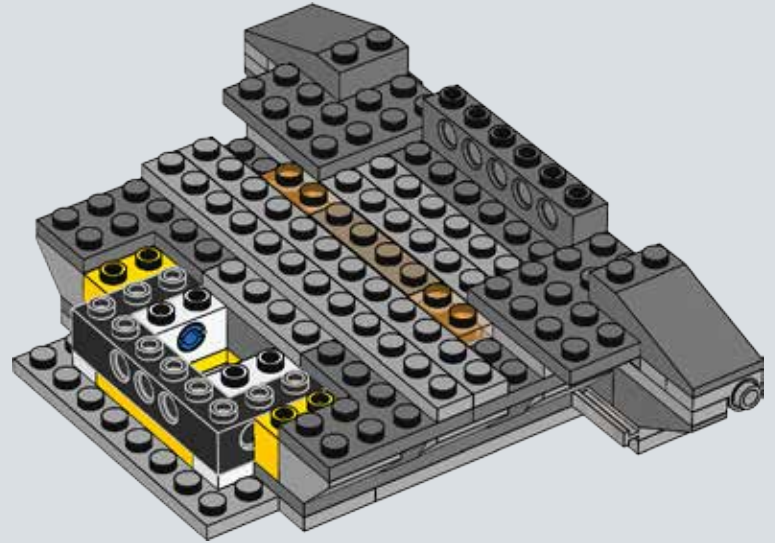



19

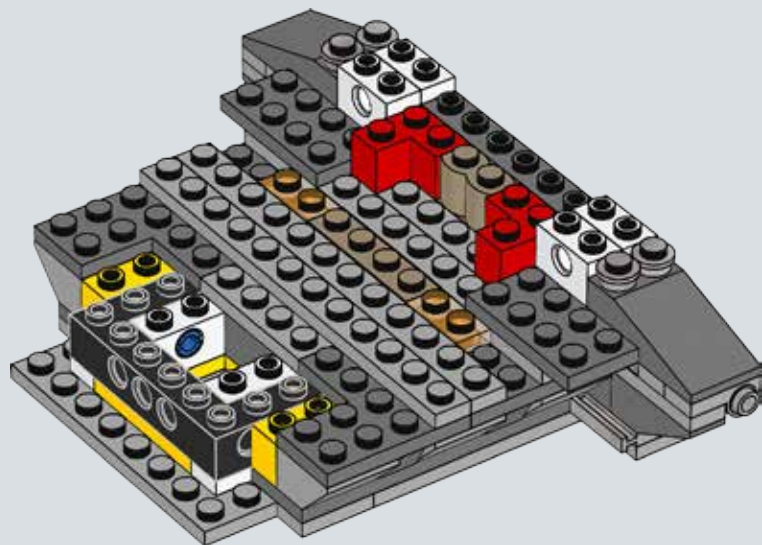

20

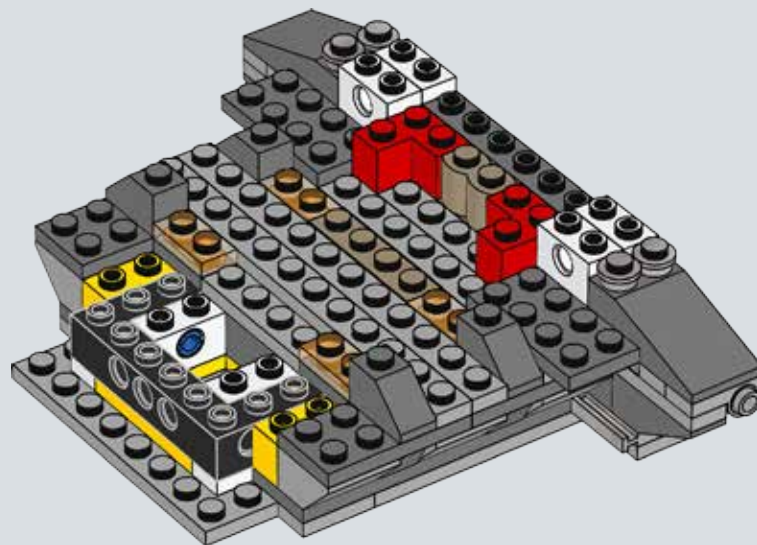

21

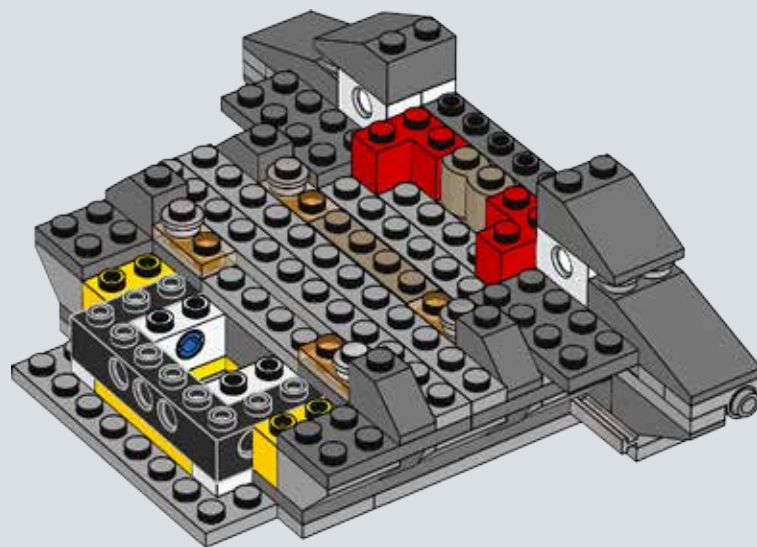

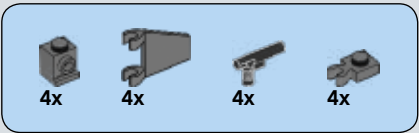

22

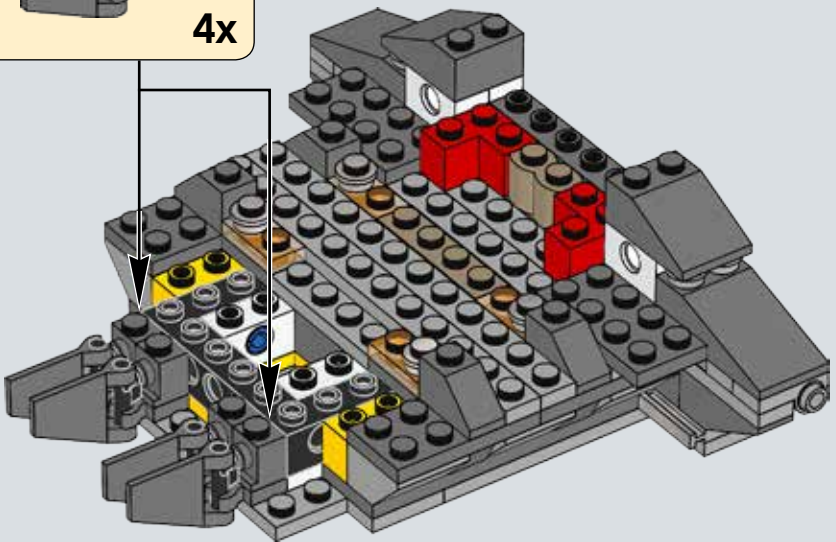
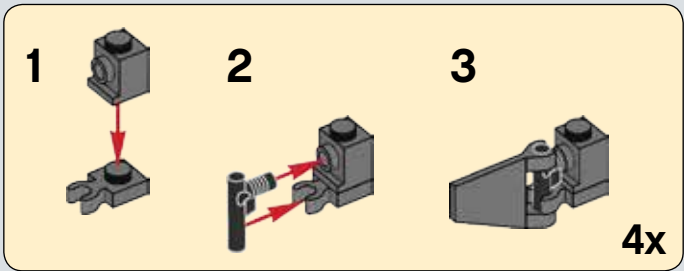

23

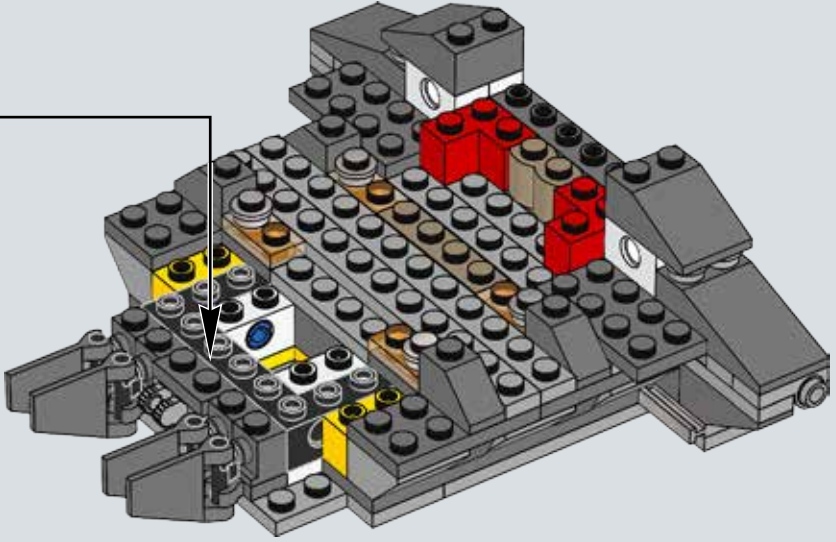
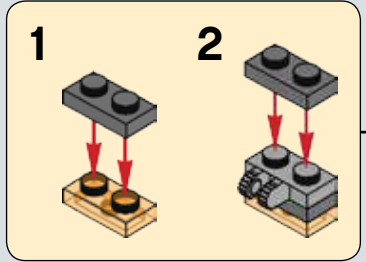

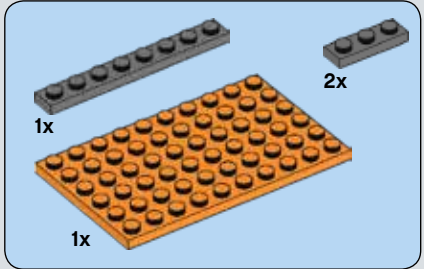
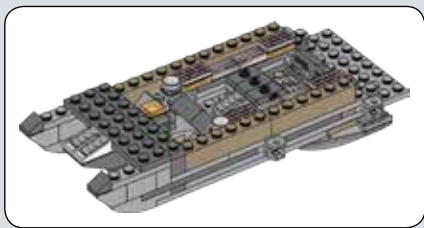
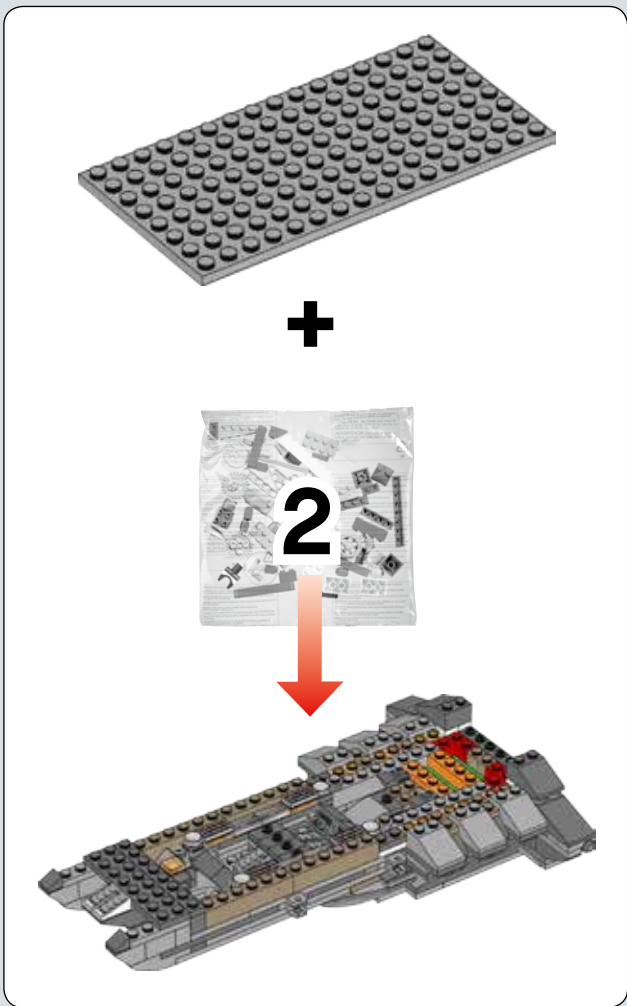

24

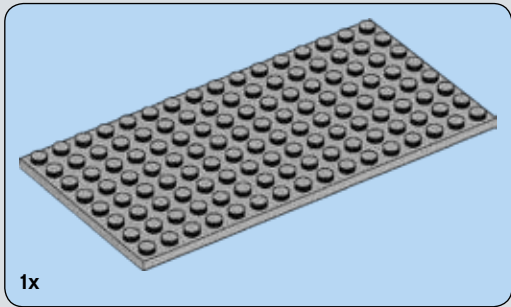
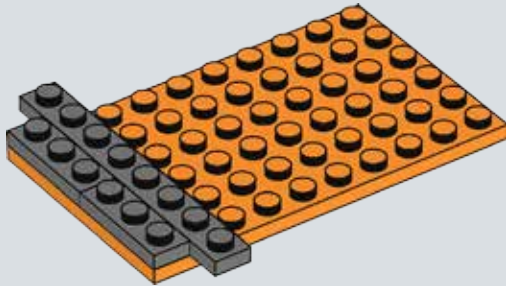

25

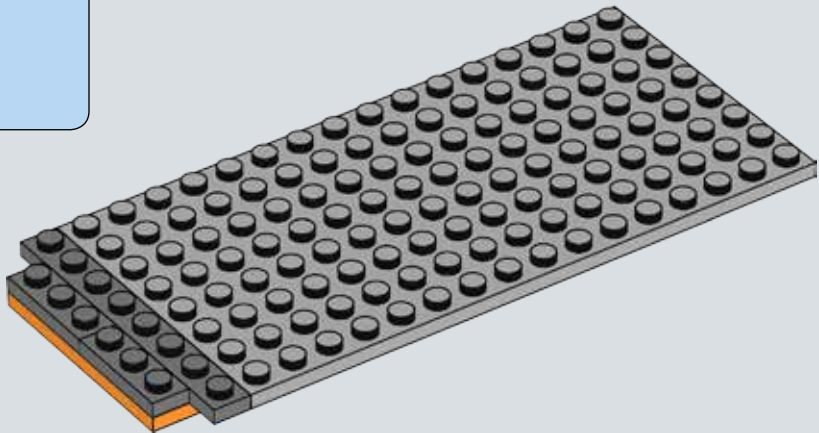

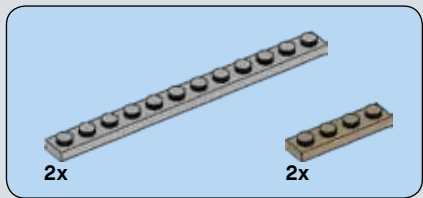

26

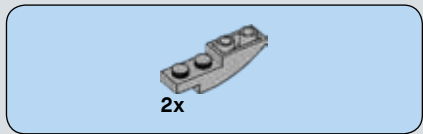
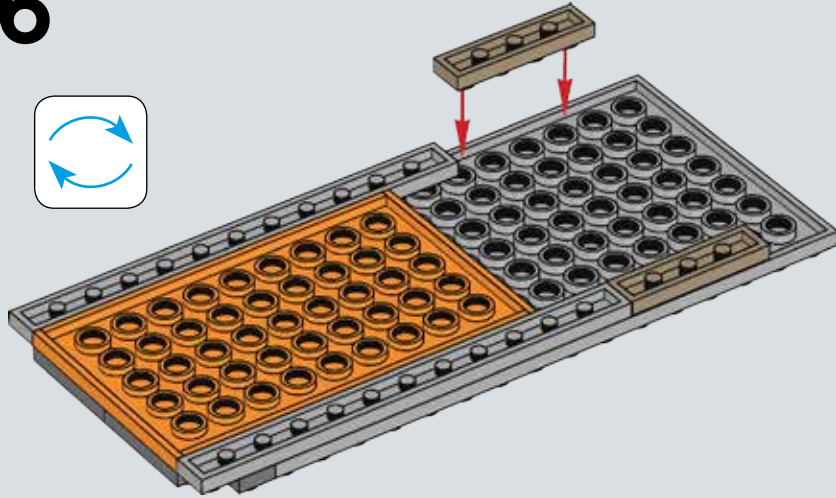

27

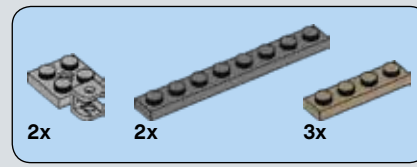
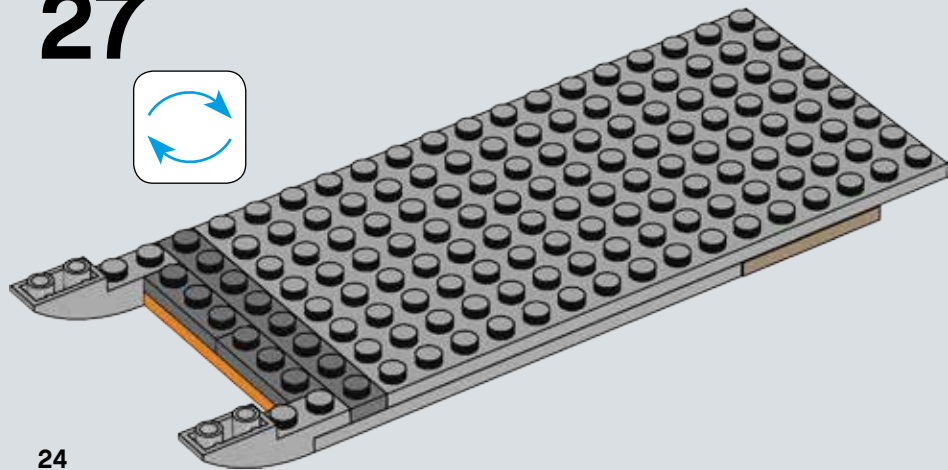

28

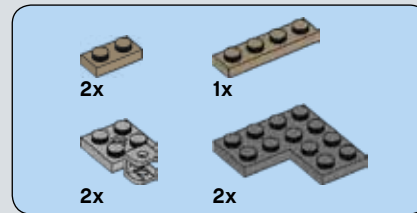
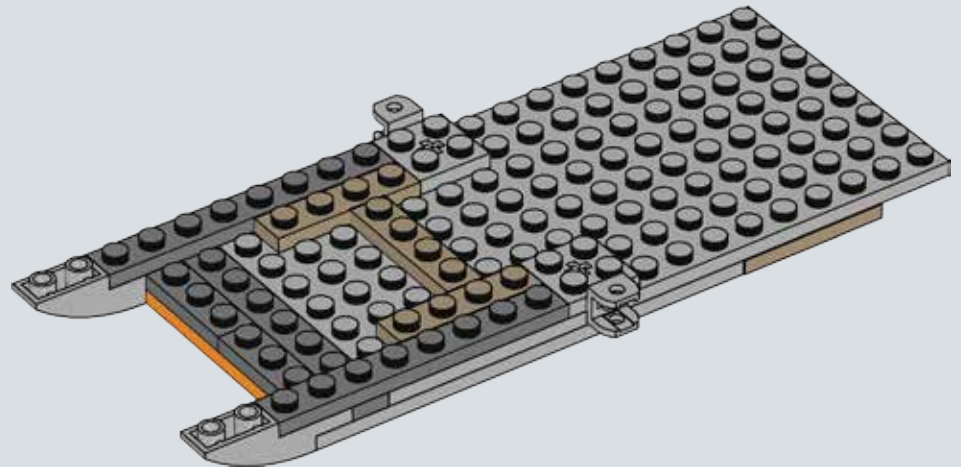

29

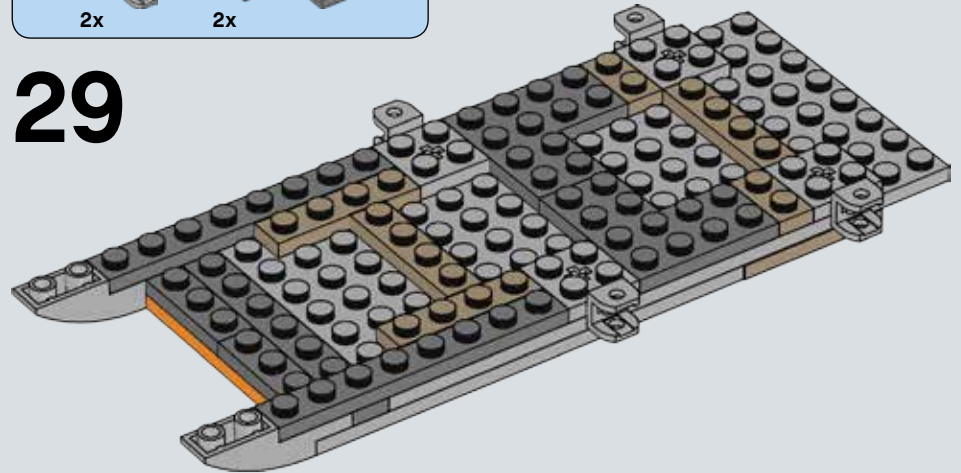

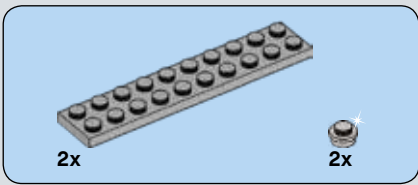

30

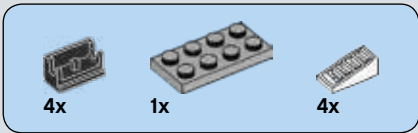
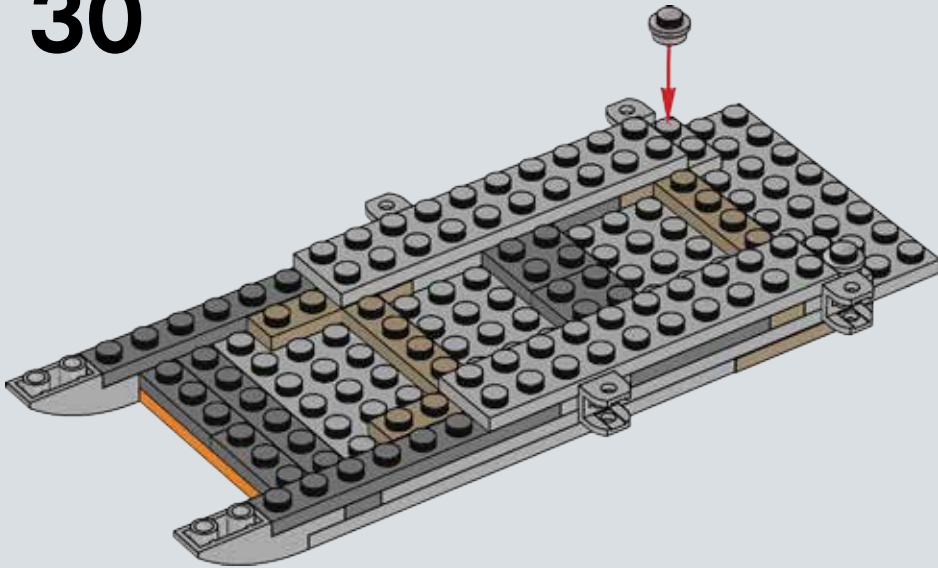

31

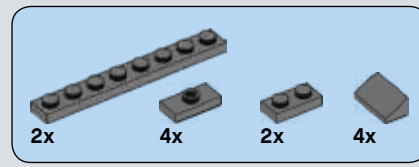
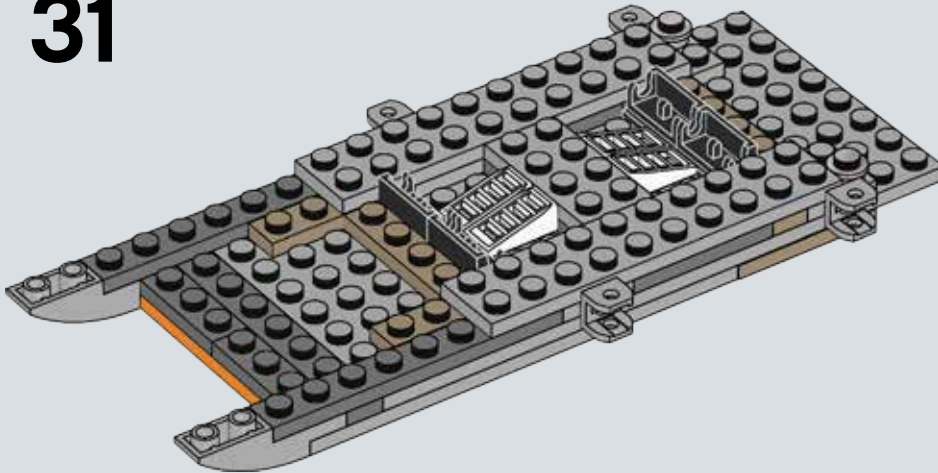

32

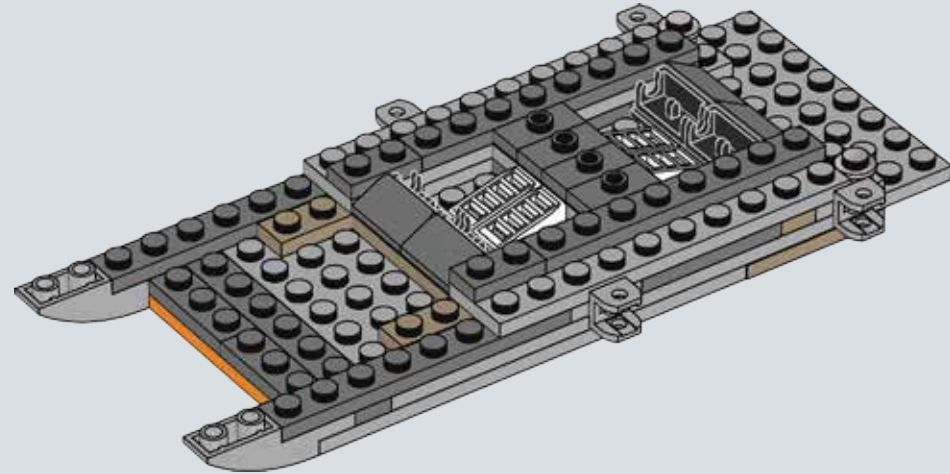

33

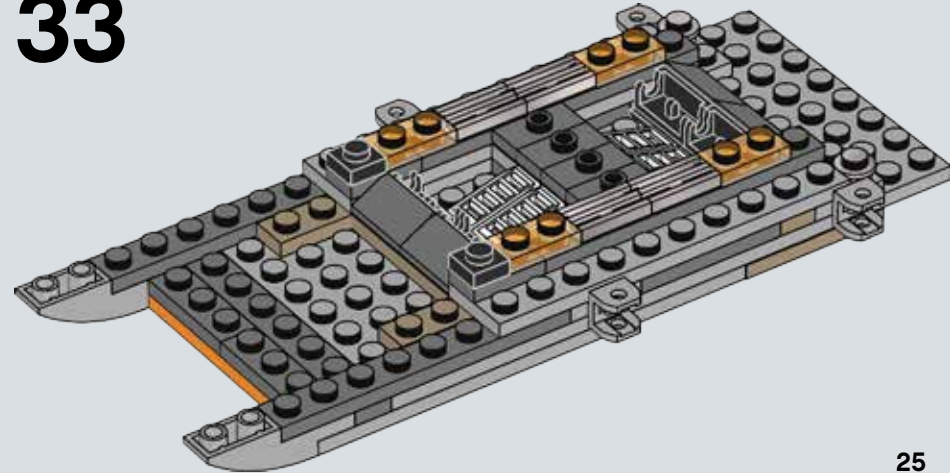



34

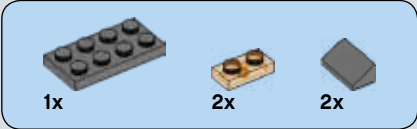
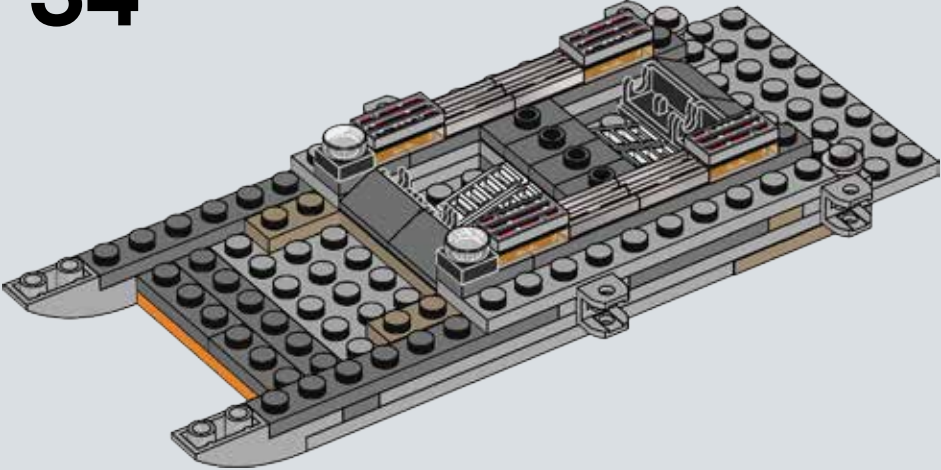

35

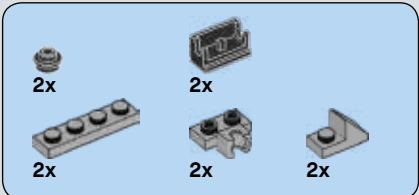
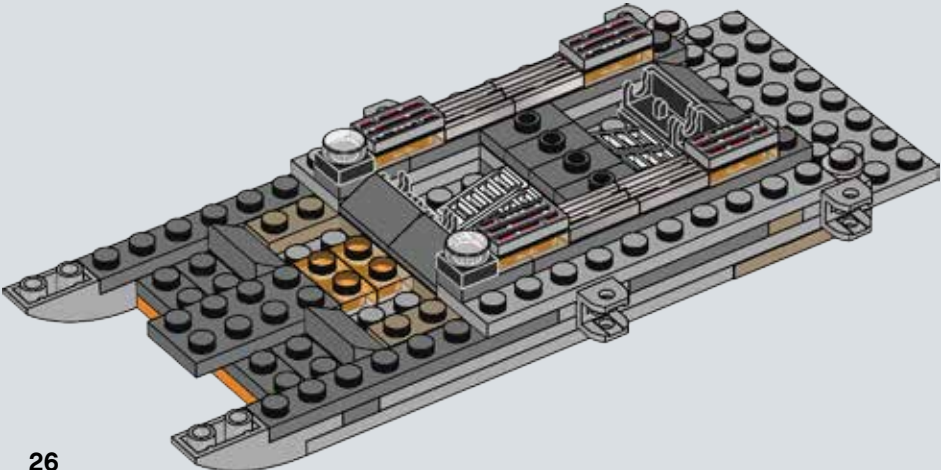

36

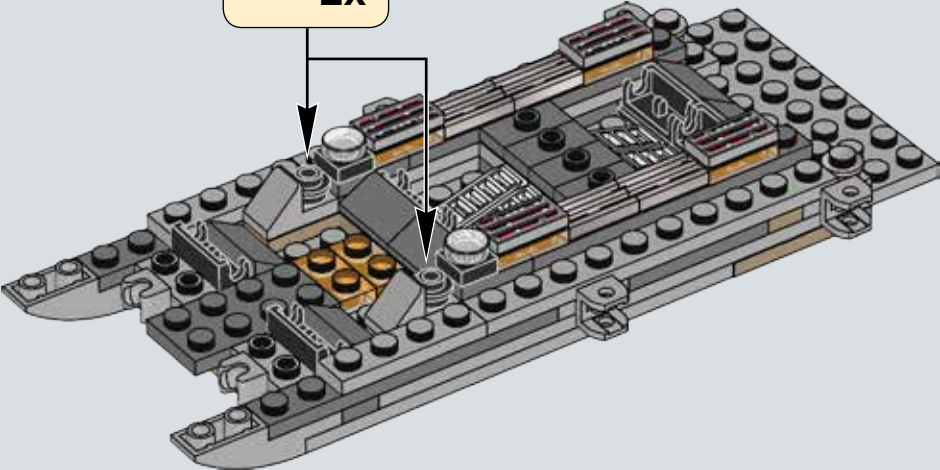
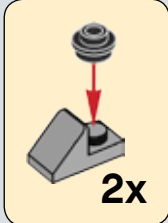

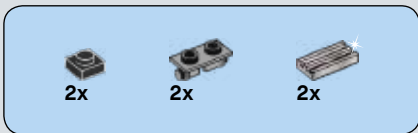

37

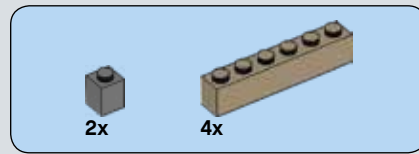
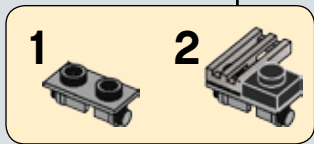
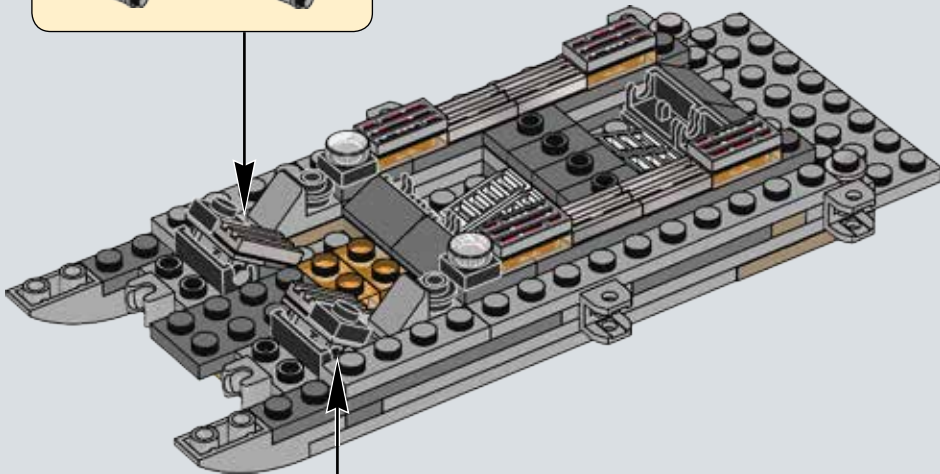
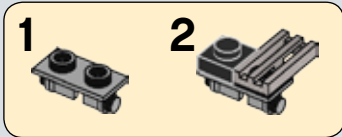

38

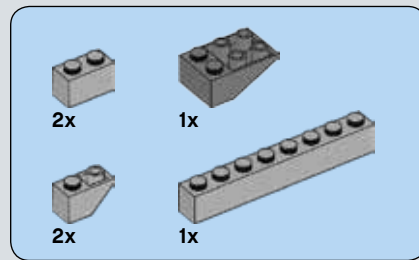
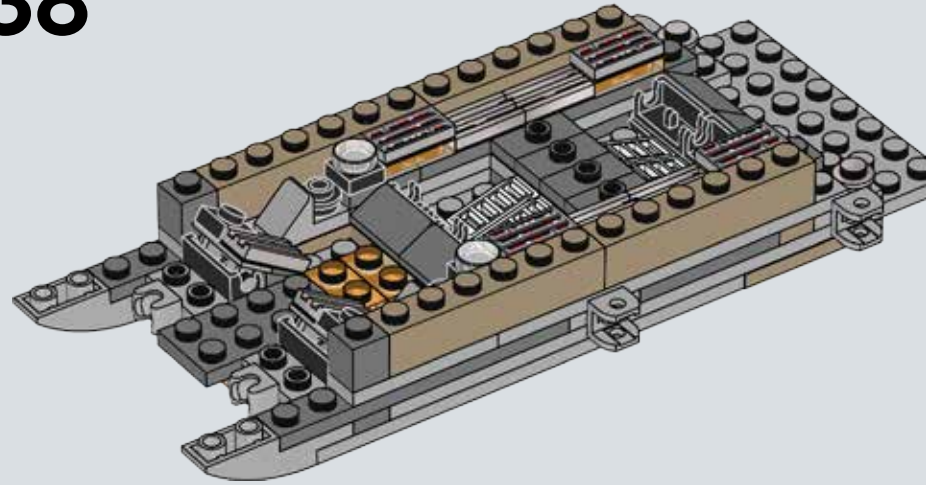

39

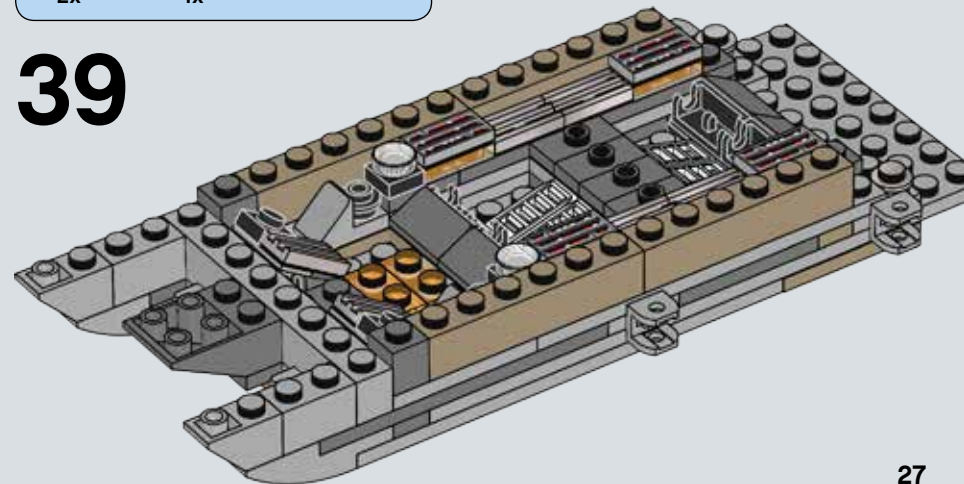

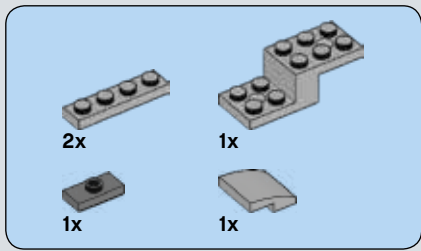

40

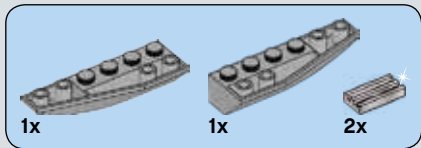
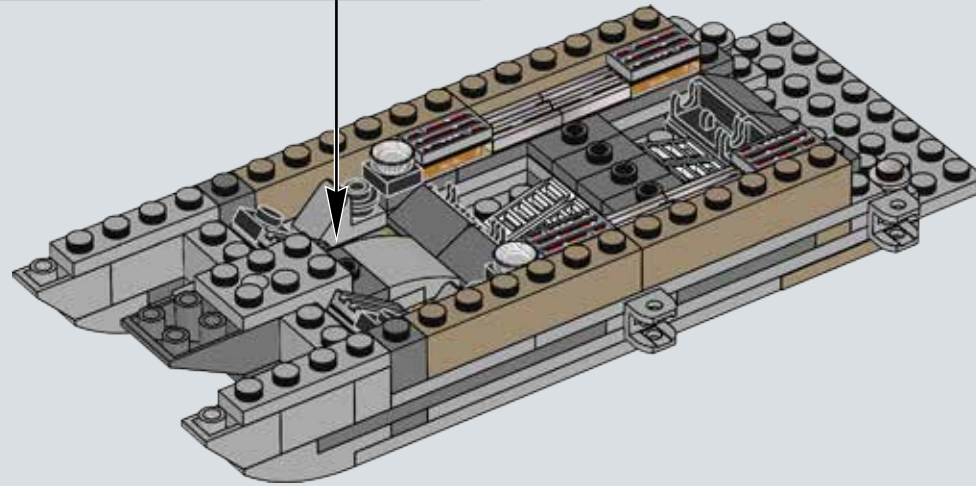
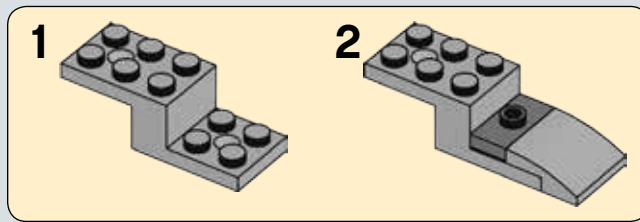

41

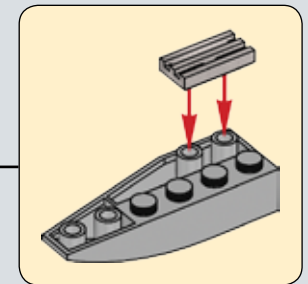
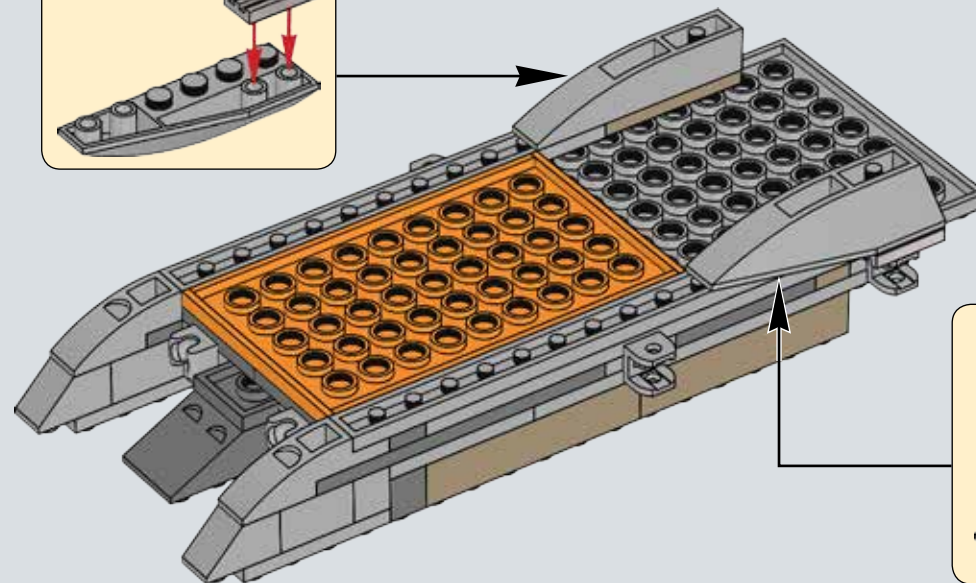
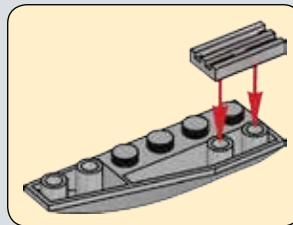
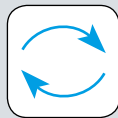

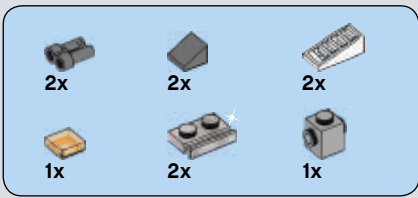

42

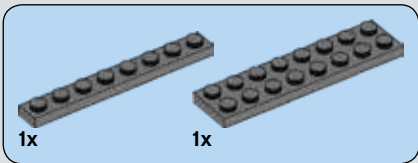
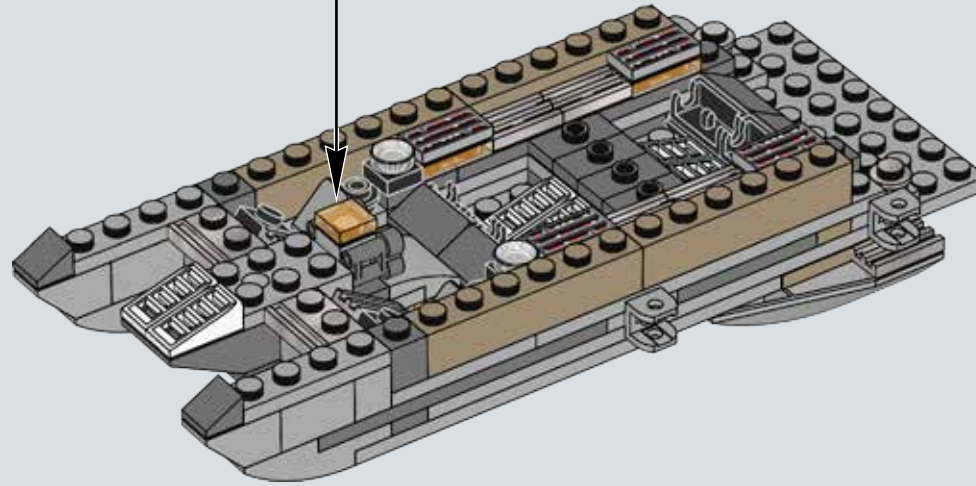
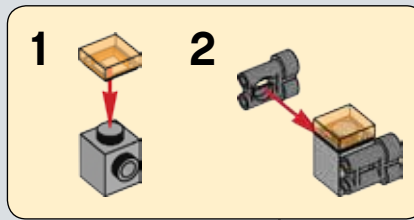
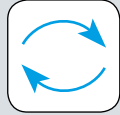

43

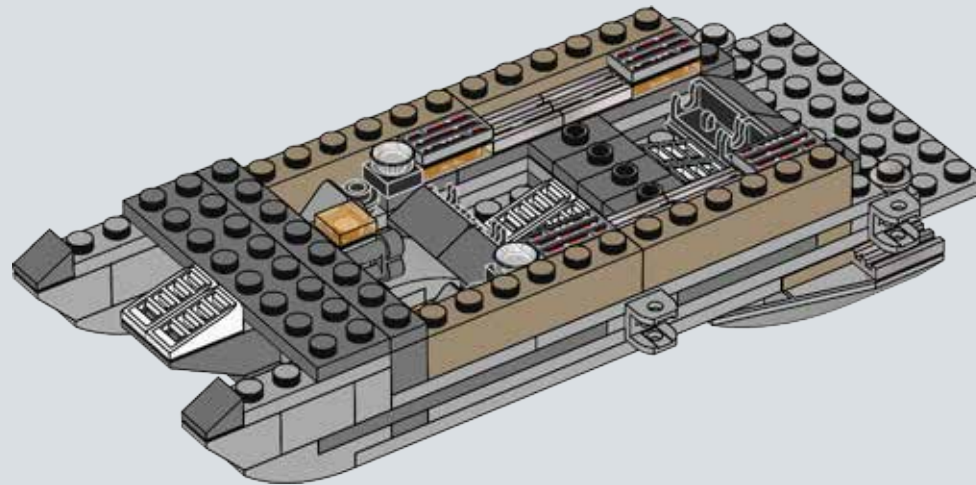

44

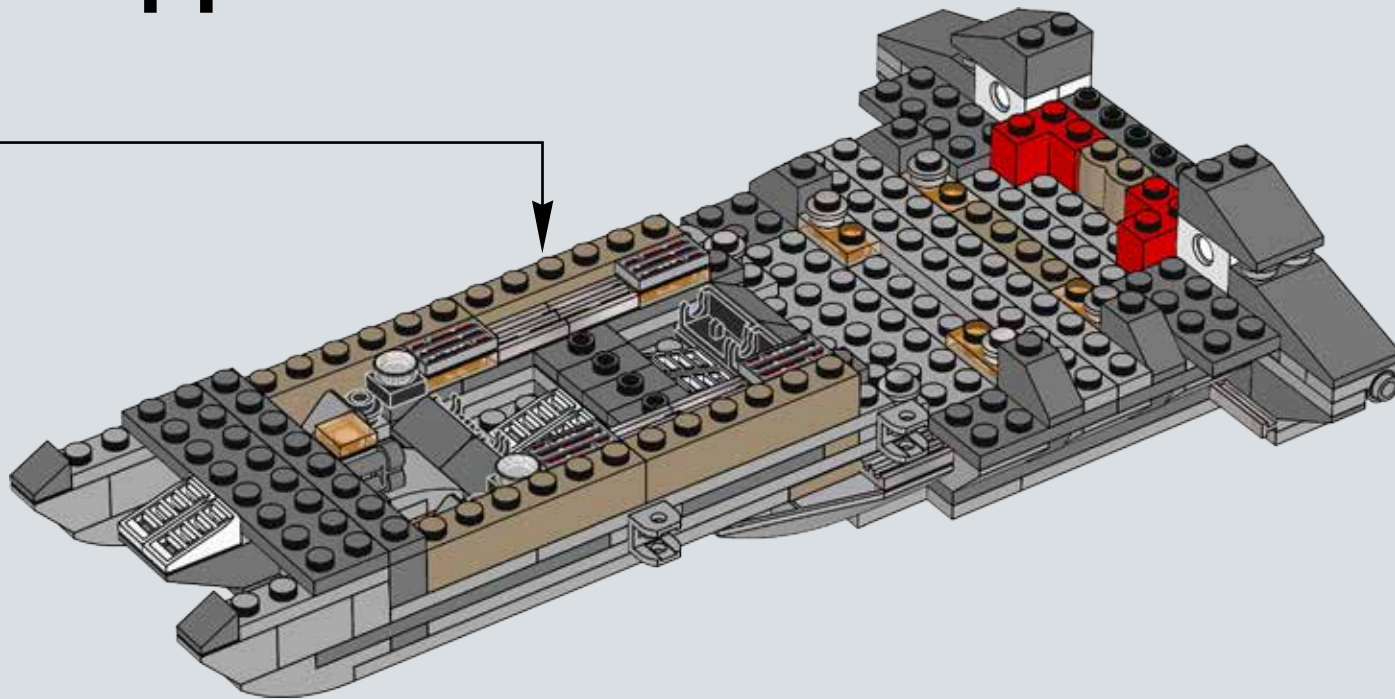

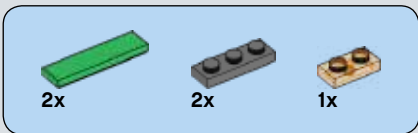

45

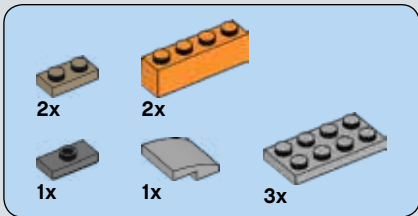
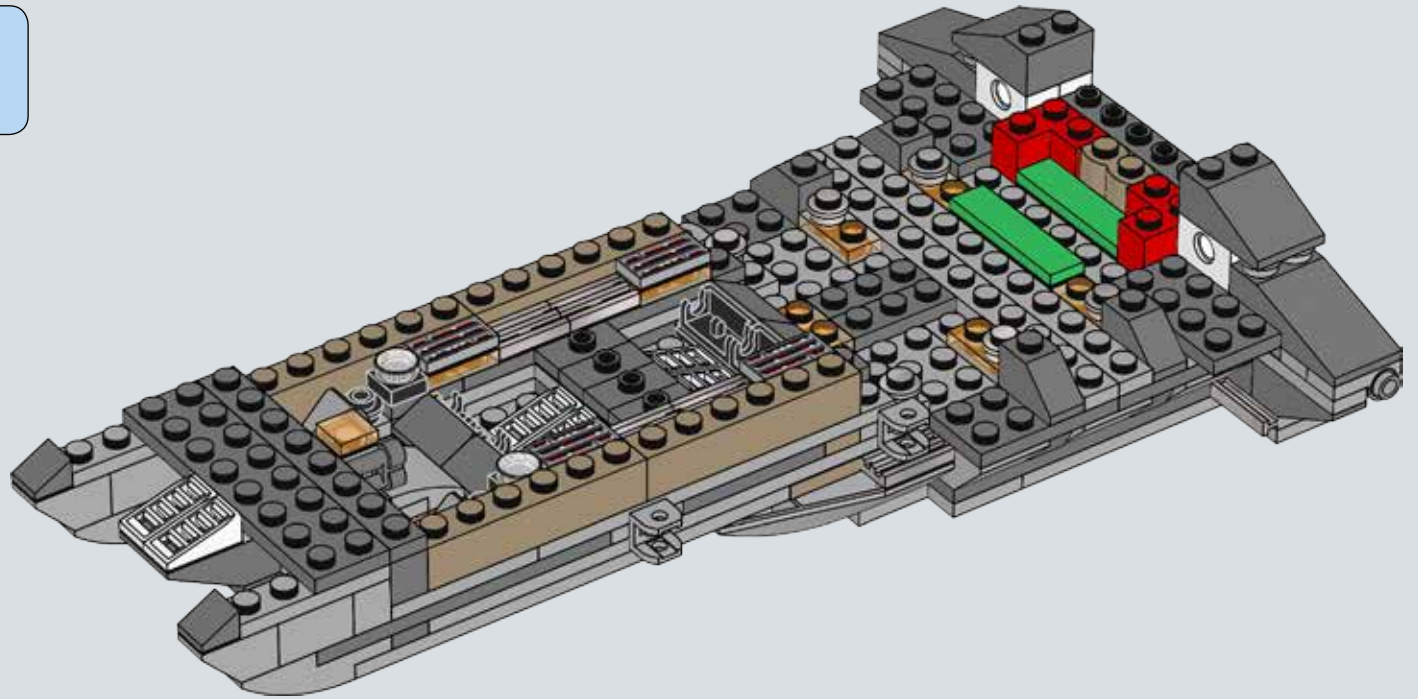

46

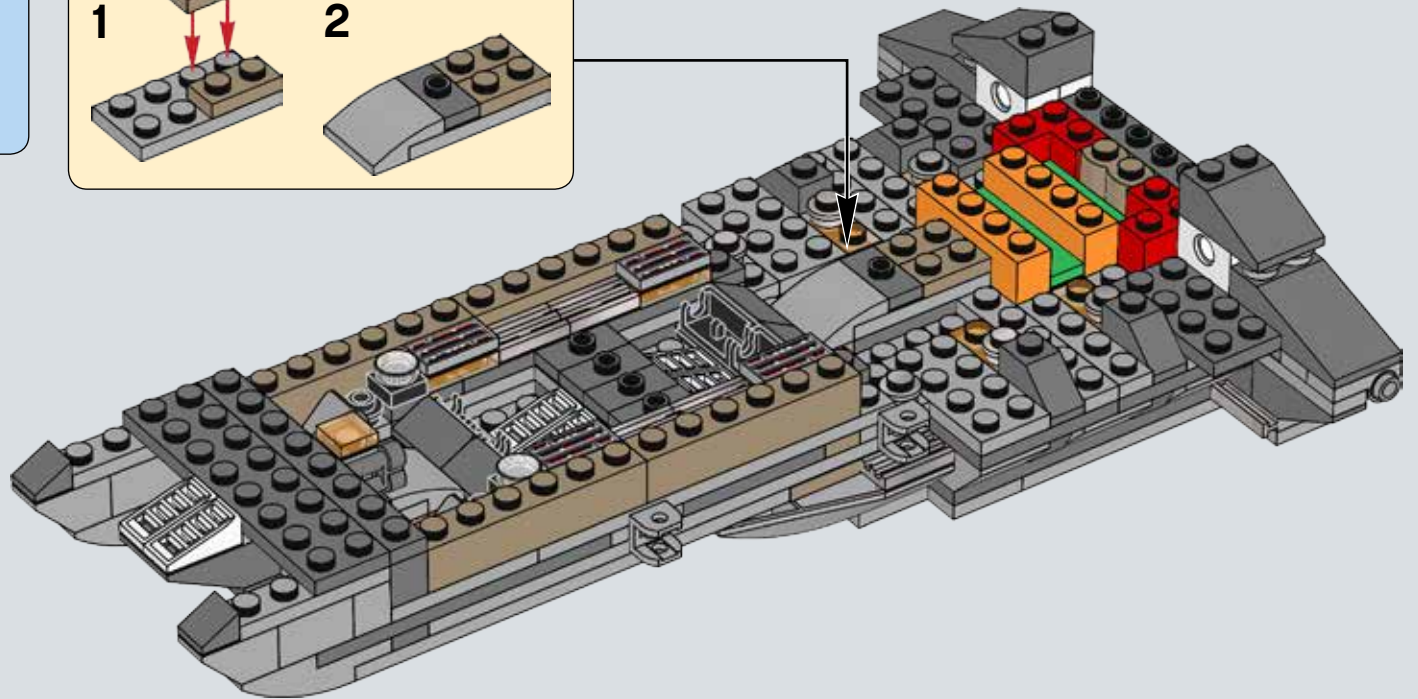
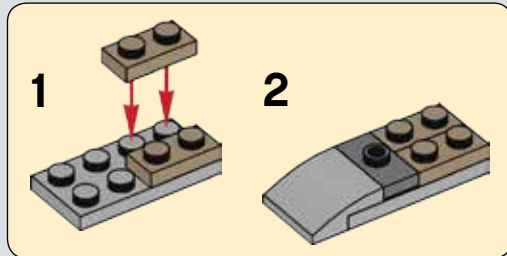

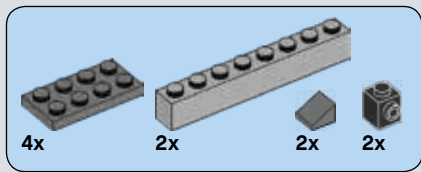

47

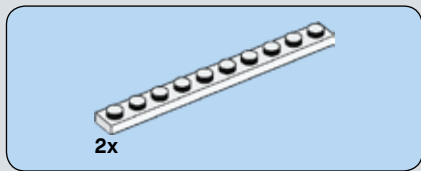
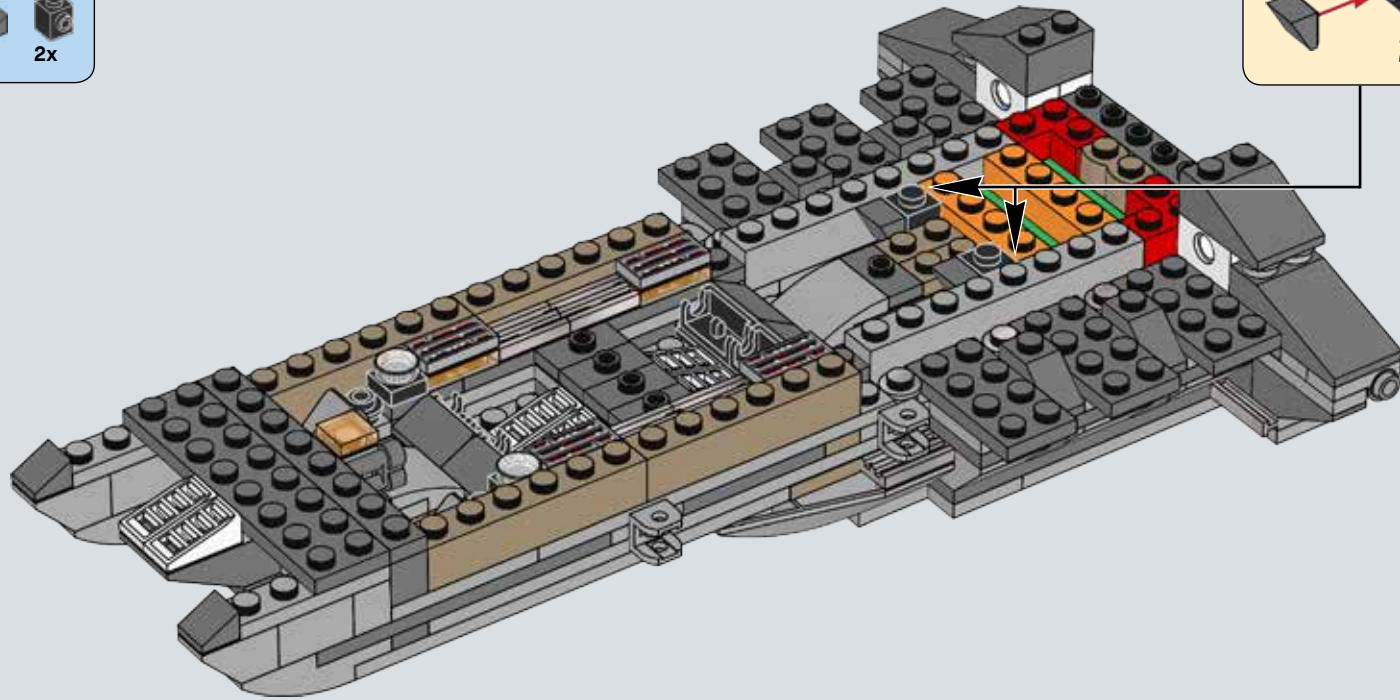

48

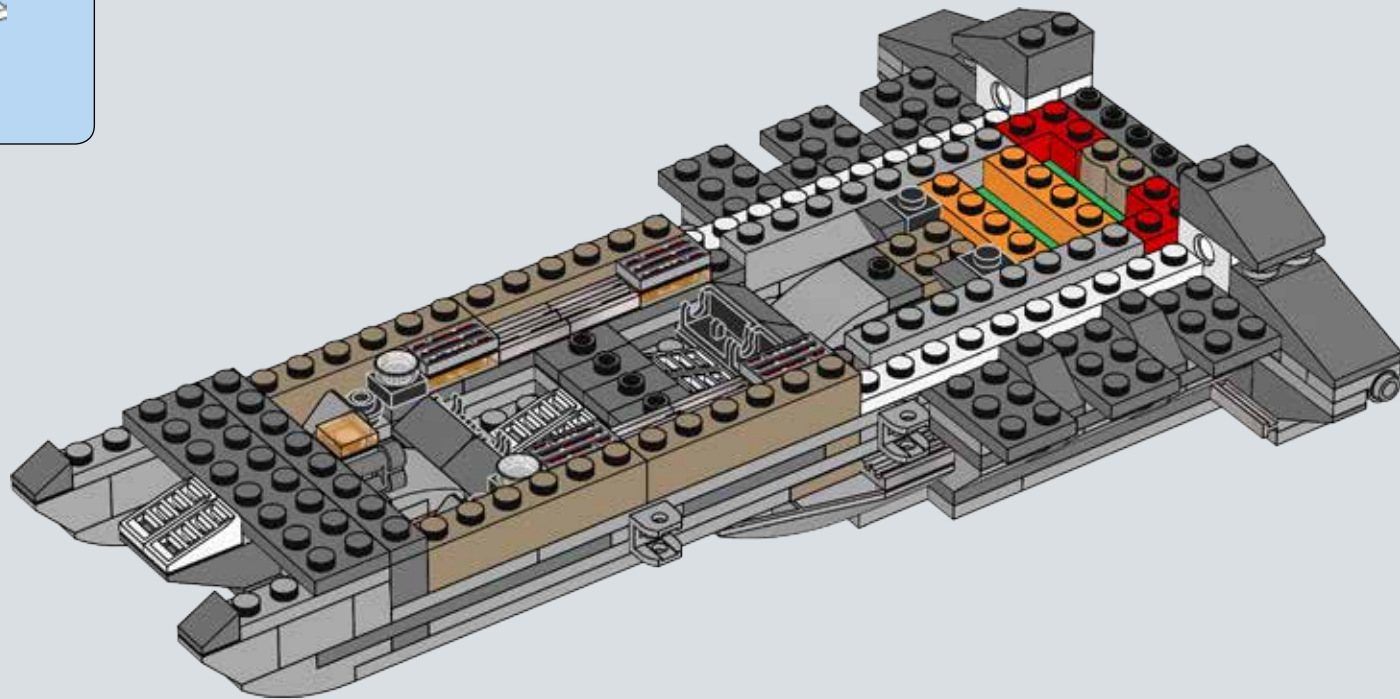



49

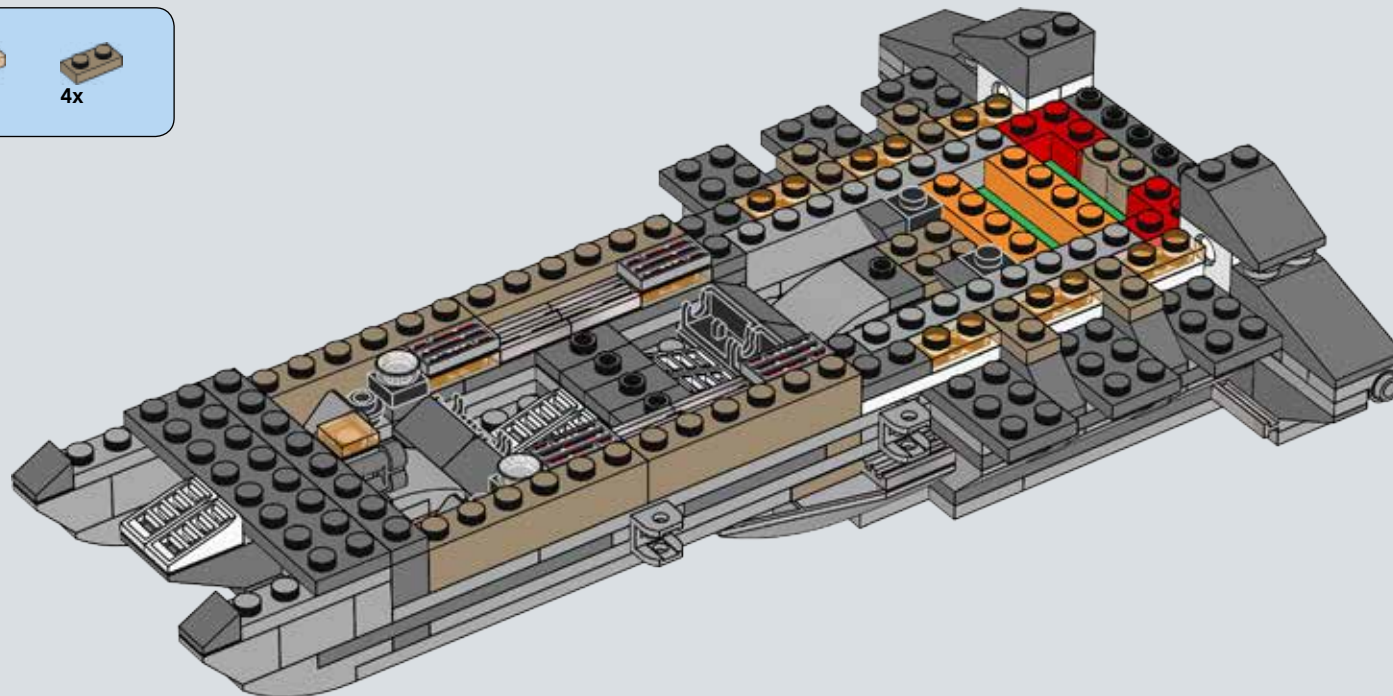

50

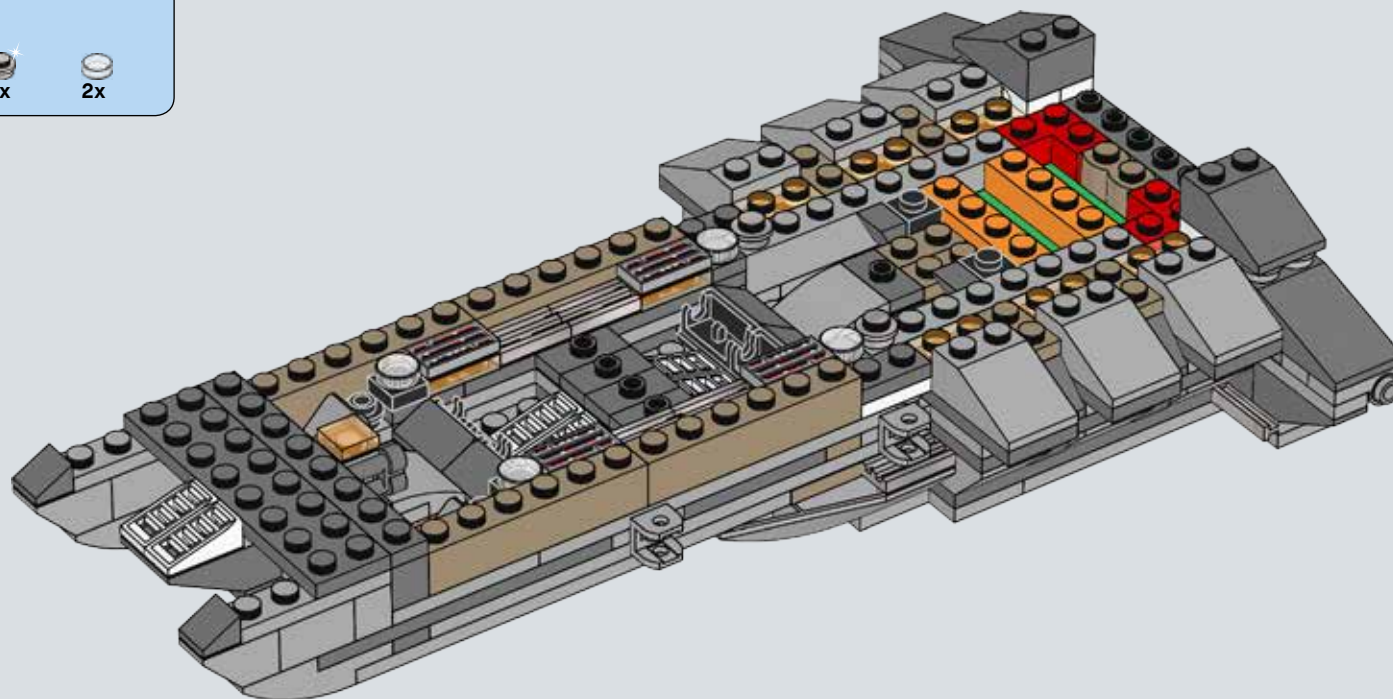

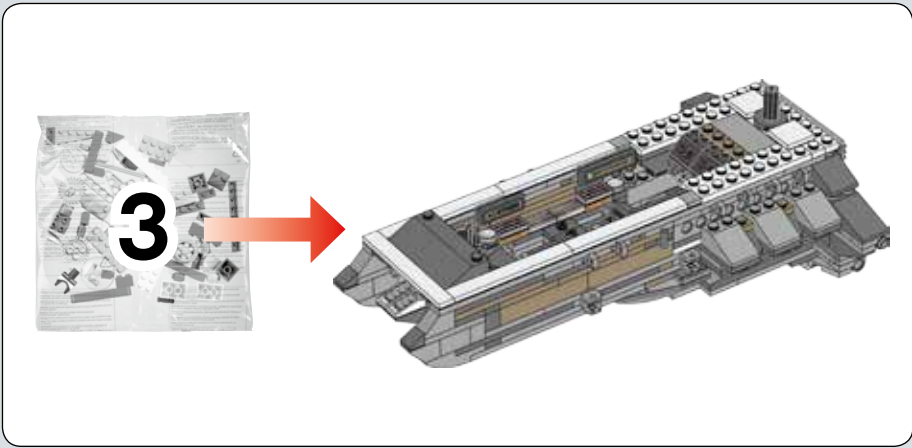

51

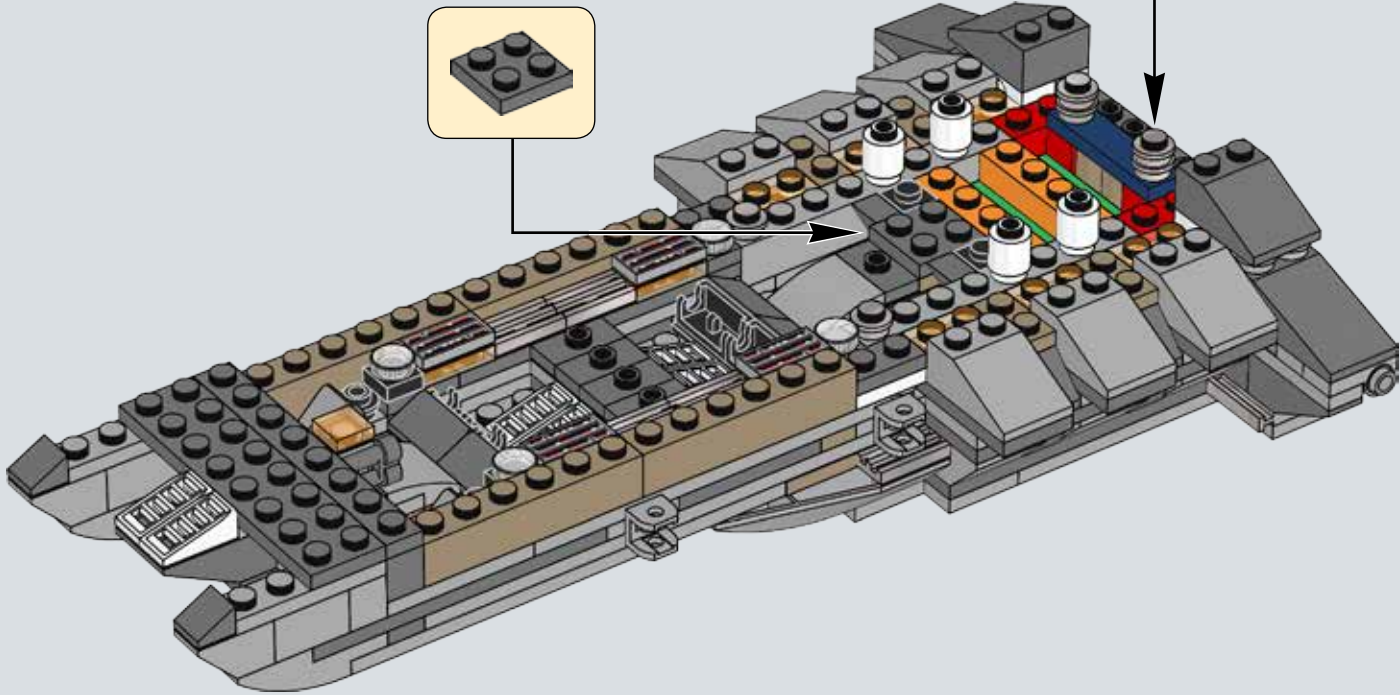
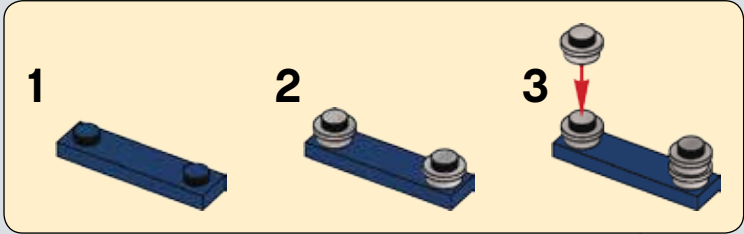

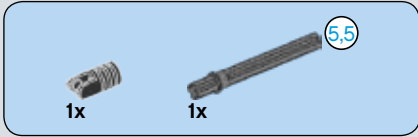
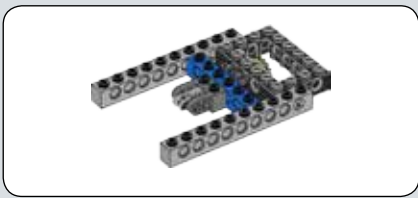

52

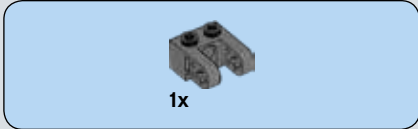
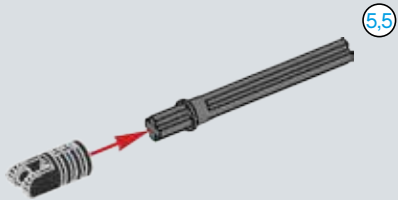

53

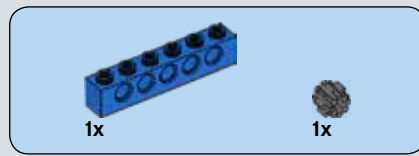
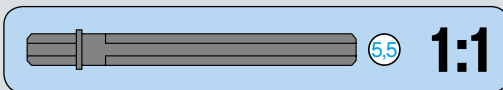
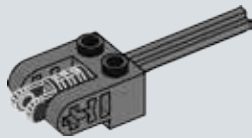

54

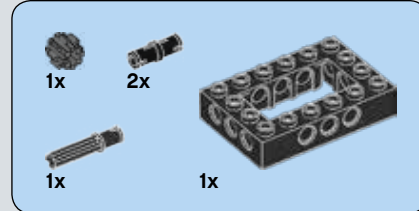
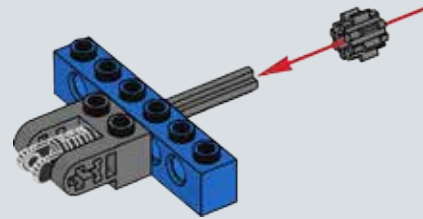

55

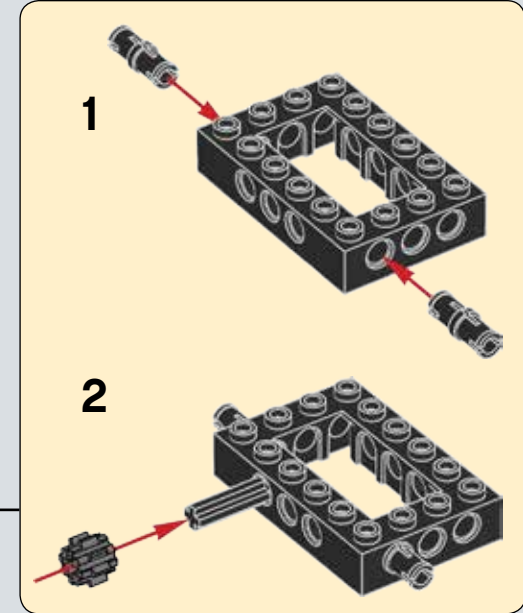
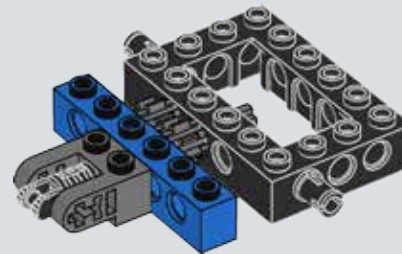



1x

56

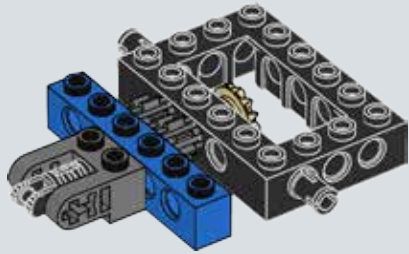

2x

57

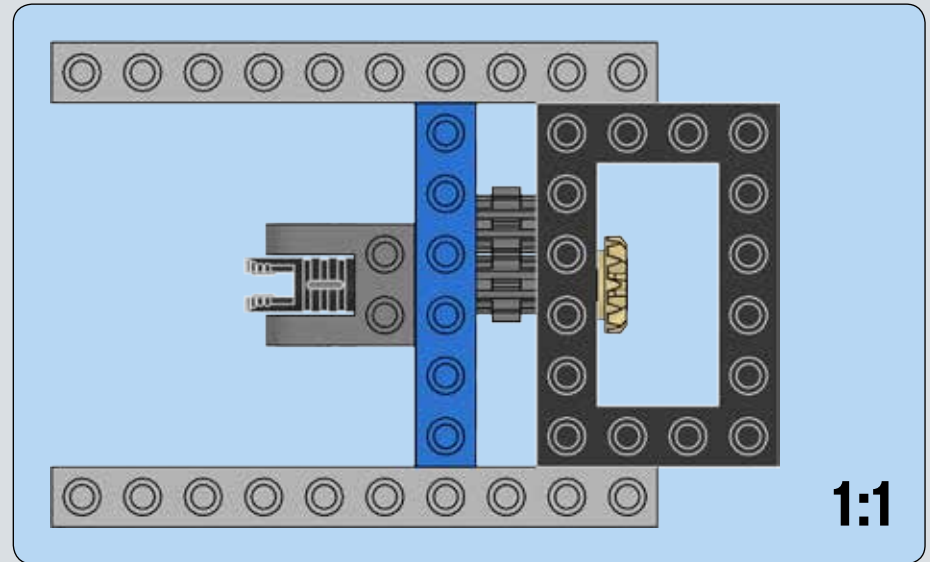
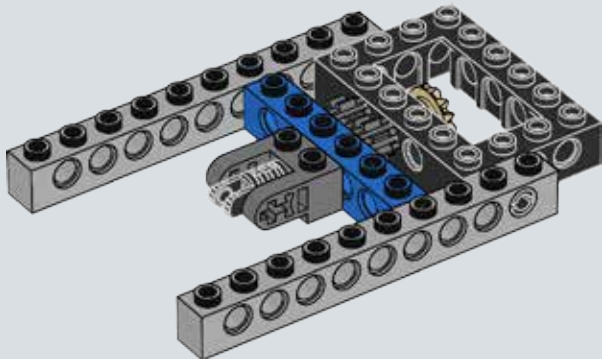

58

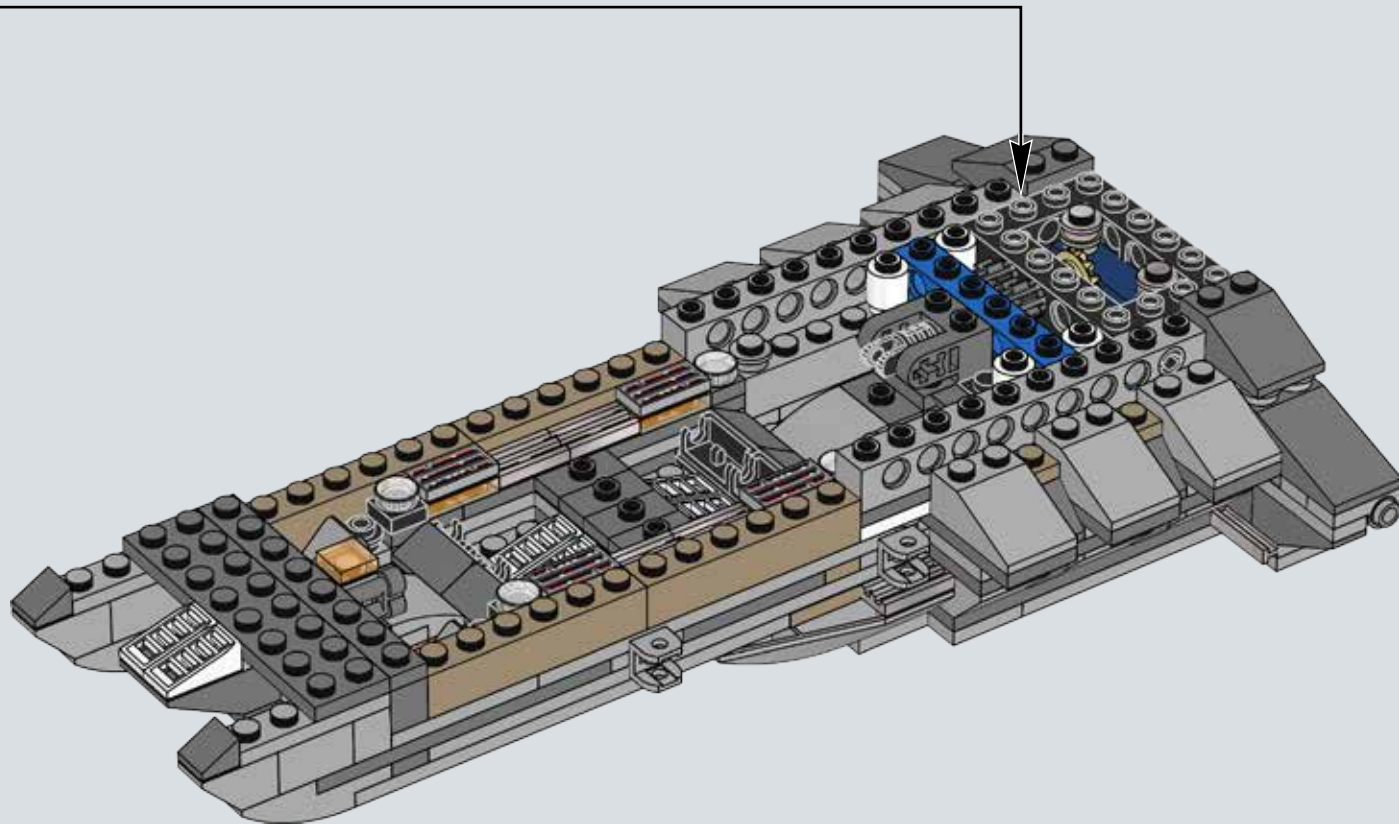



2x

59

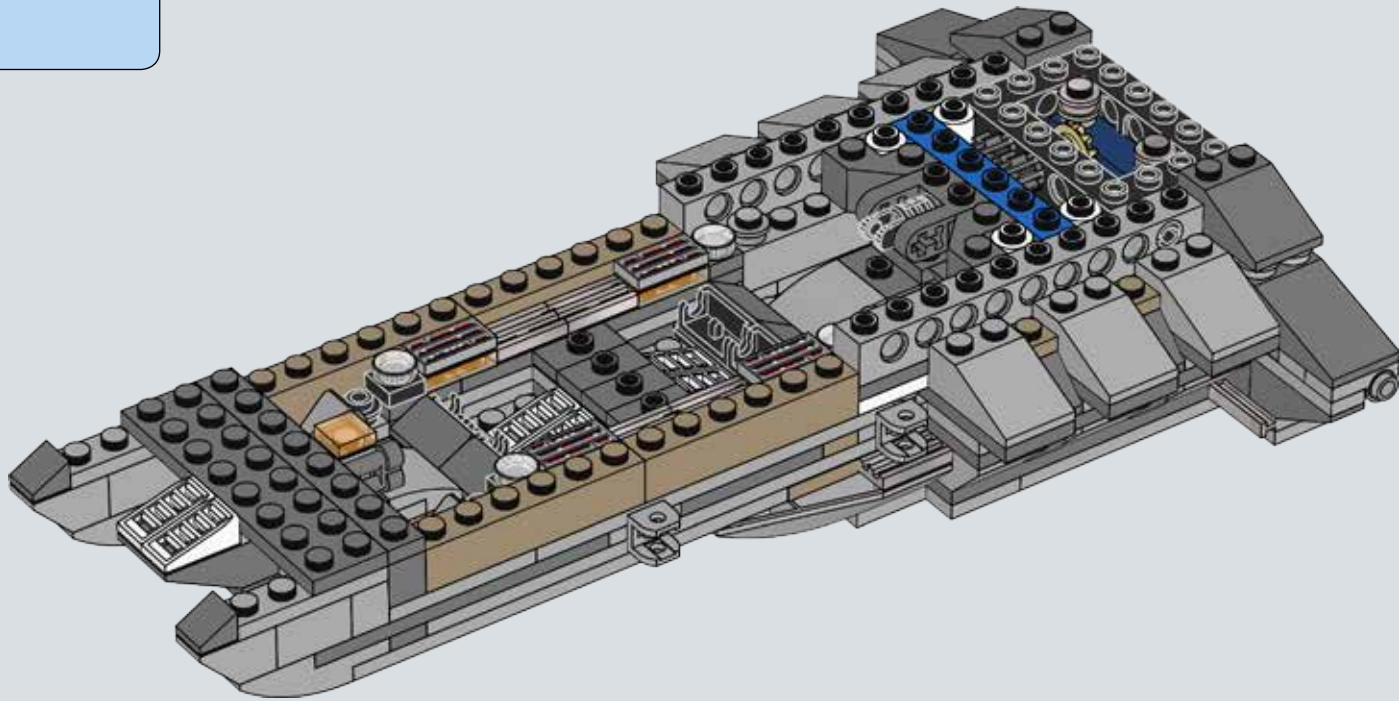

1x



2x

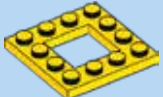

1x

60

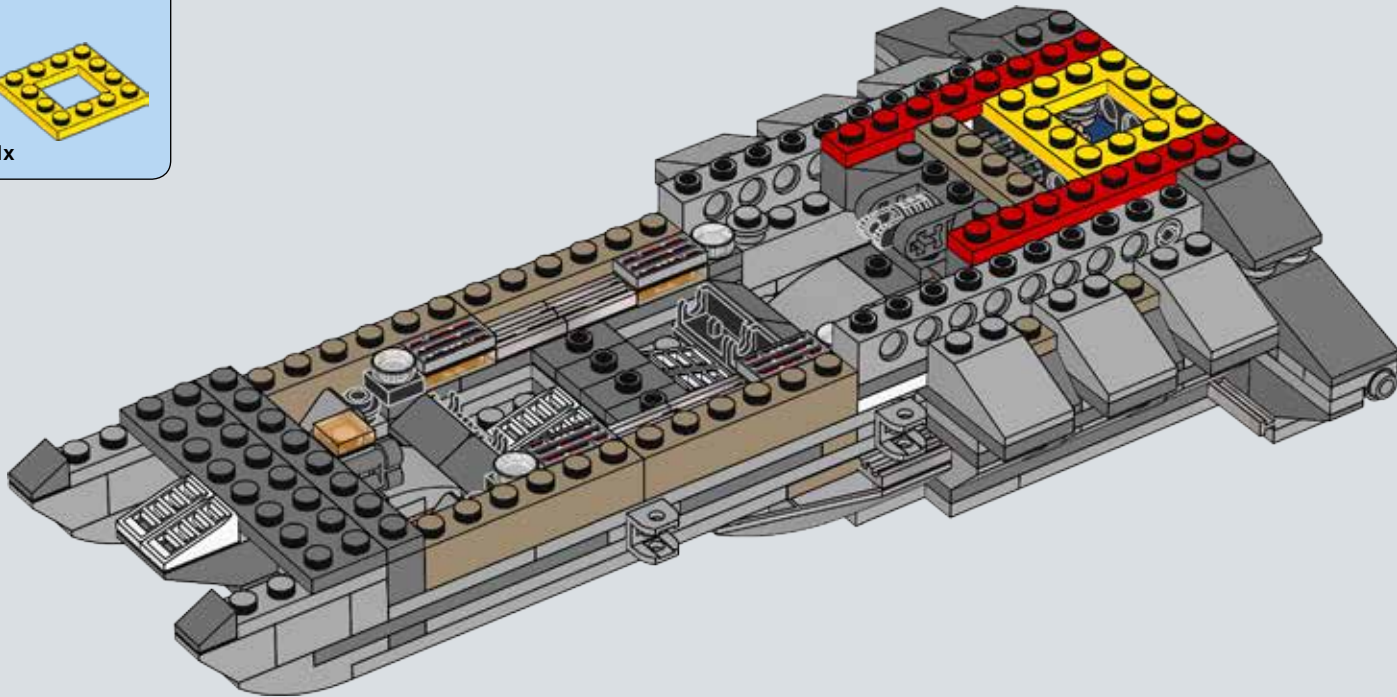

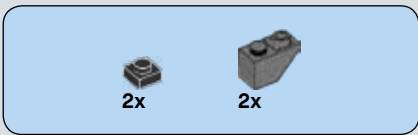

61

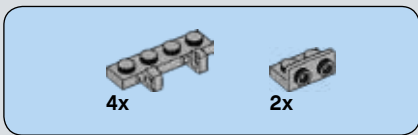
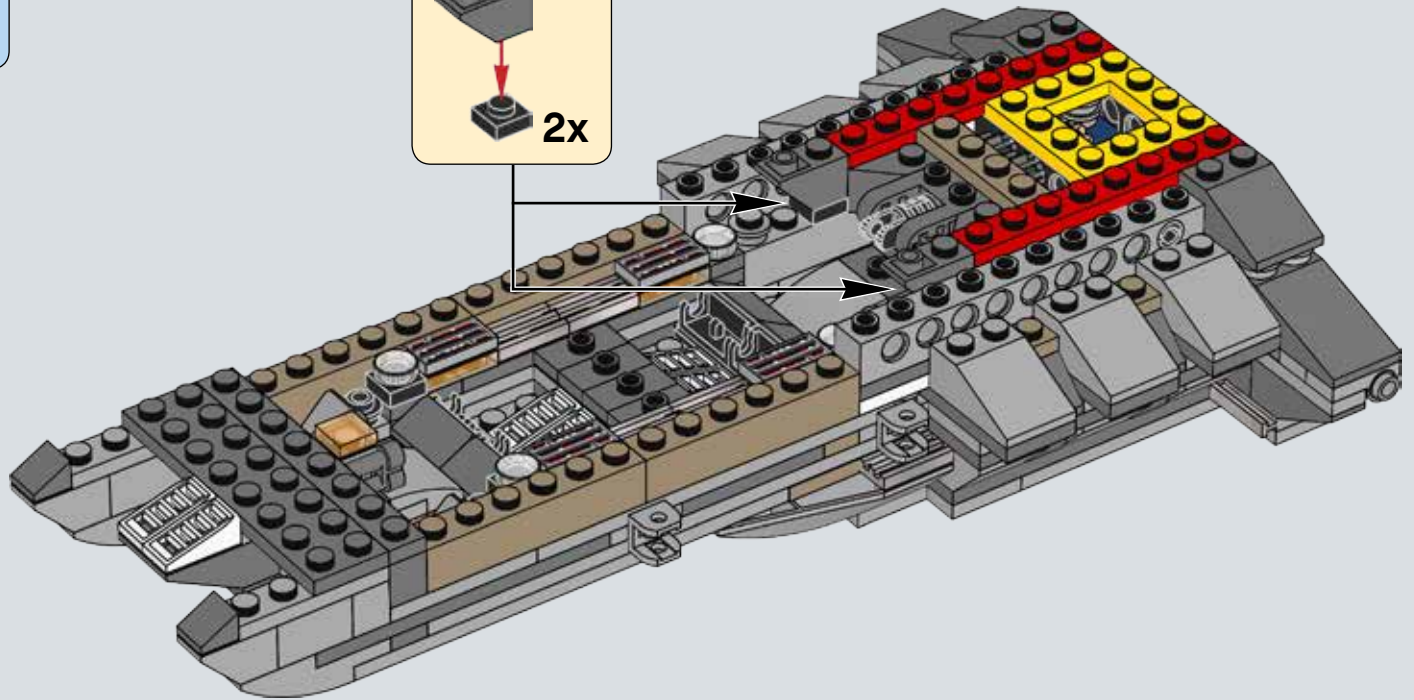
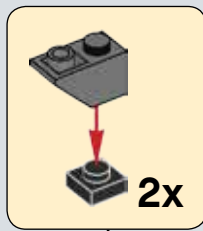

62

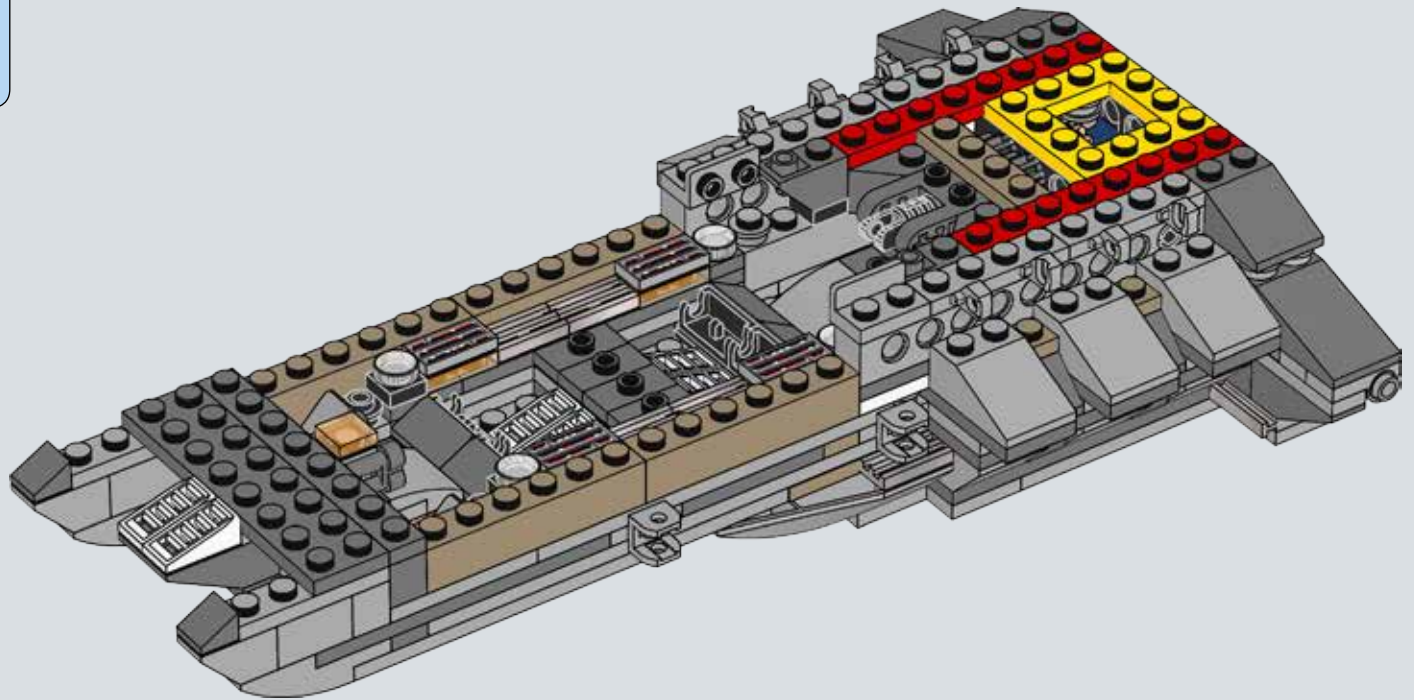

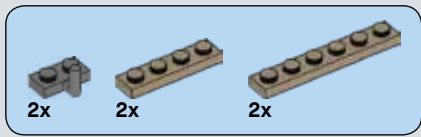

63

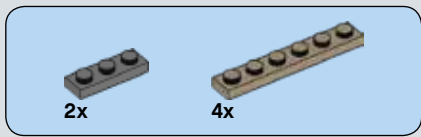
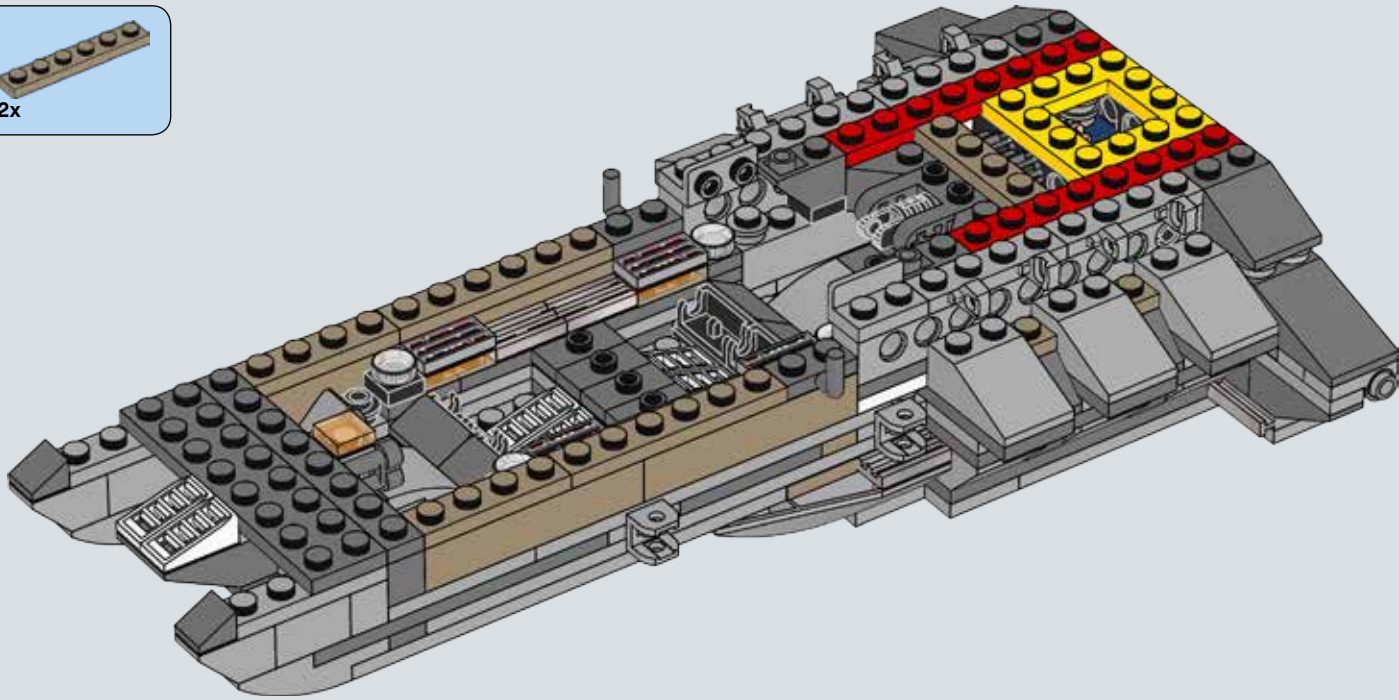

64

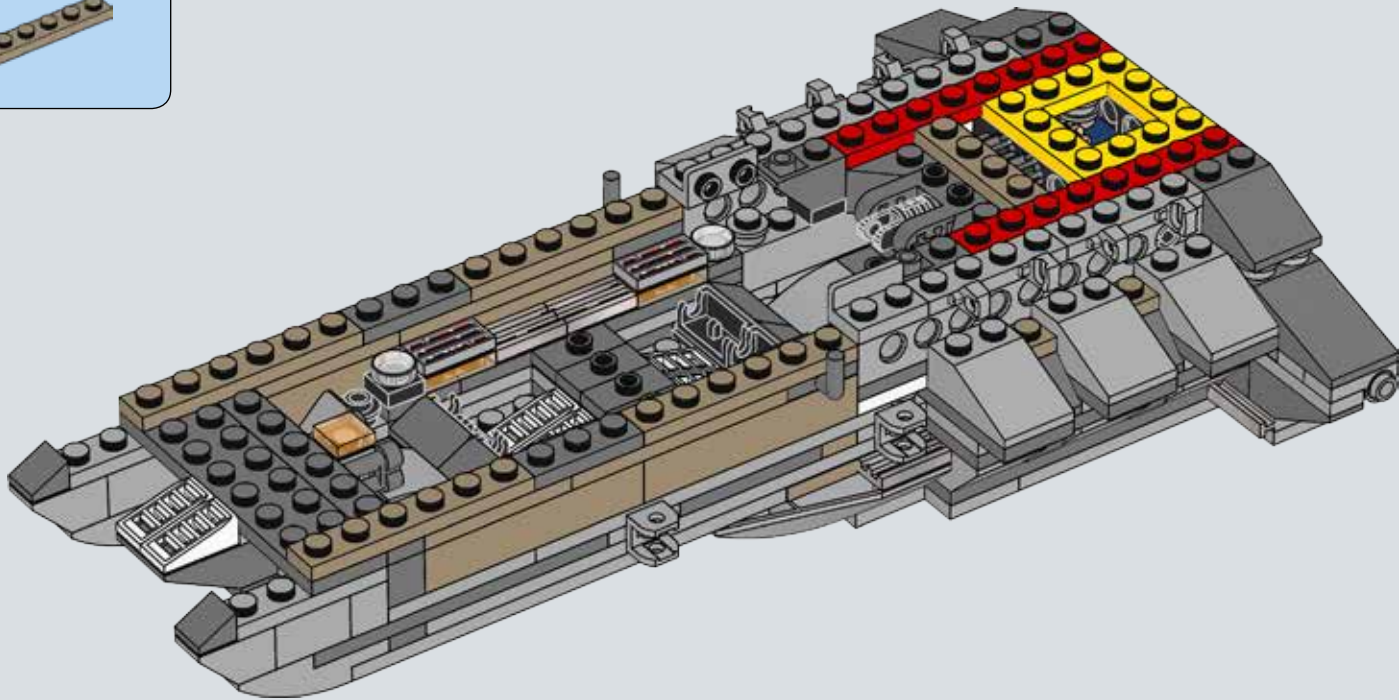

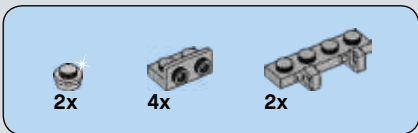

65

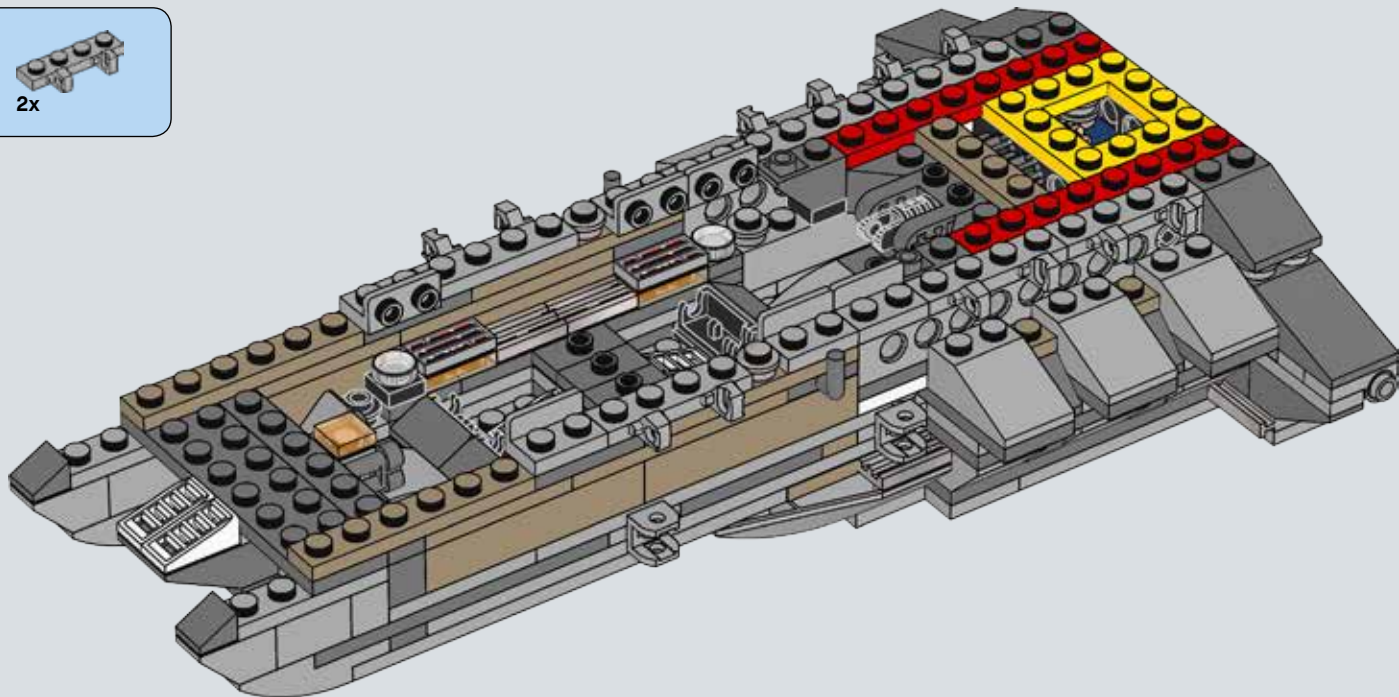

66

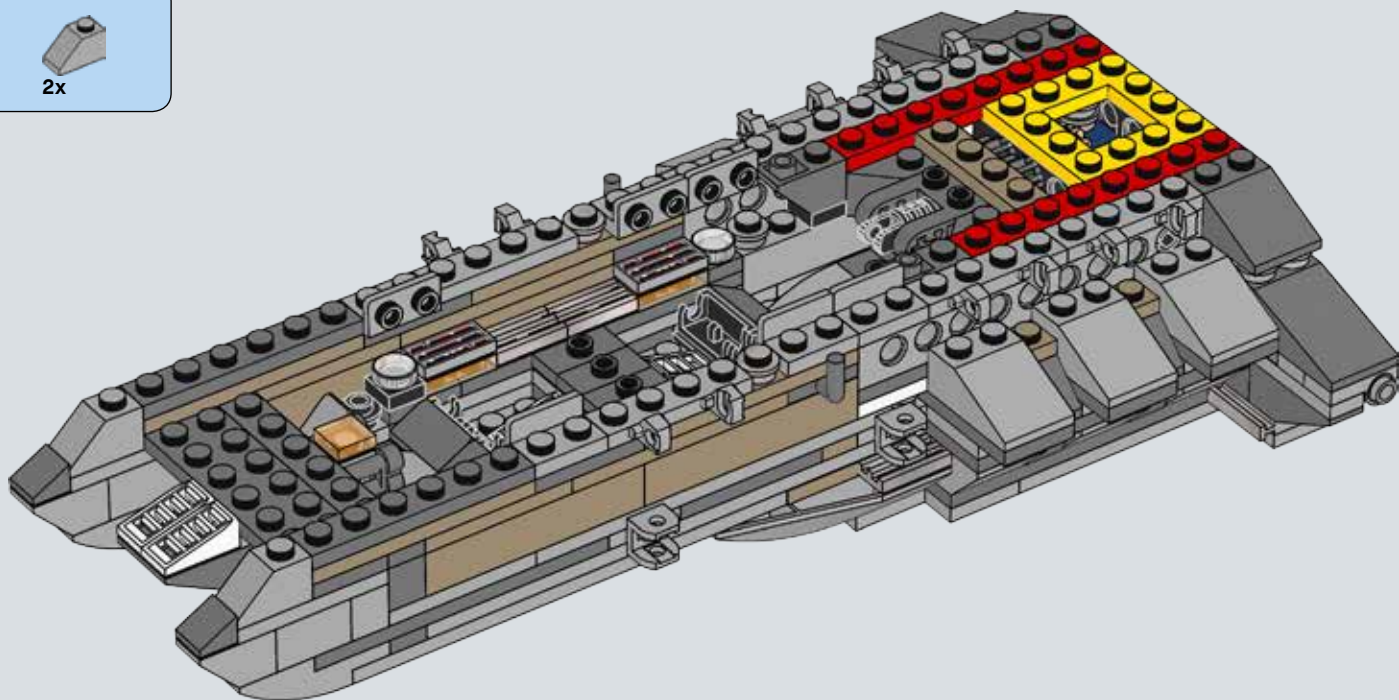



67

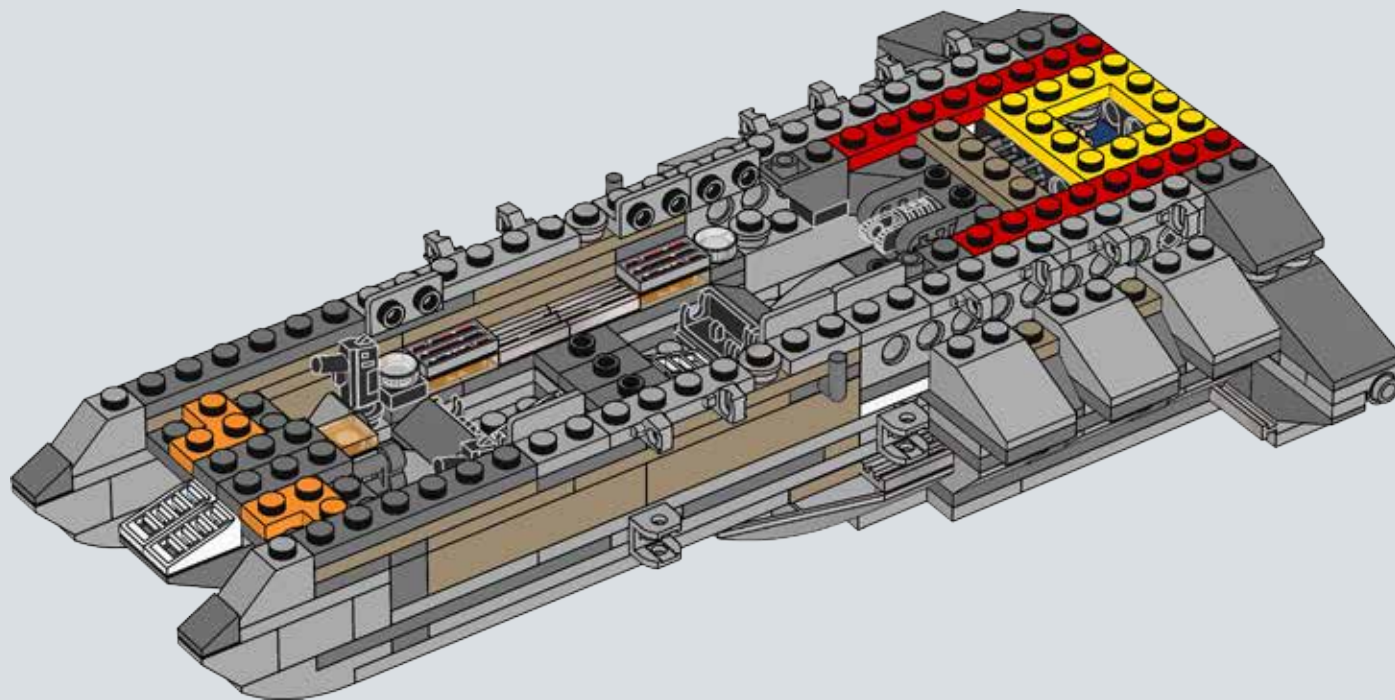

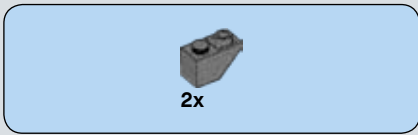

68

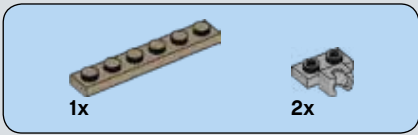
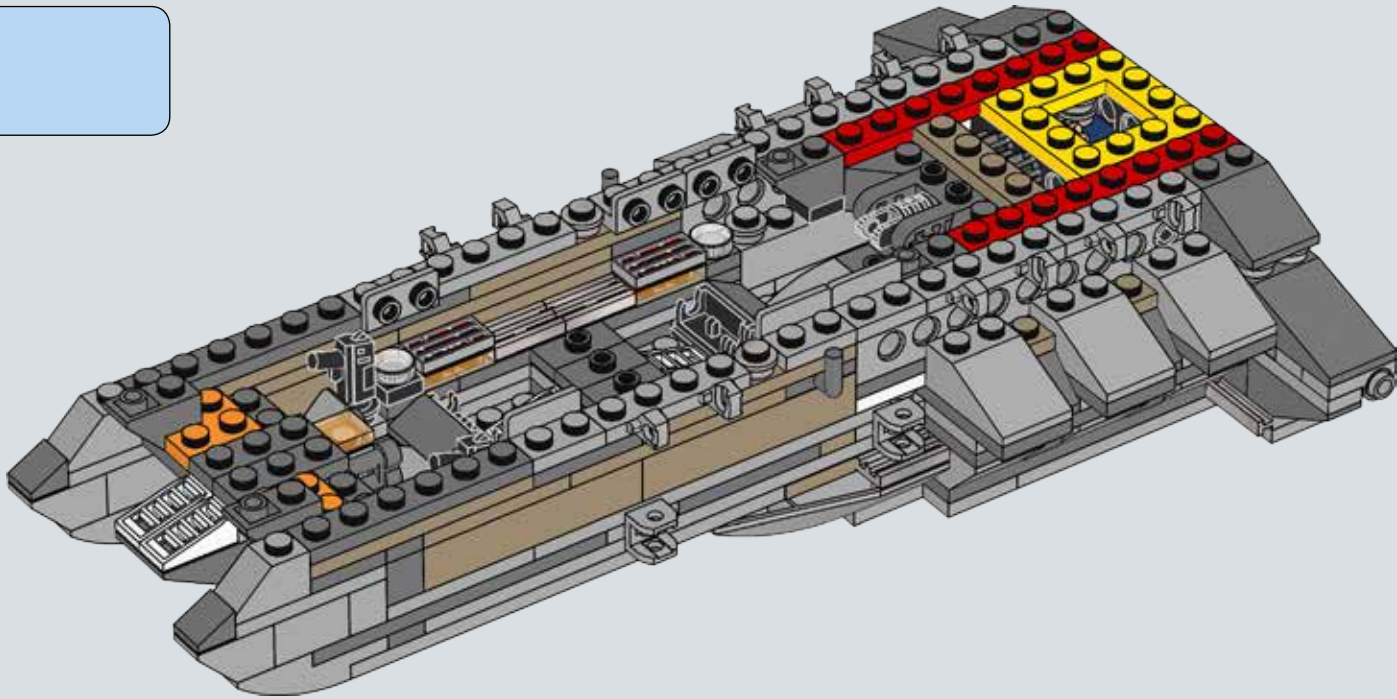

69

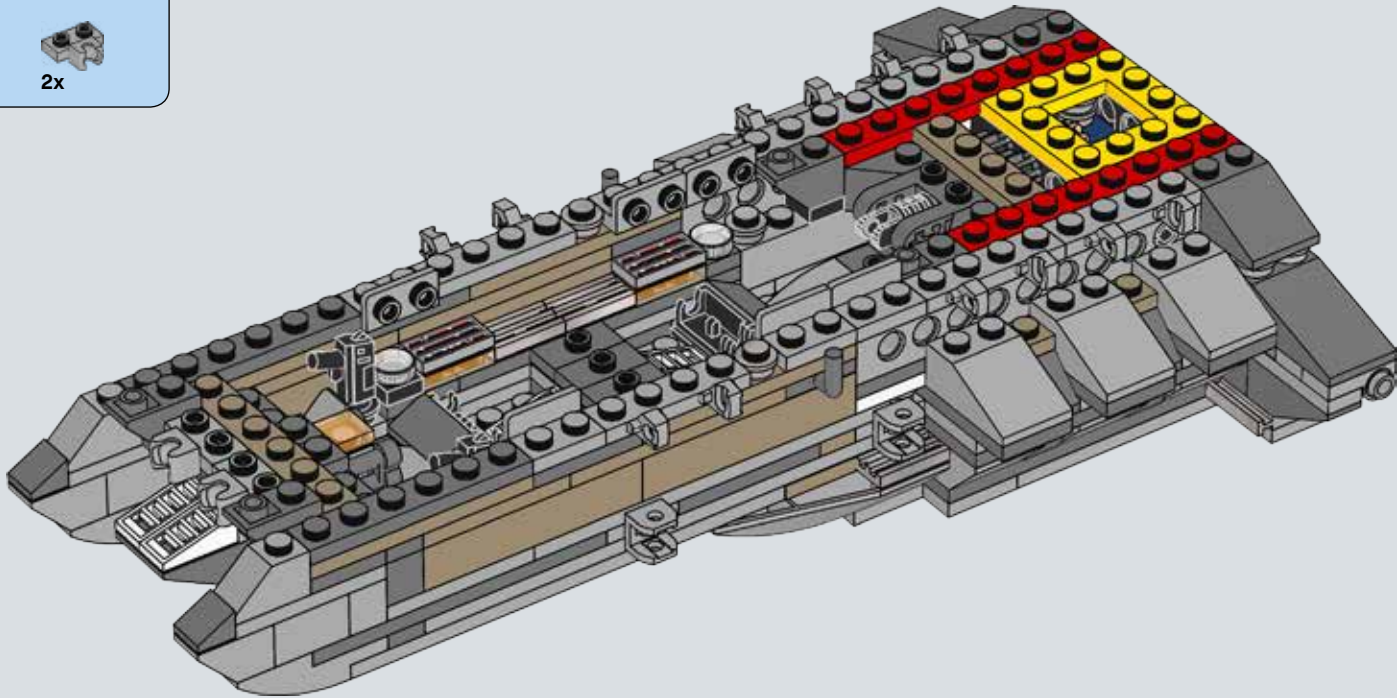

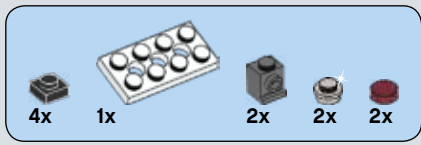

70

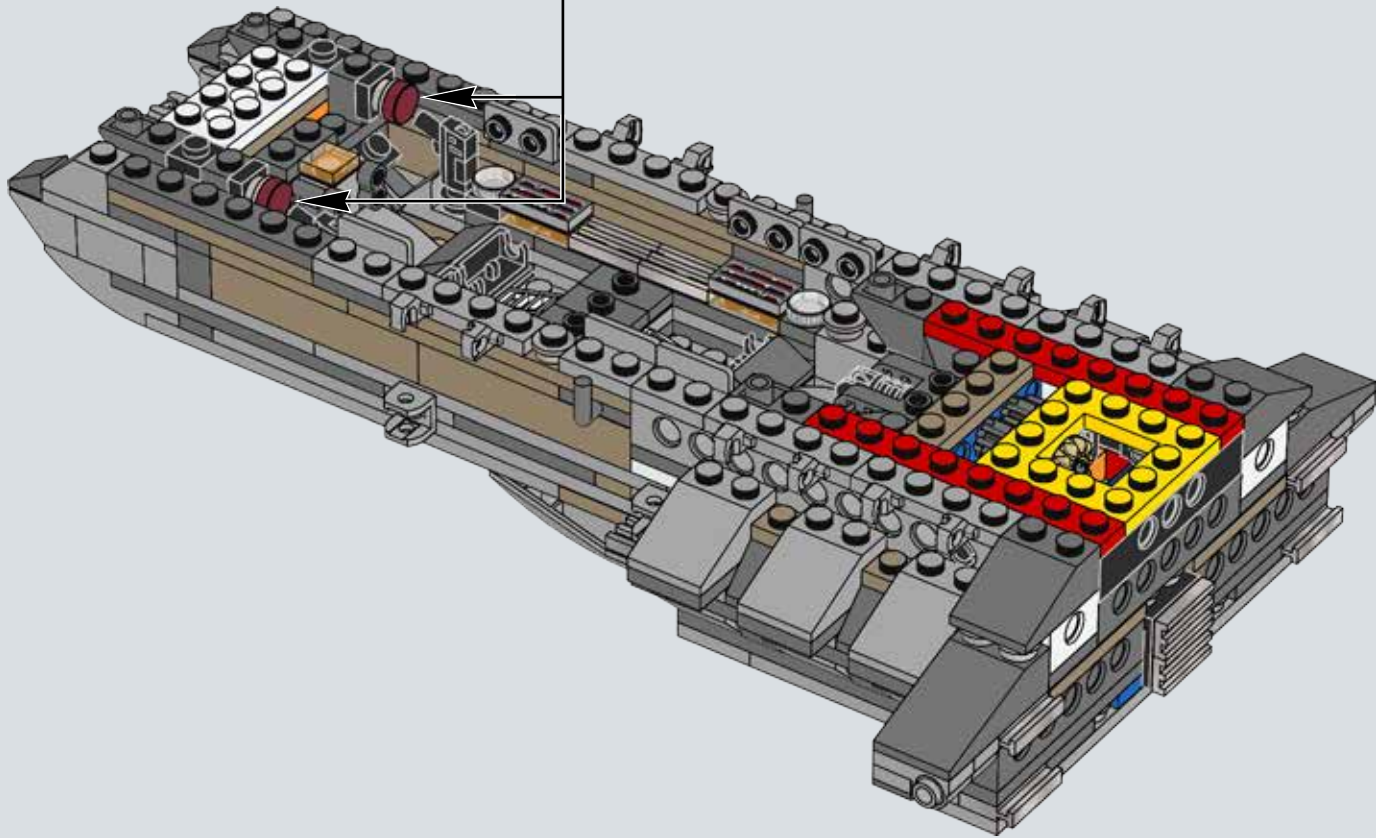
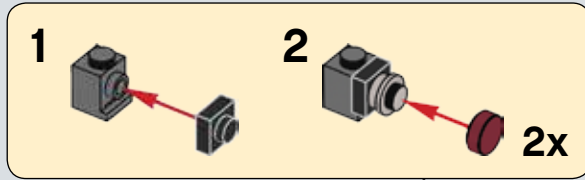



71

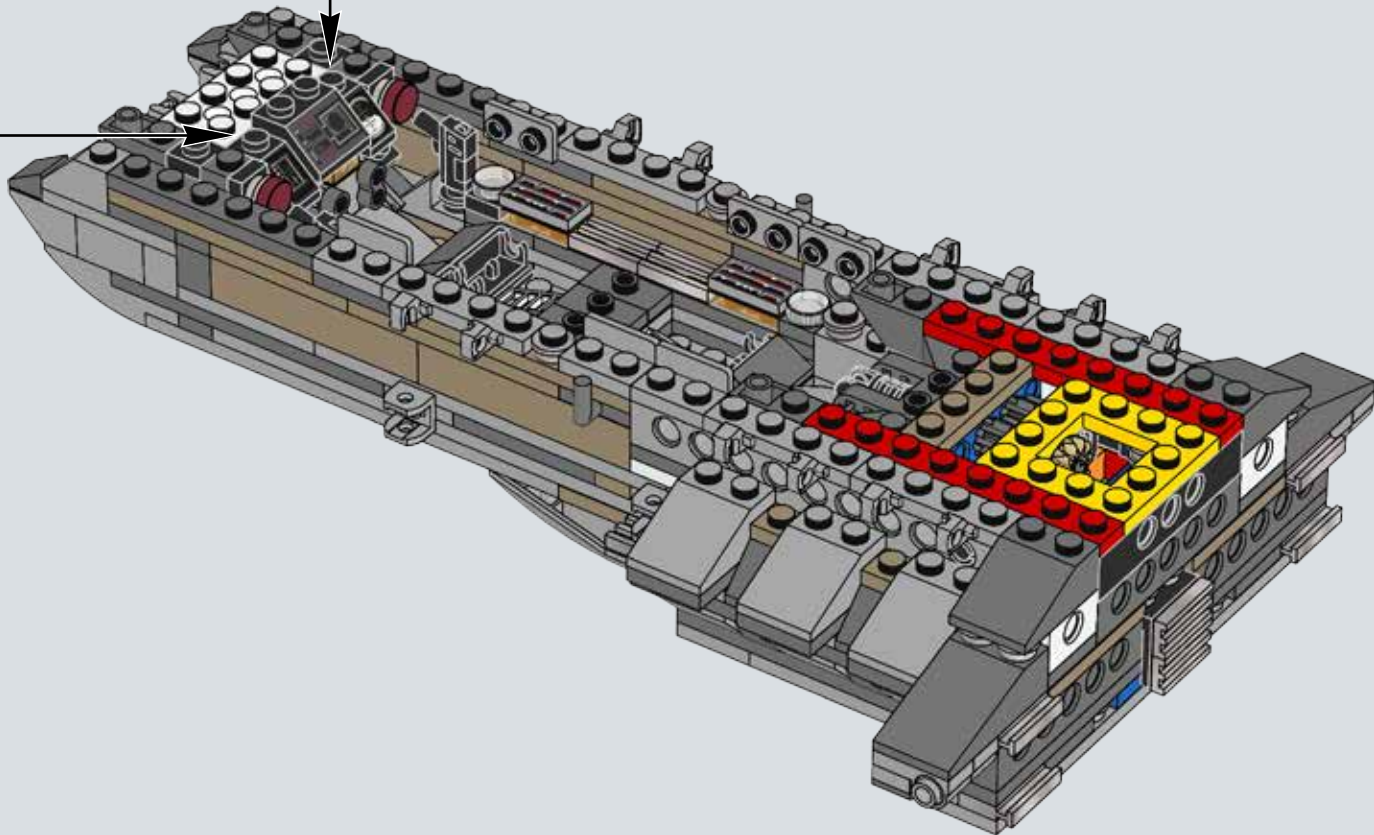
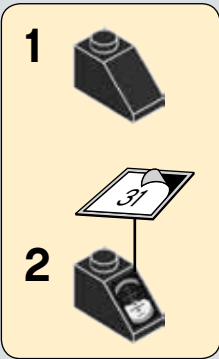
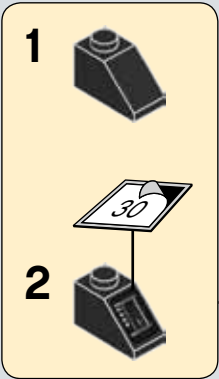



3x

72

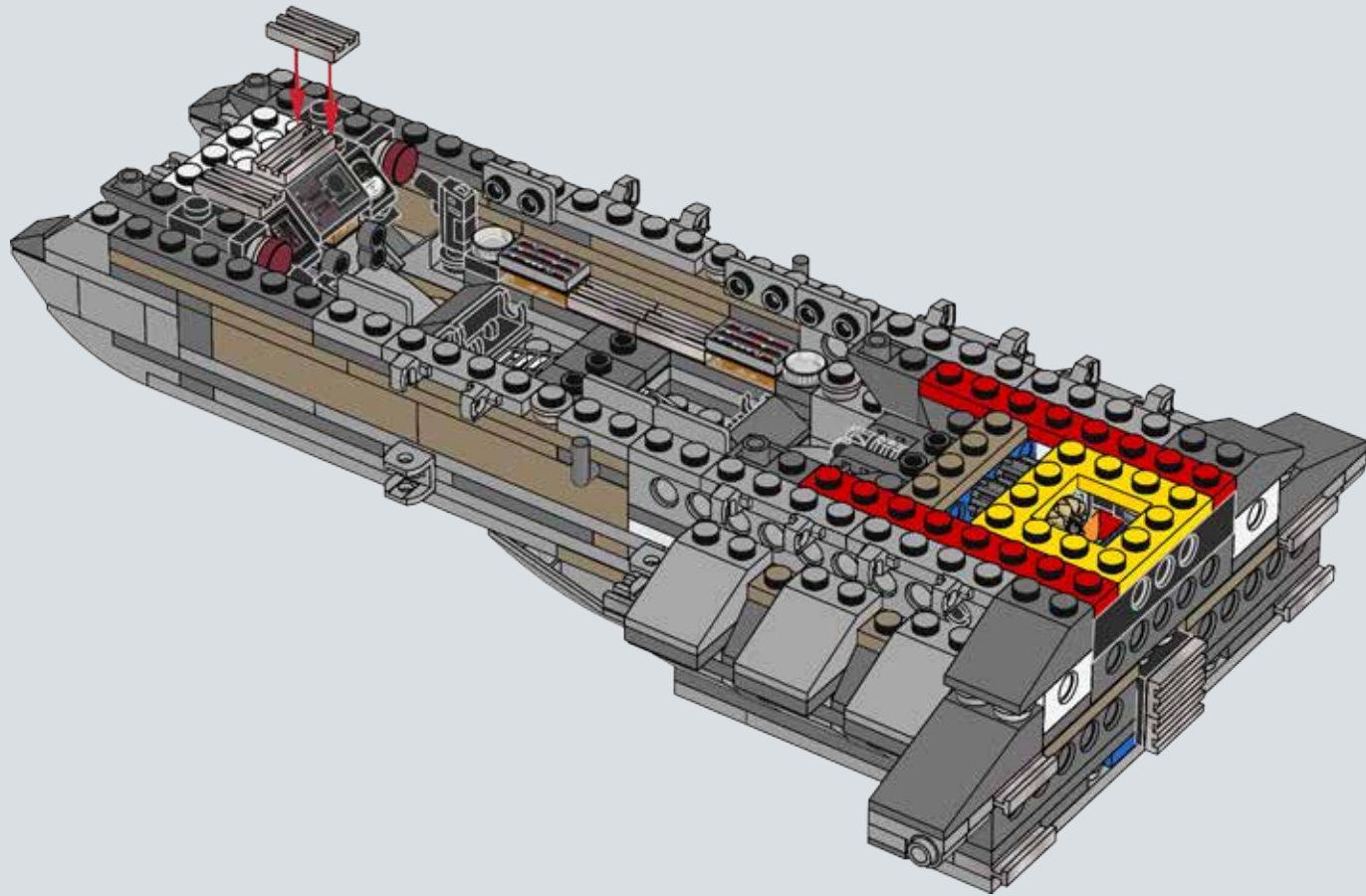



73

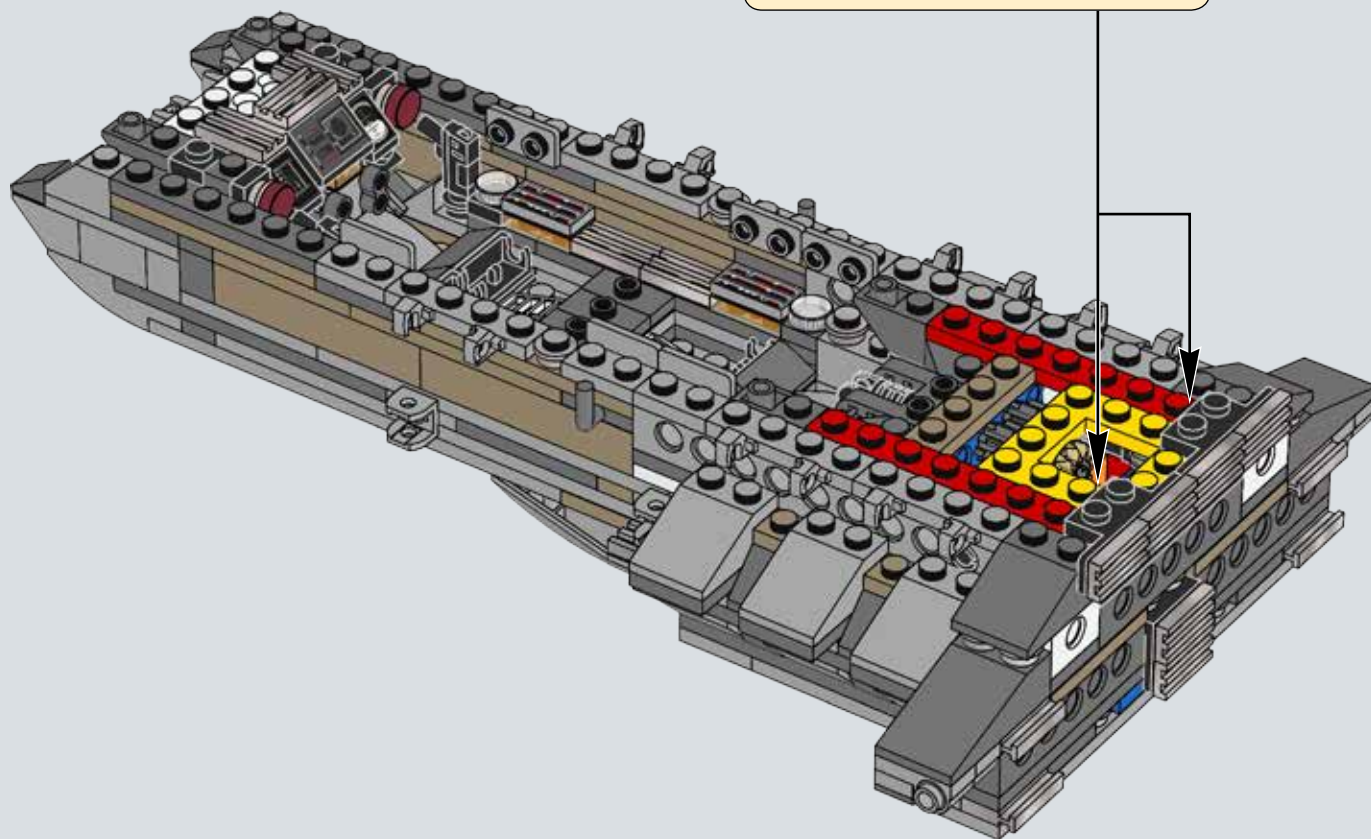
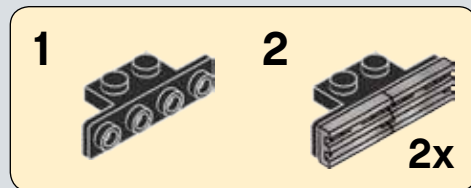

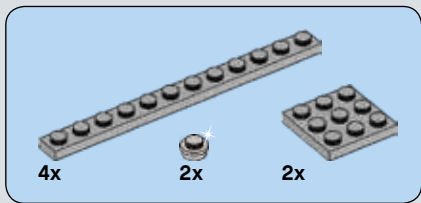

74

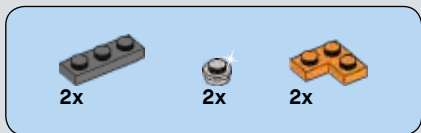
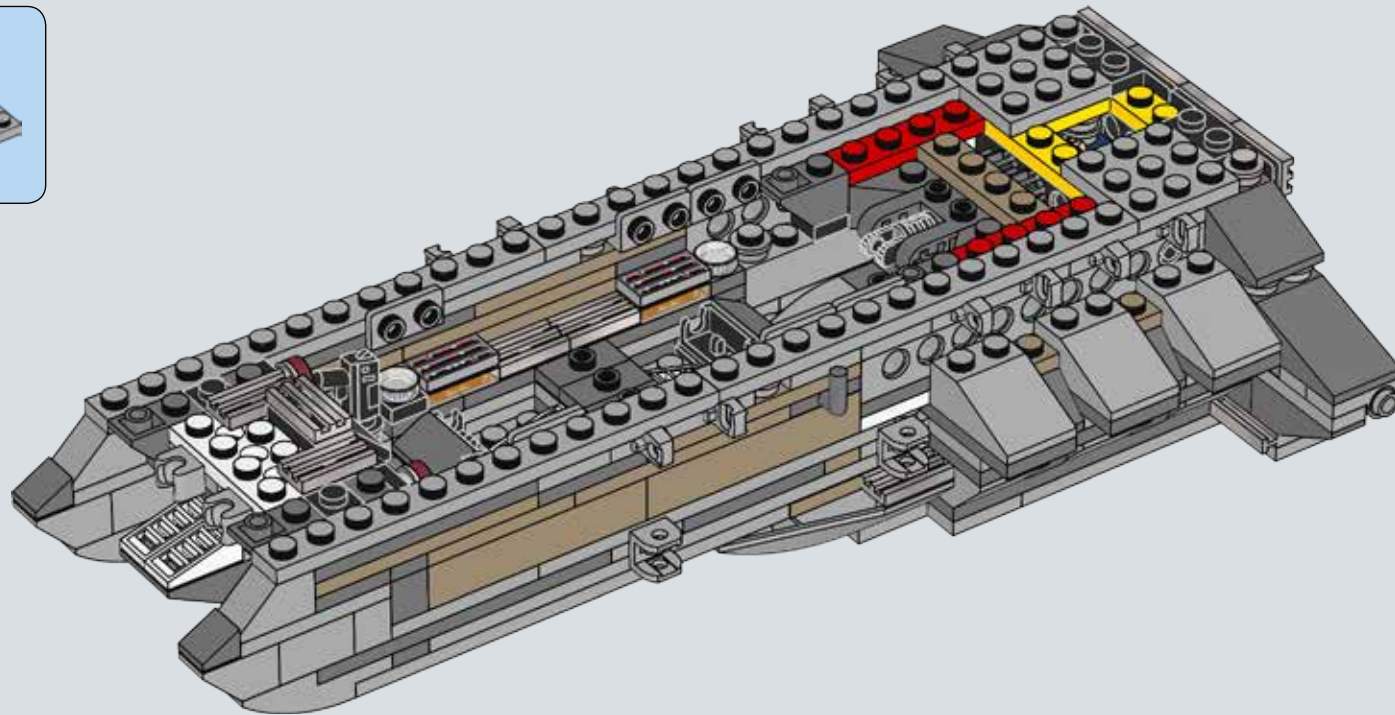

75

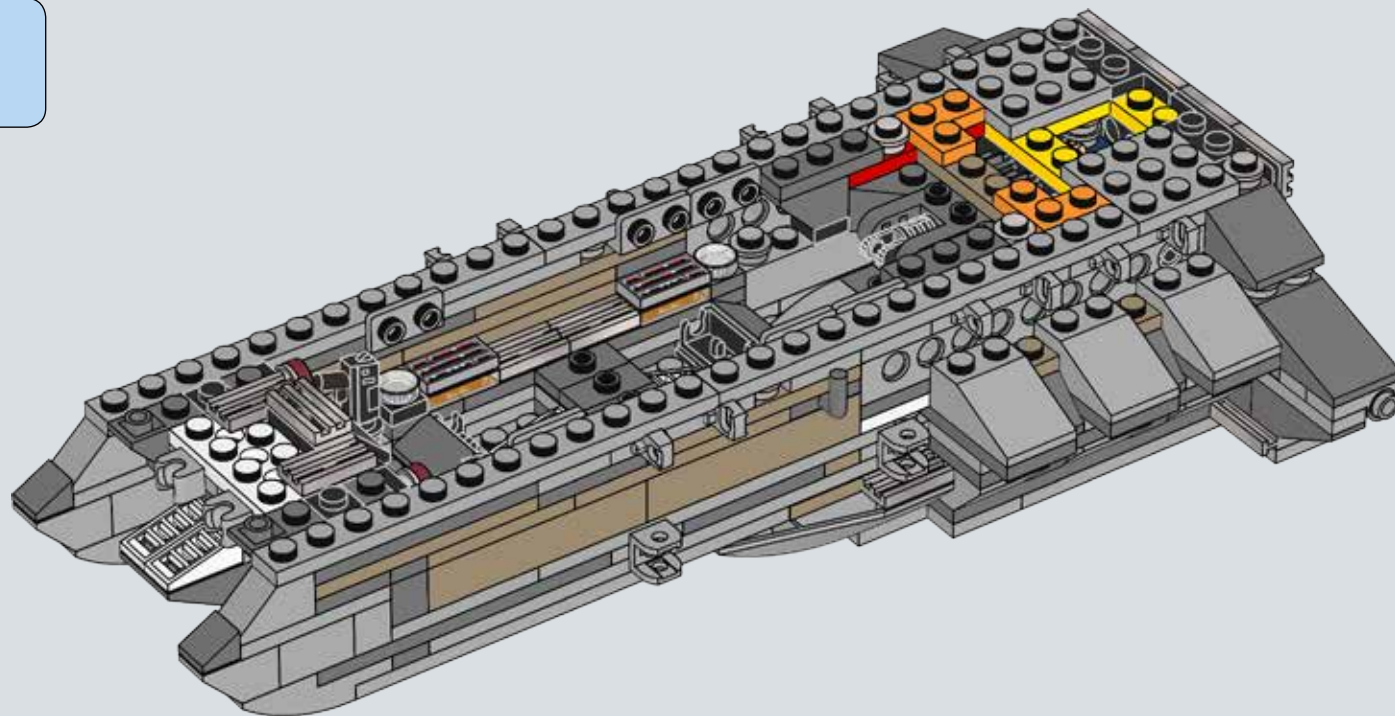



76

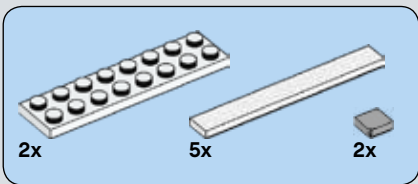
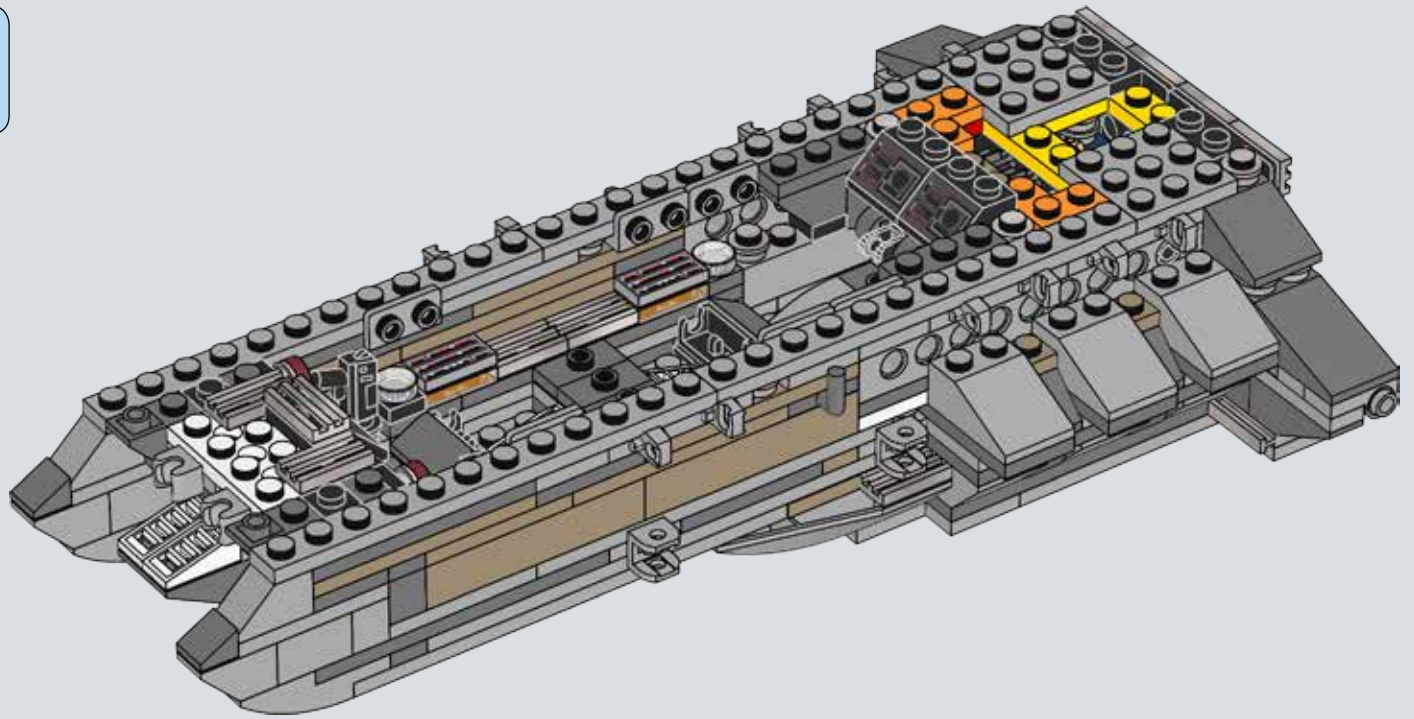

77

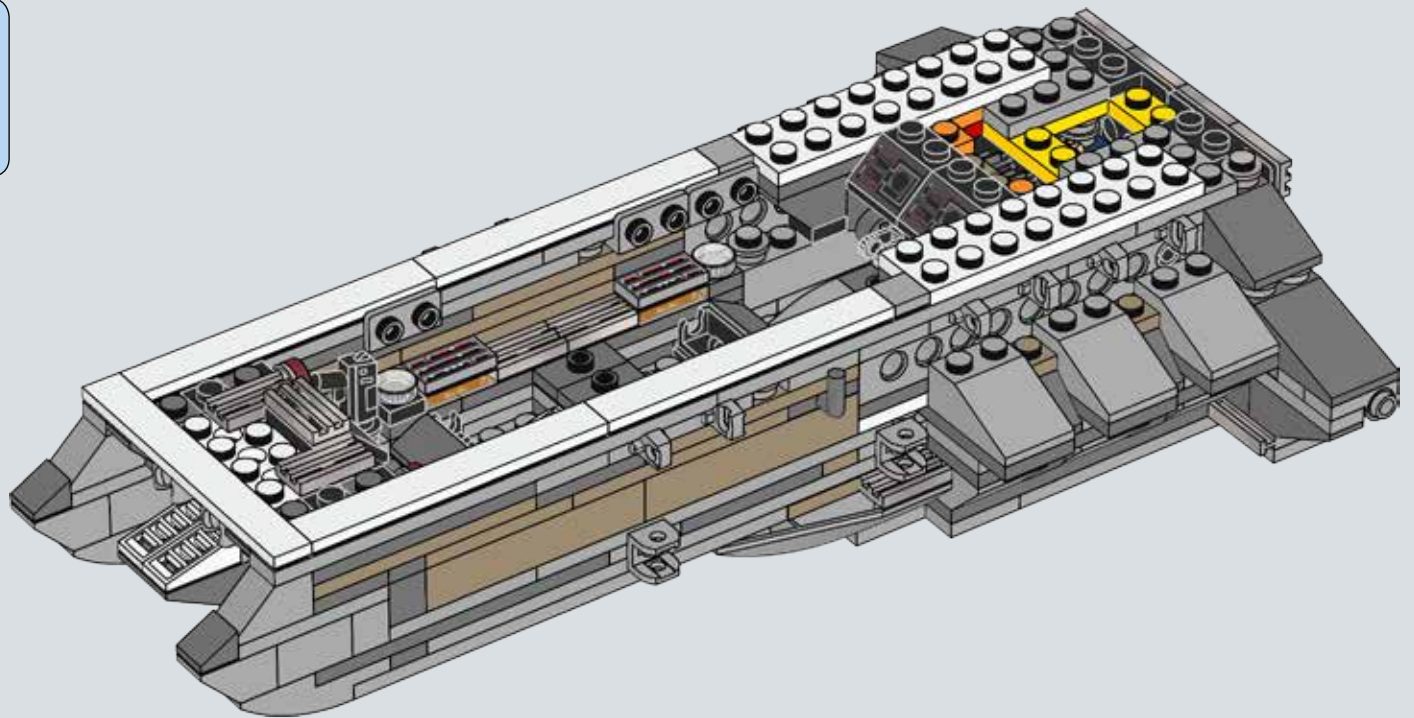

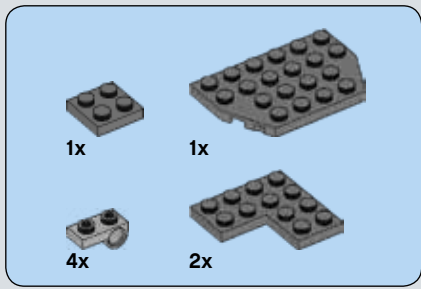

78

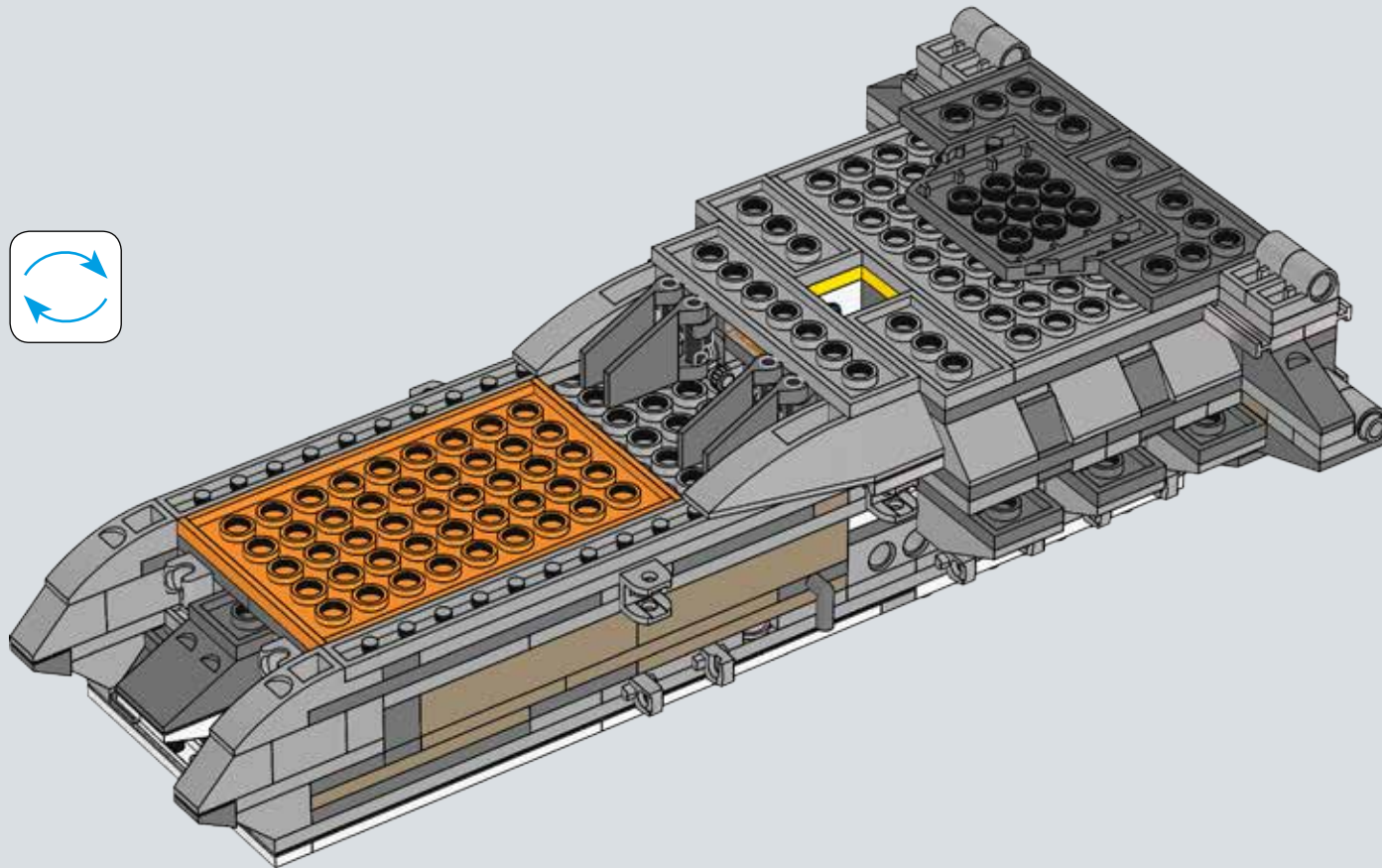

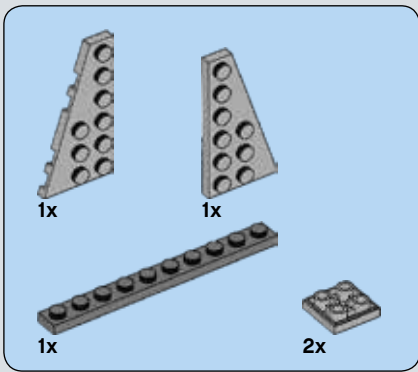

79

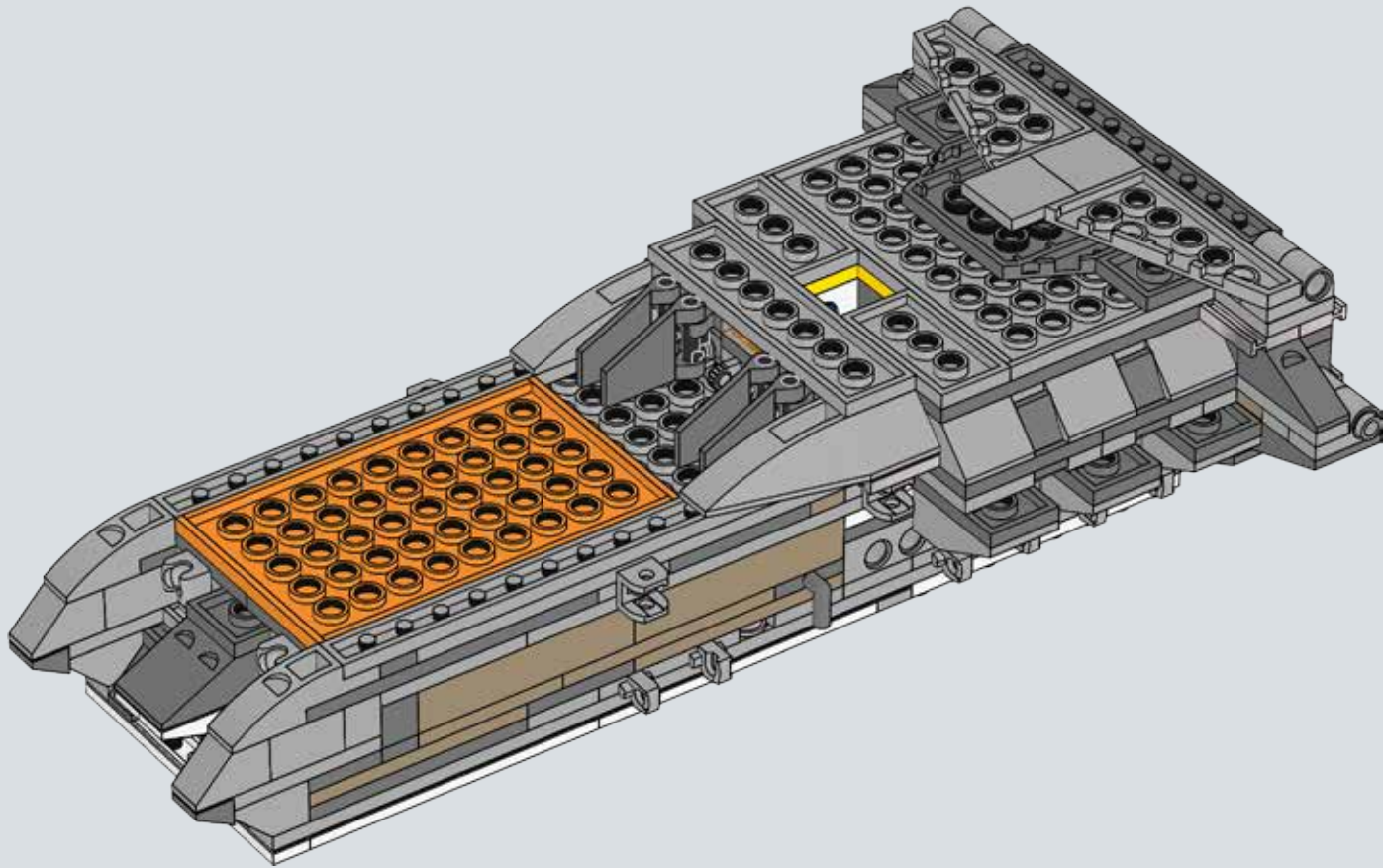



8x

80

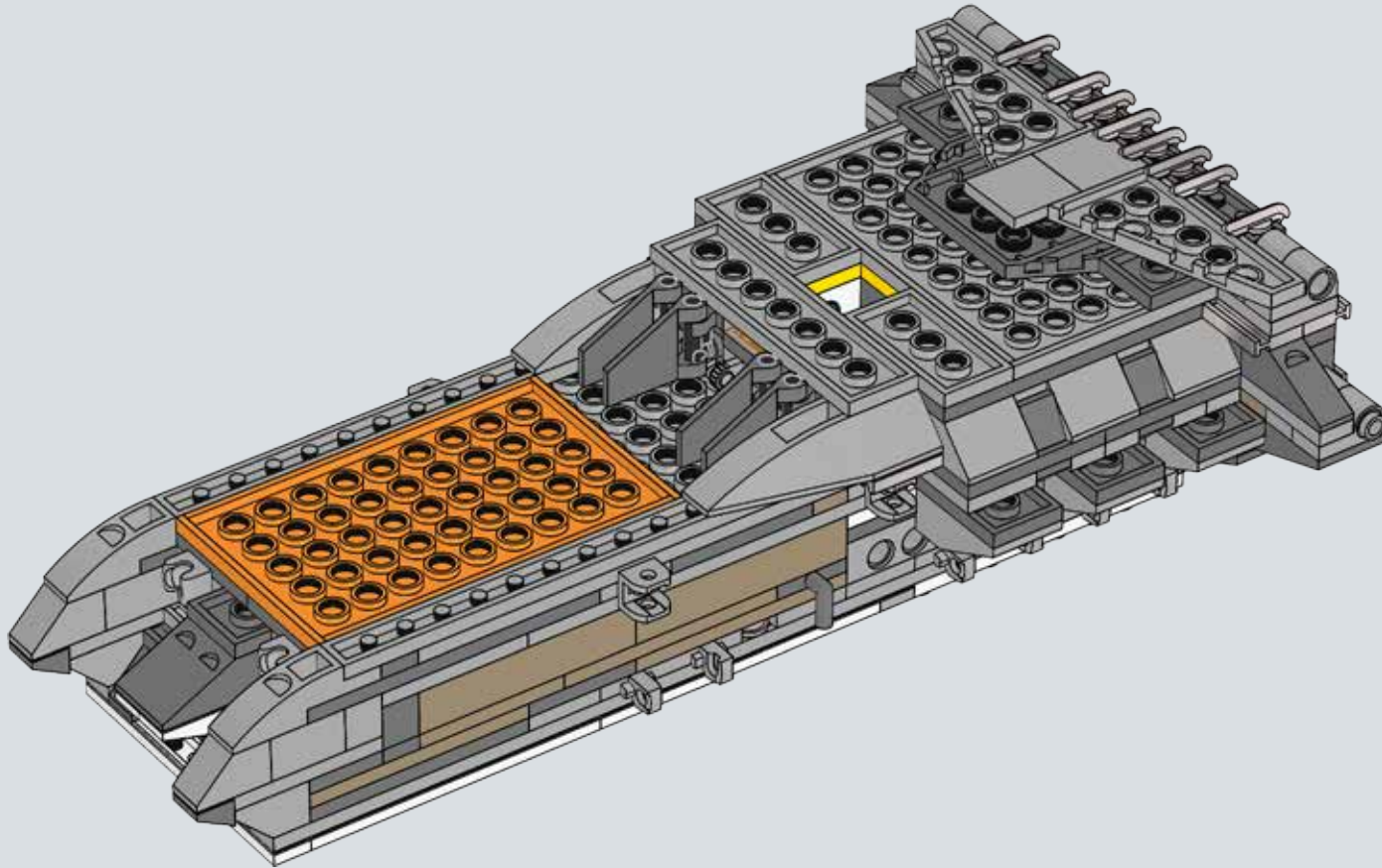



2x

81

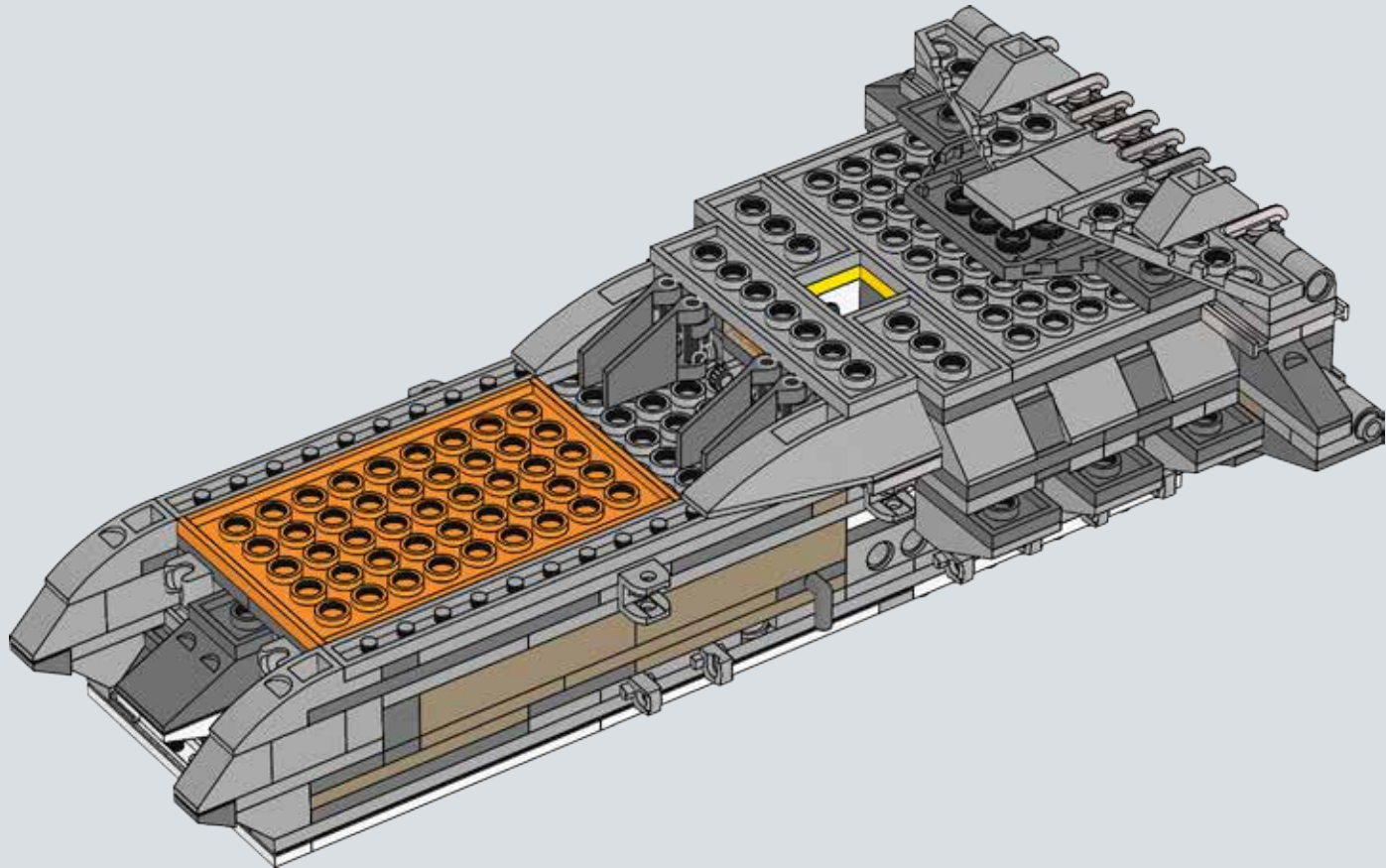

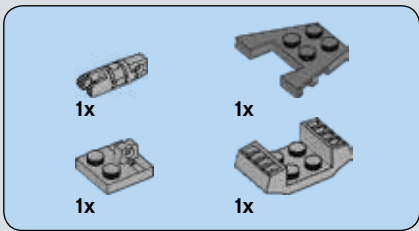

82

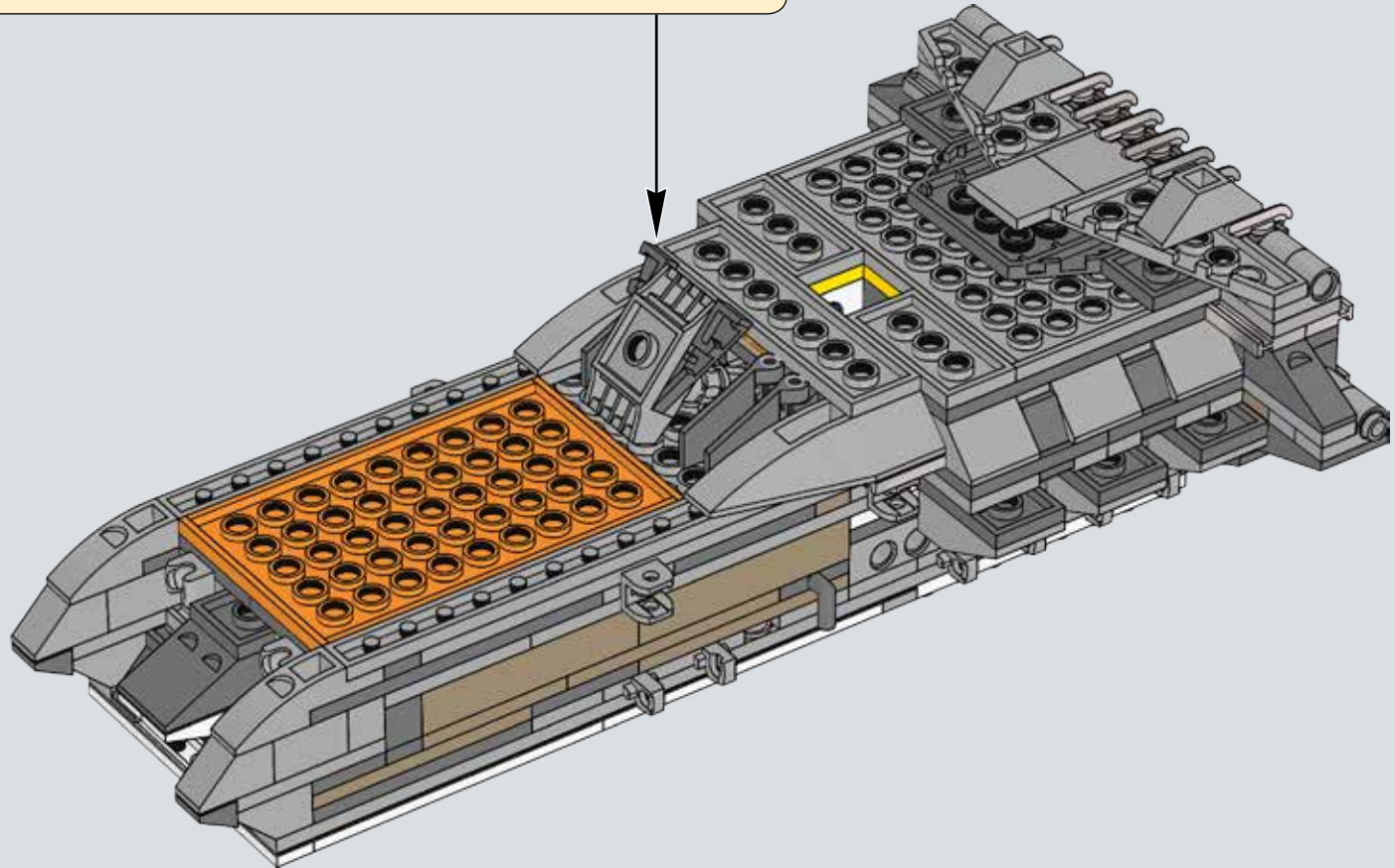
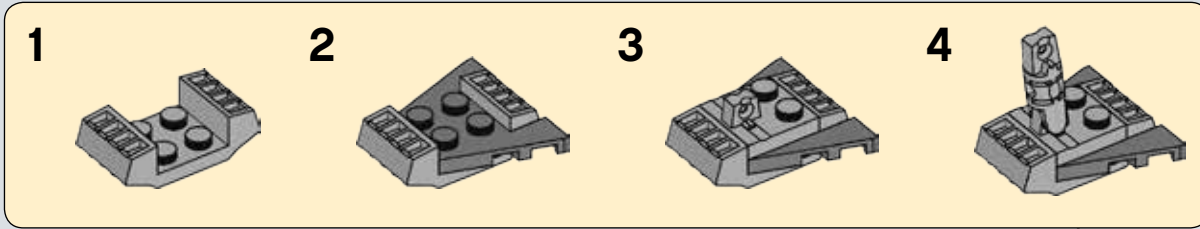

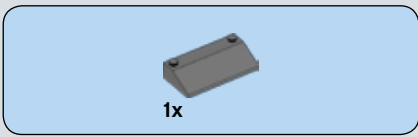

83

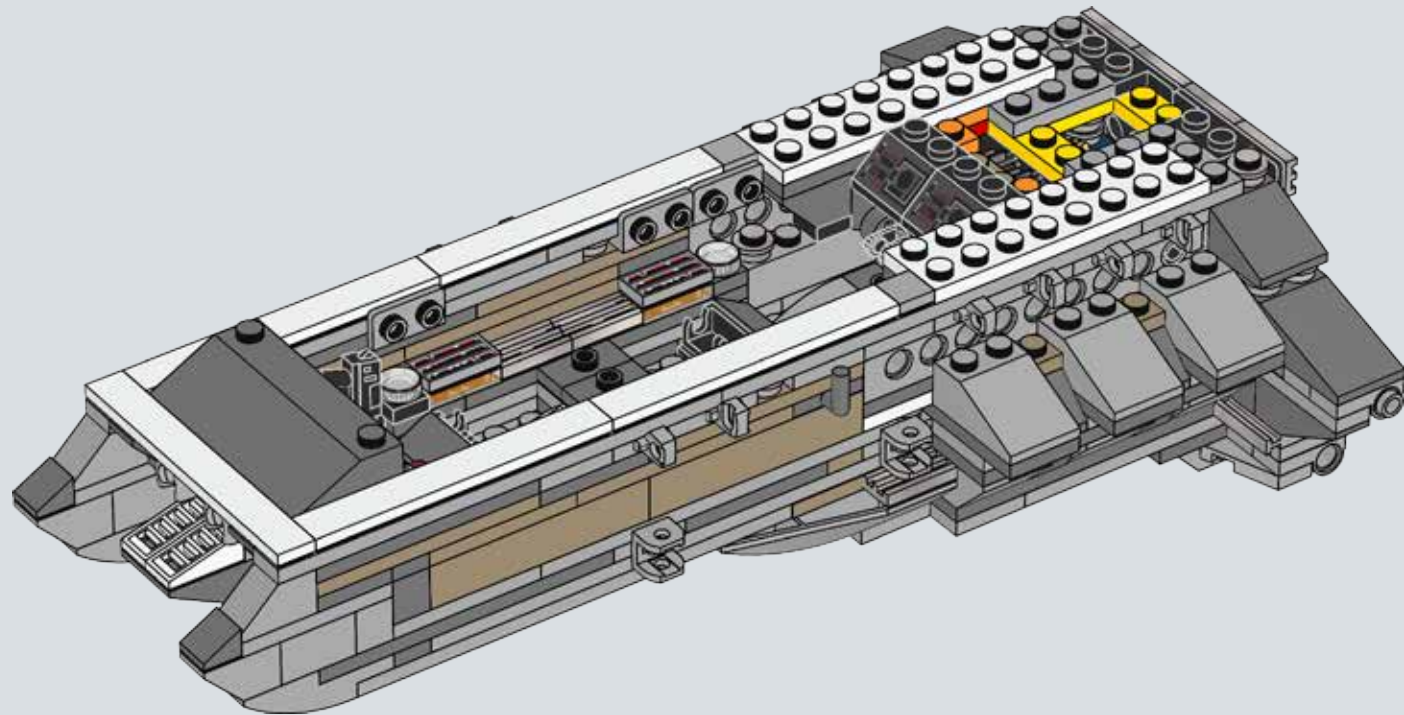
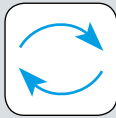

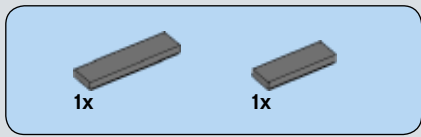

84

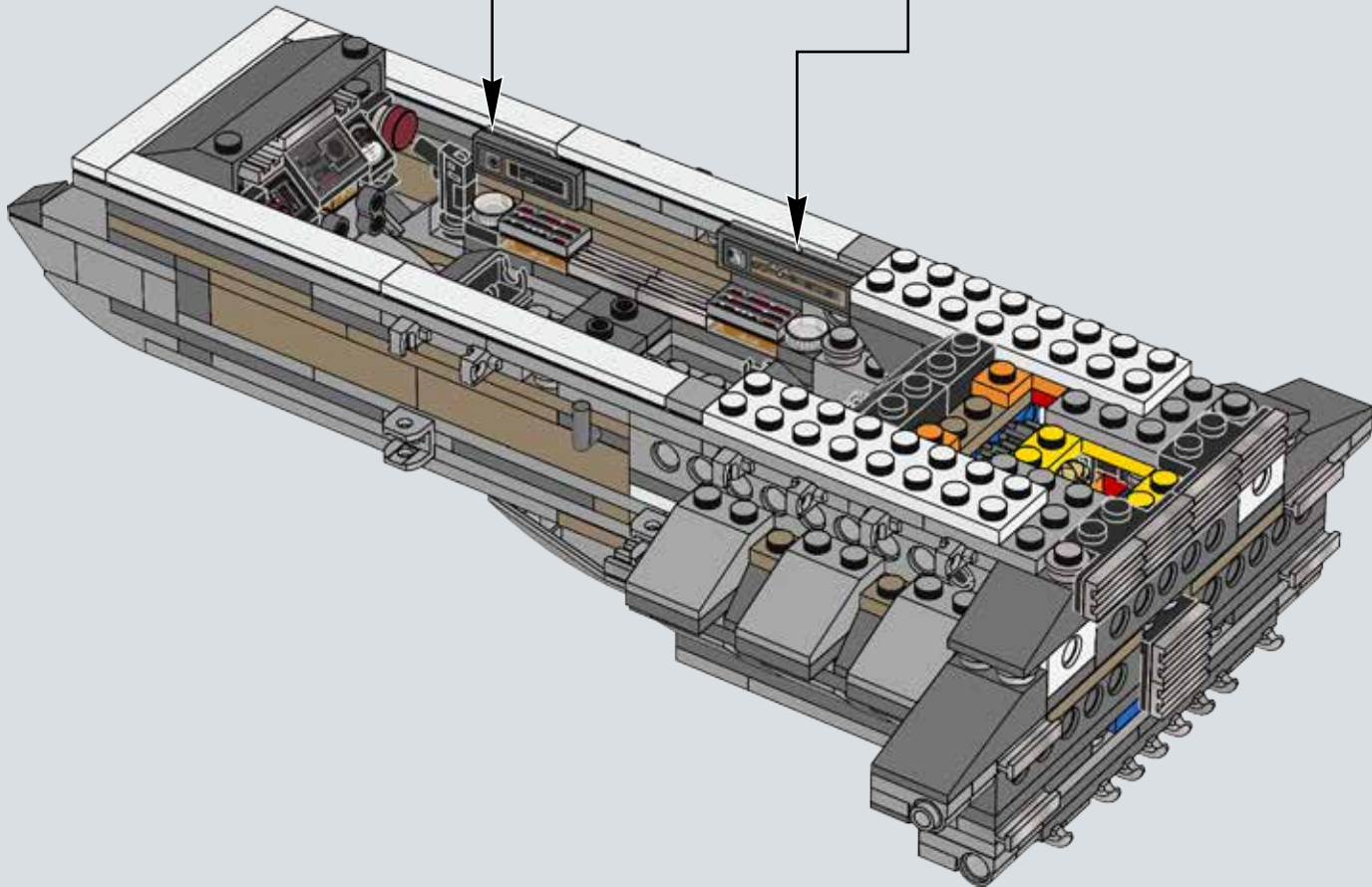
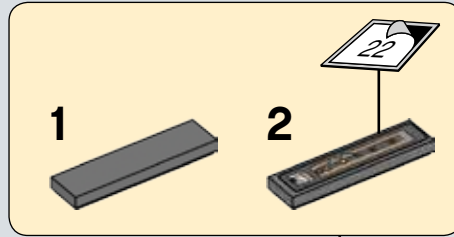
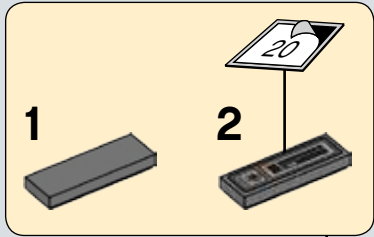

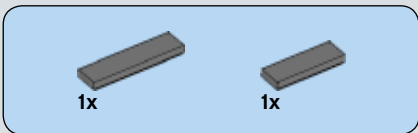

85

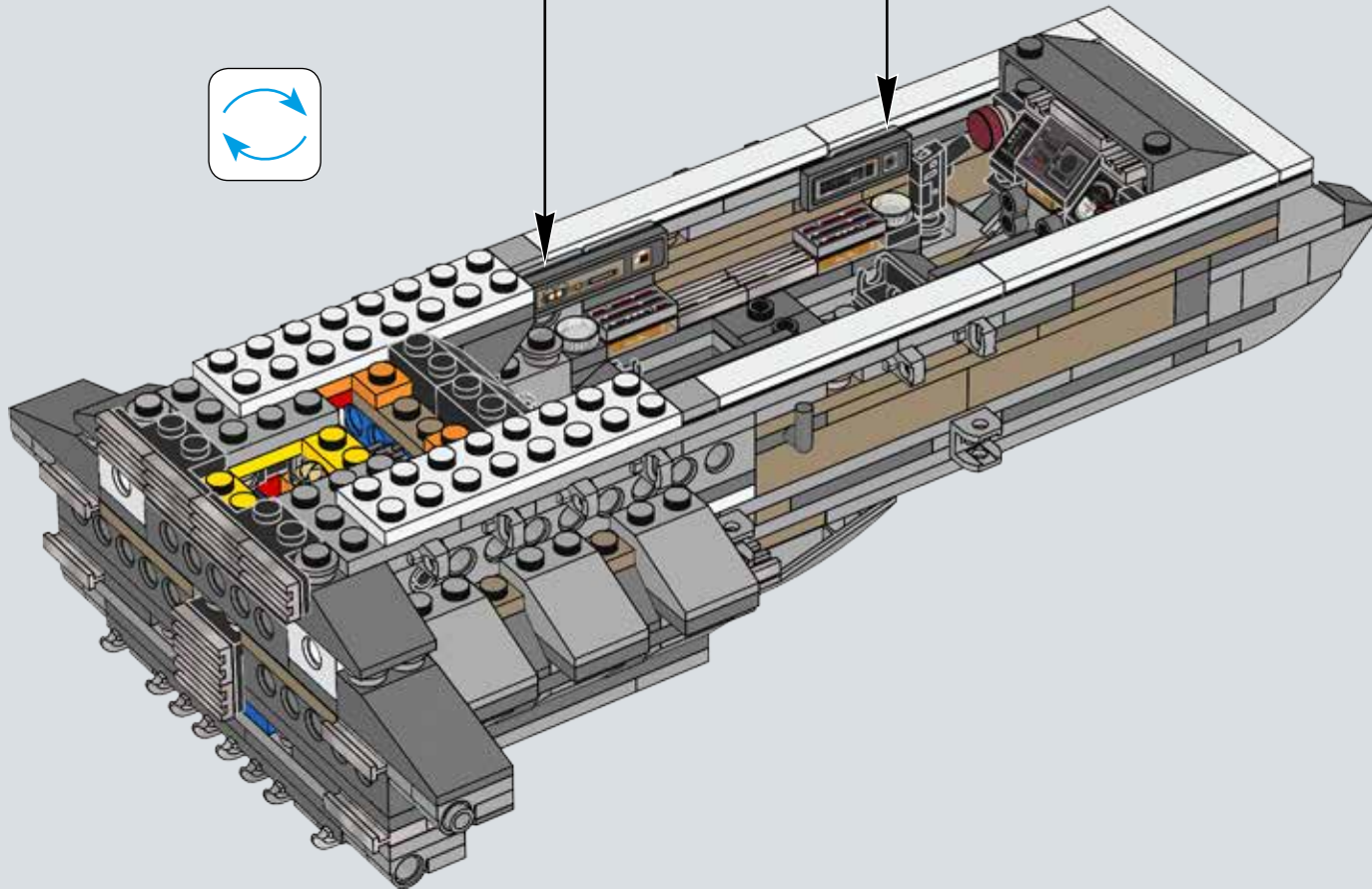
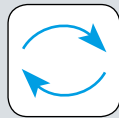
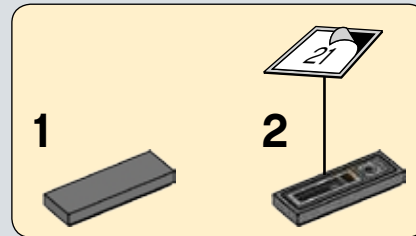
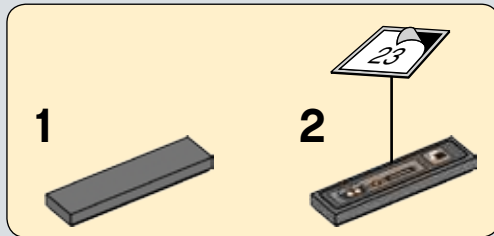

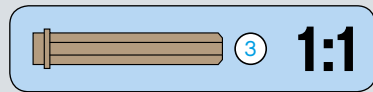

86

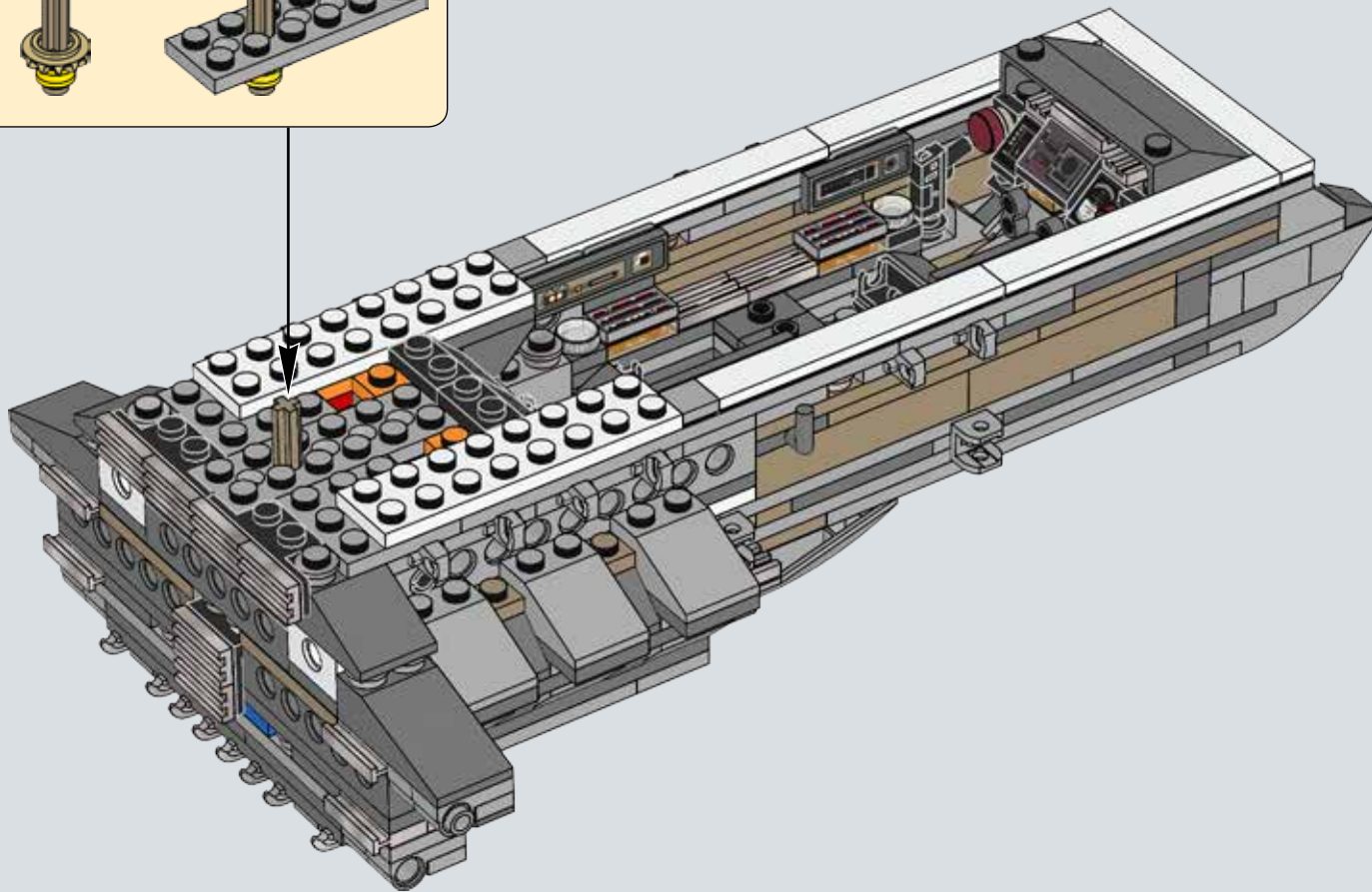
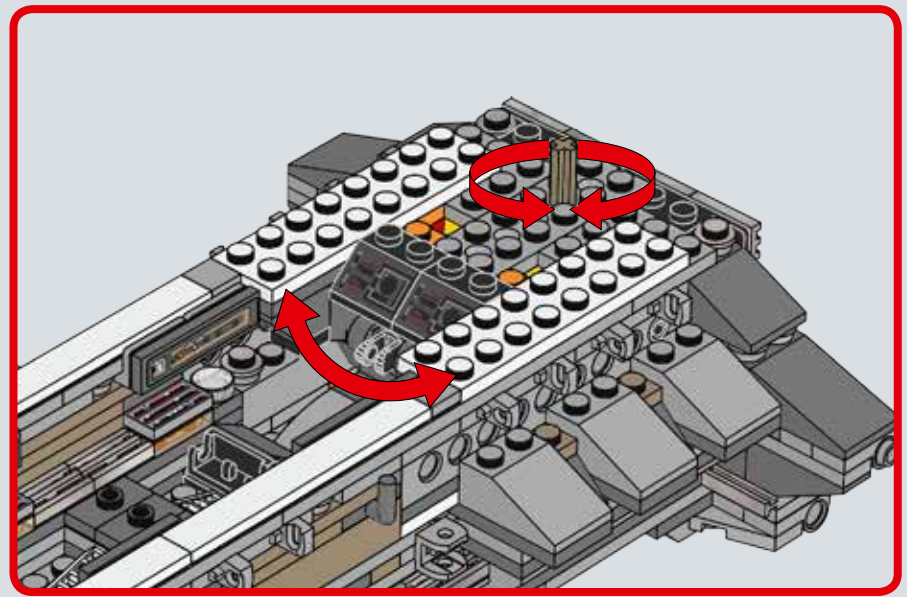

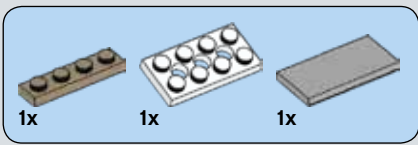

87

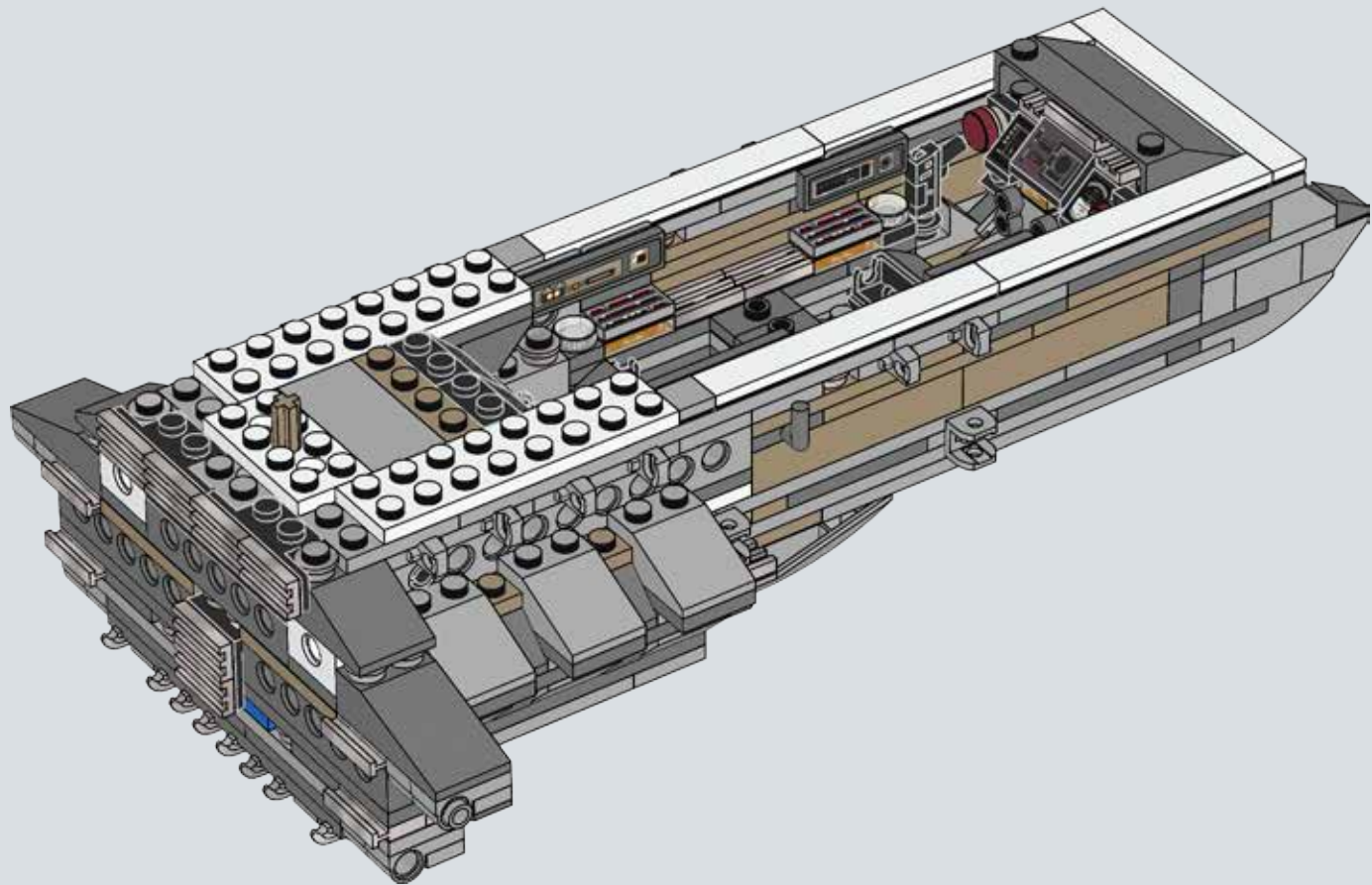

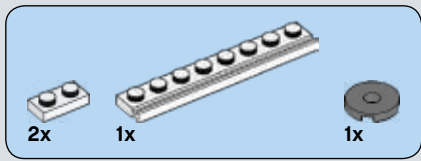

88

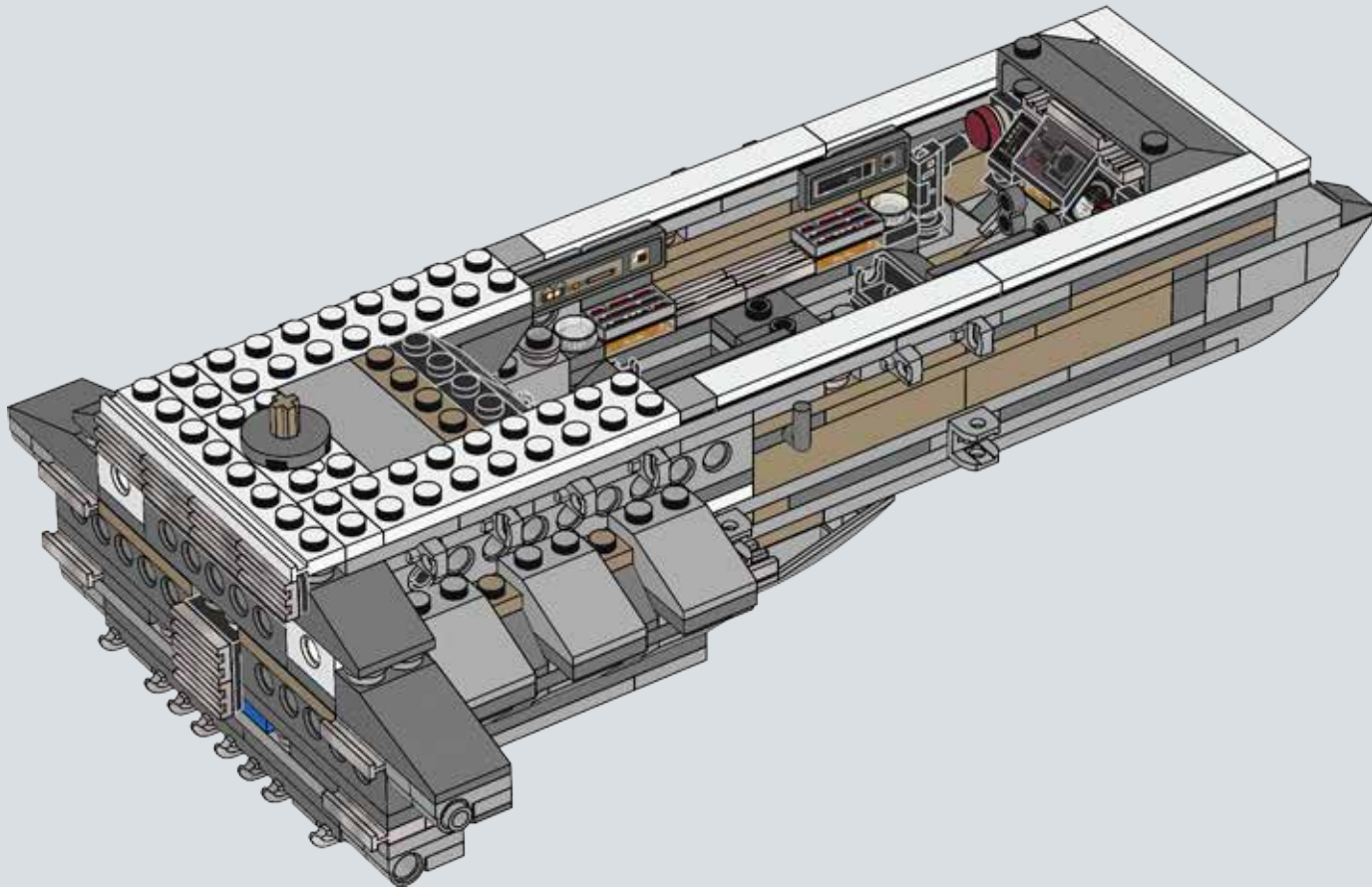



89

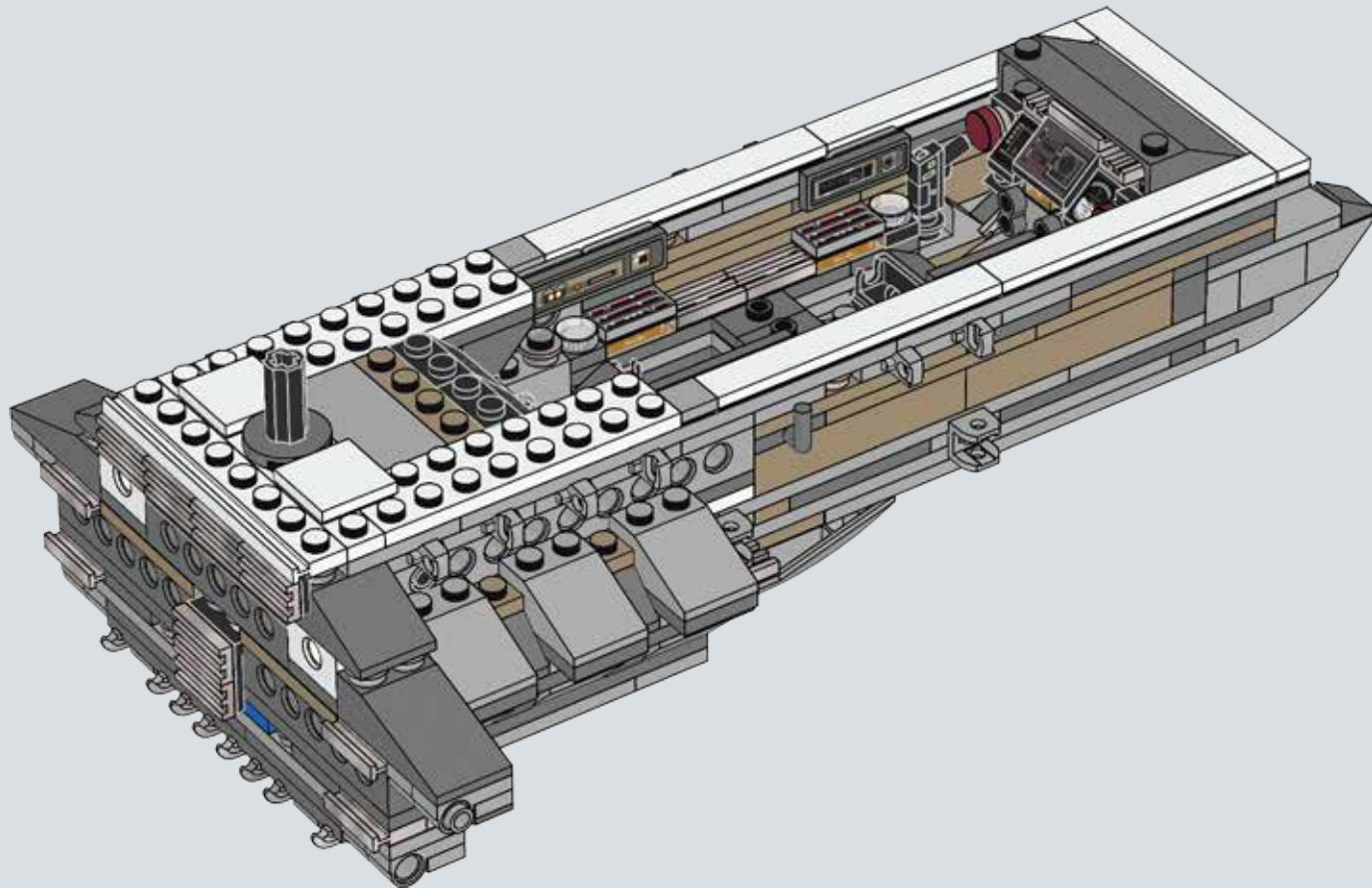

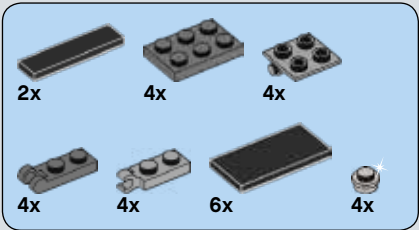
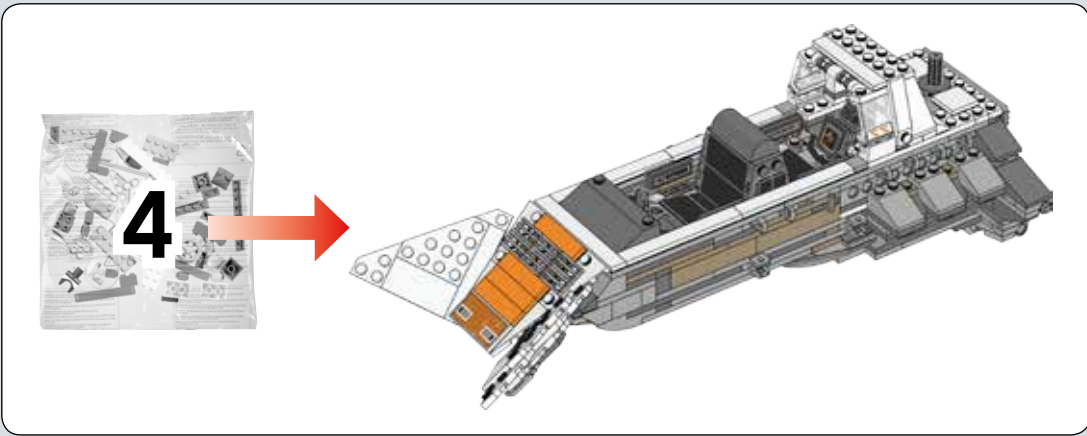

90

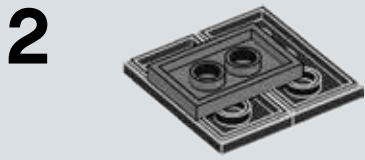
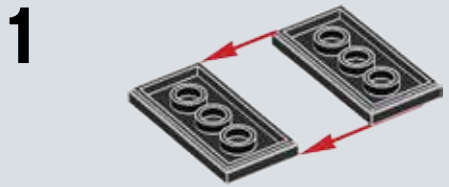

3

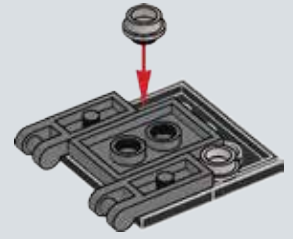

4

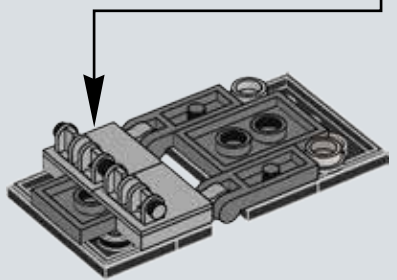
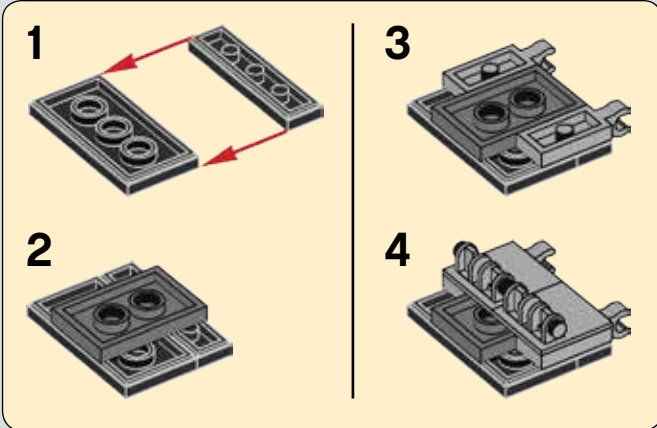

5

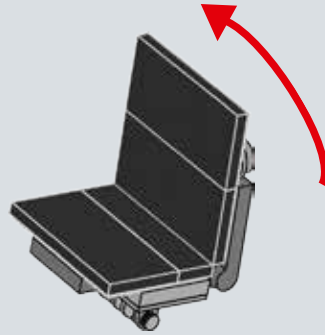
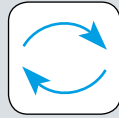

2x

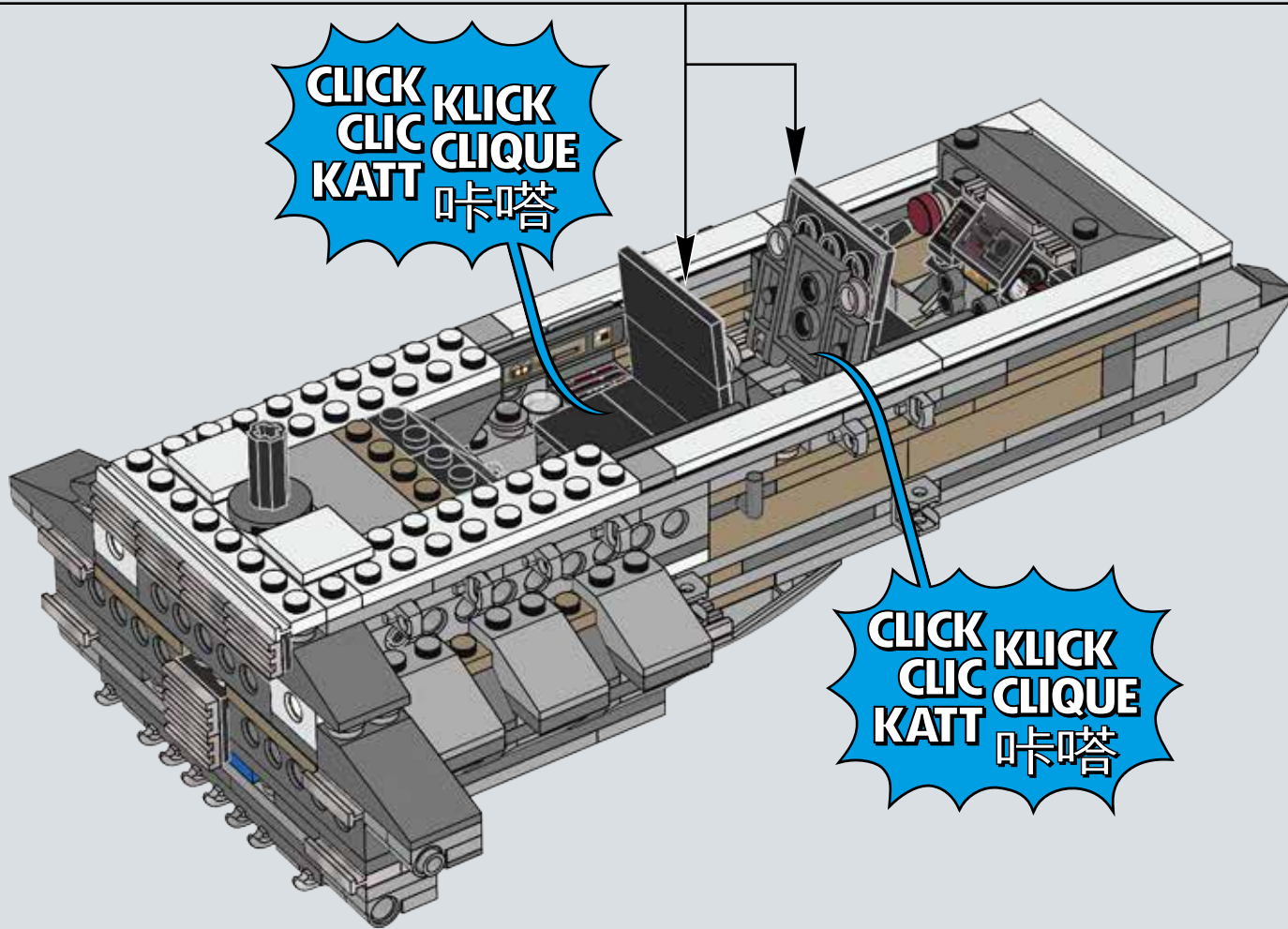

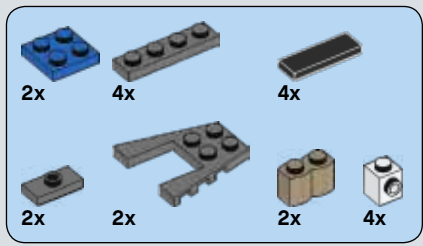

91

1

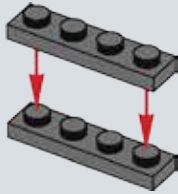

2

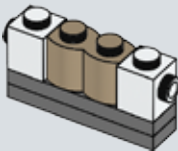

3

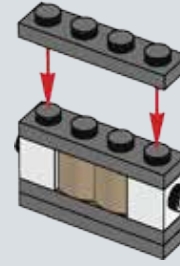

4

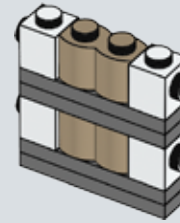

5

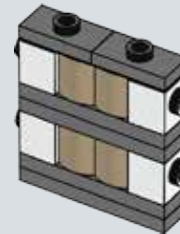

6

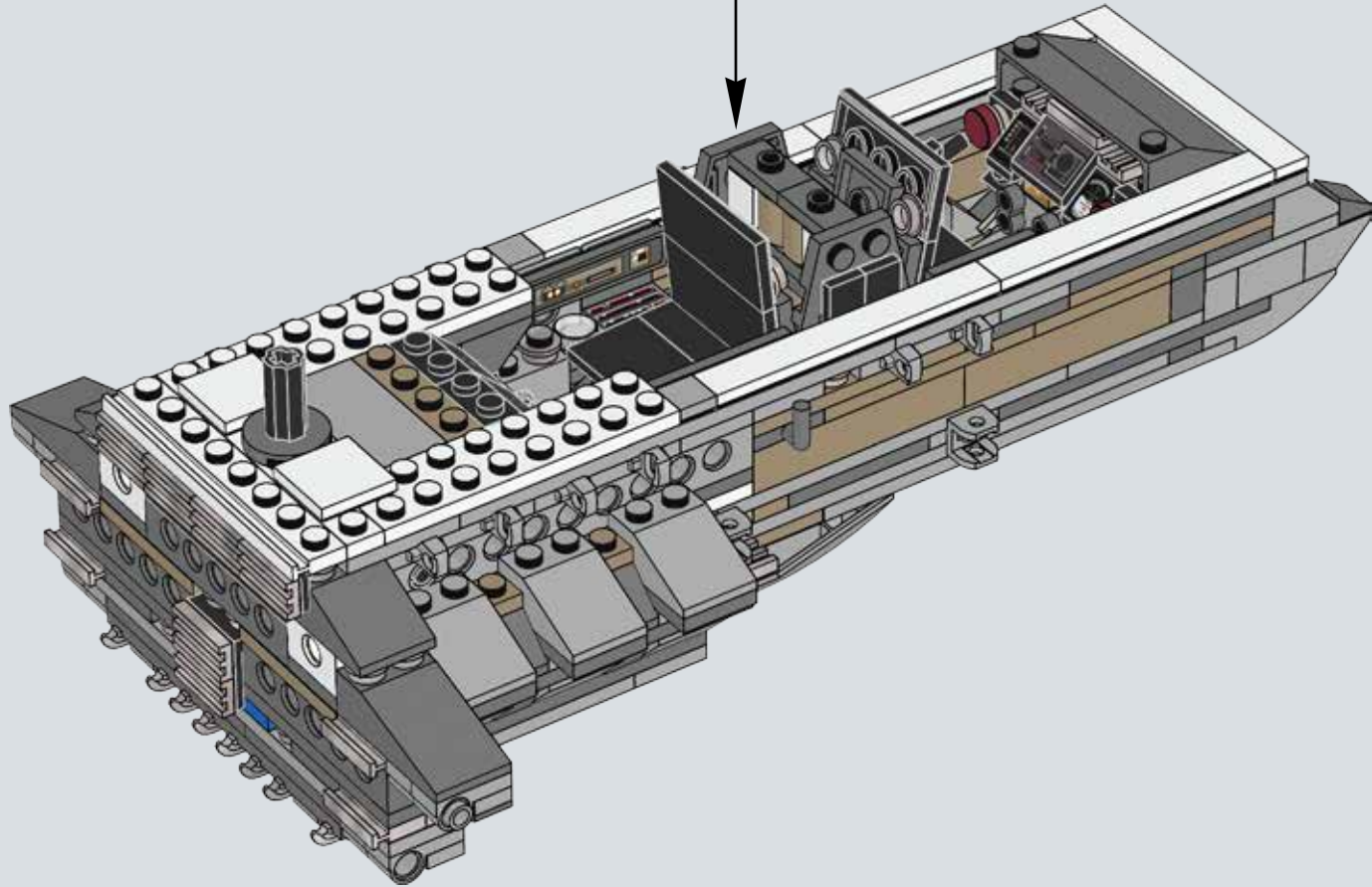
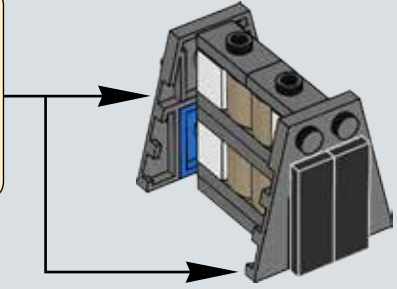
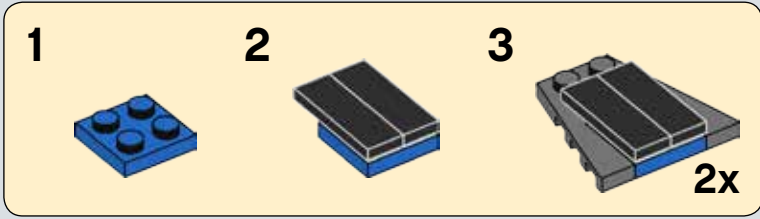

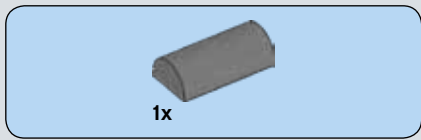

92

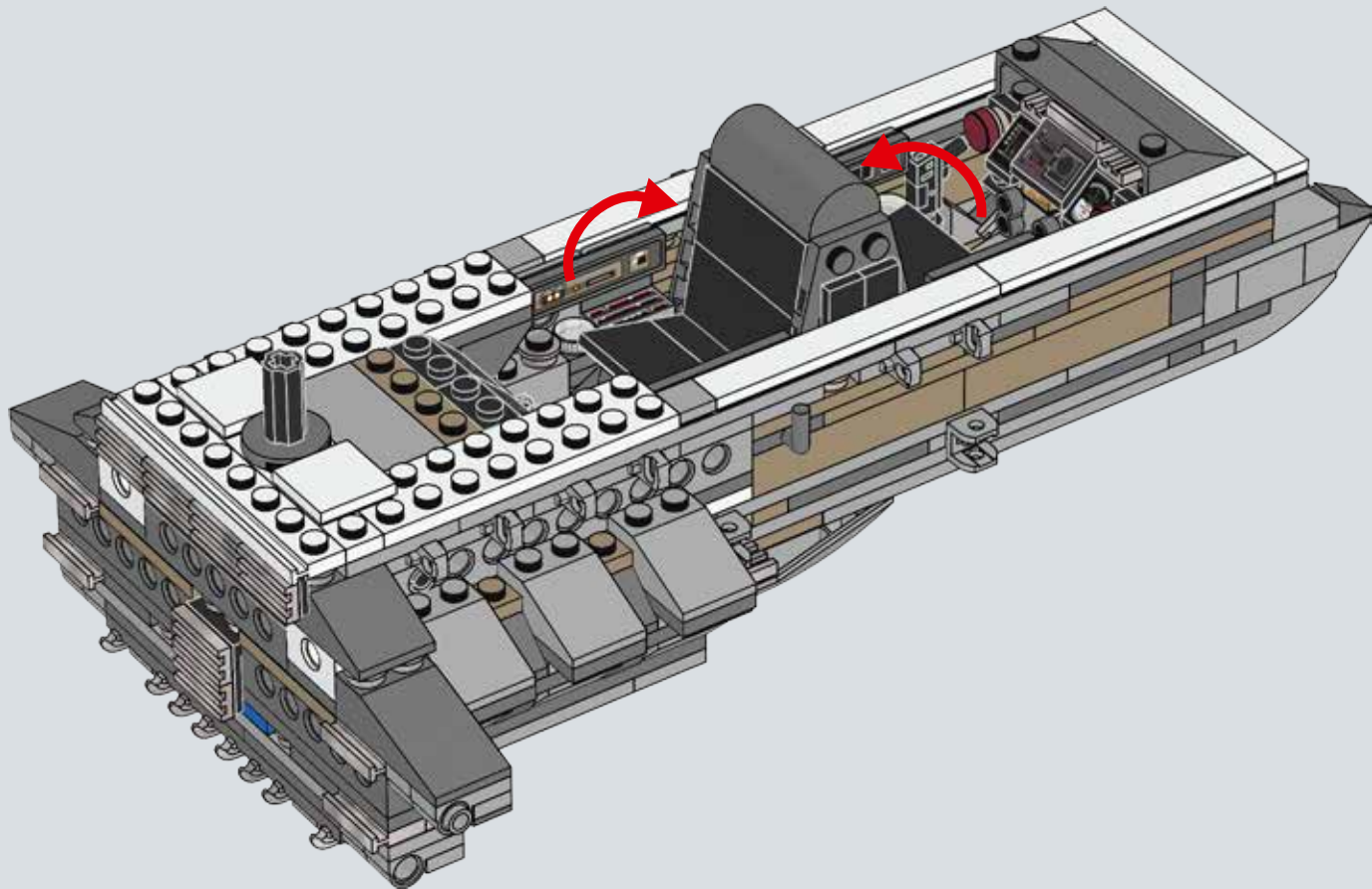

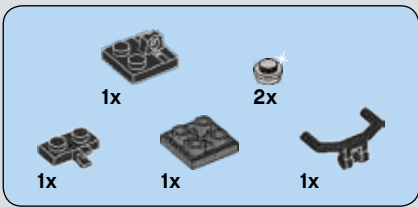

93

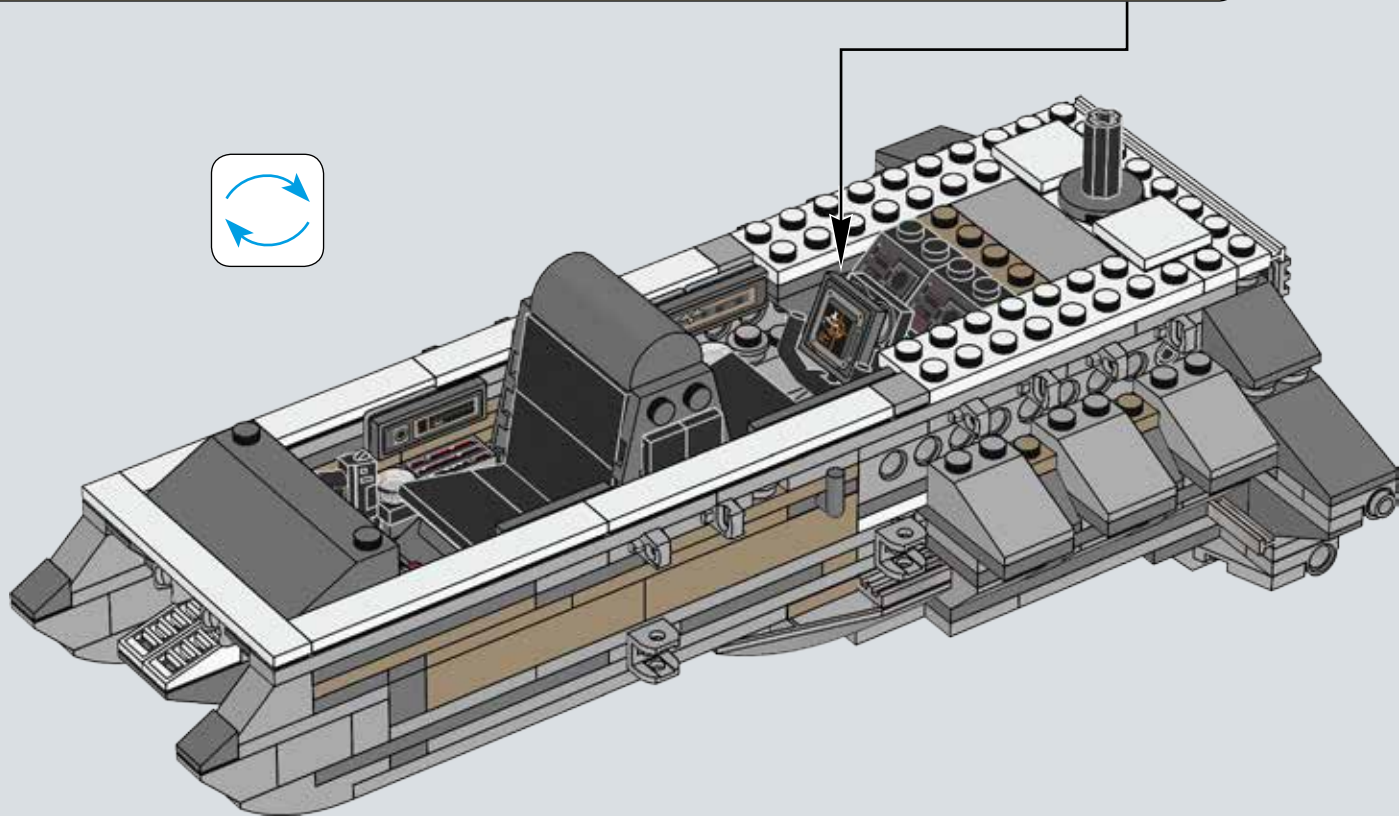
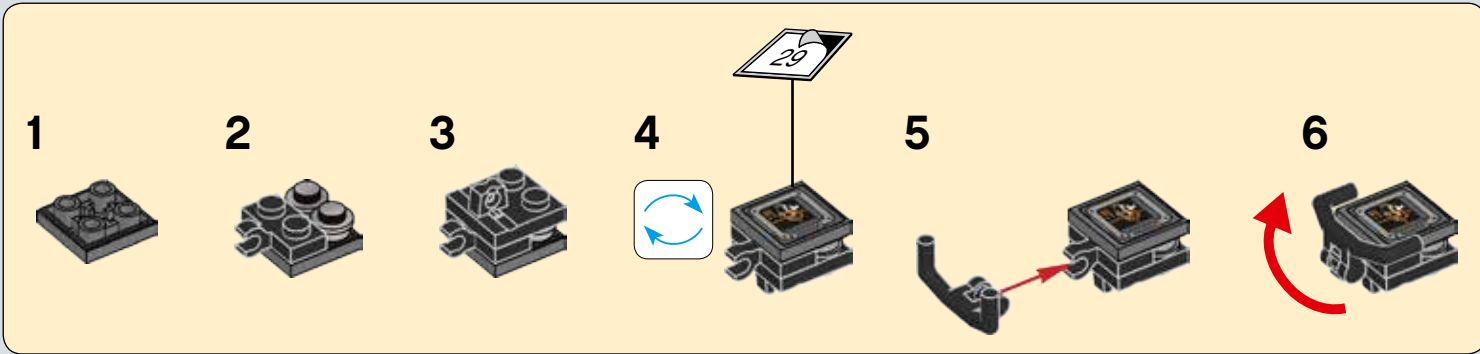

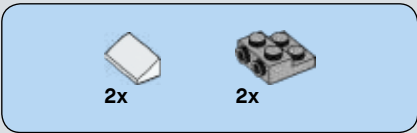

94

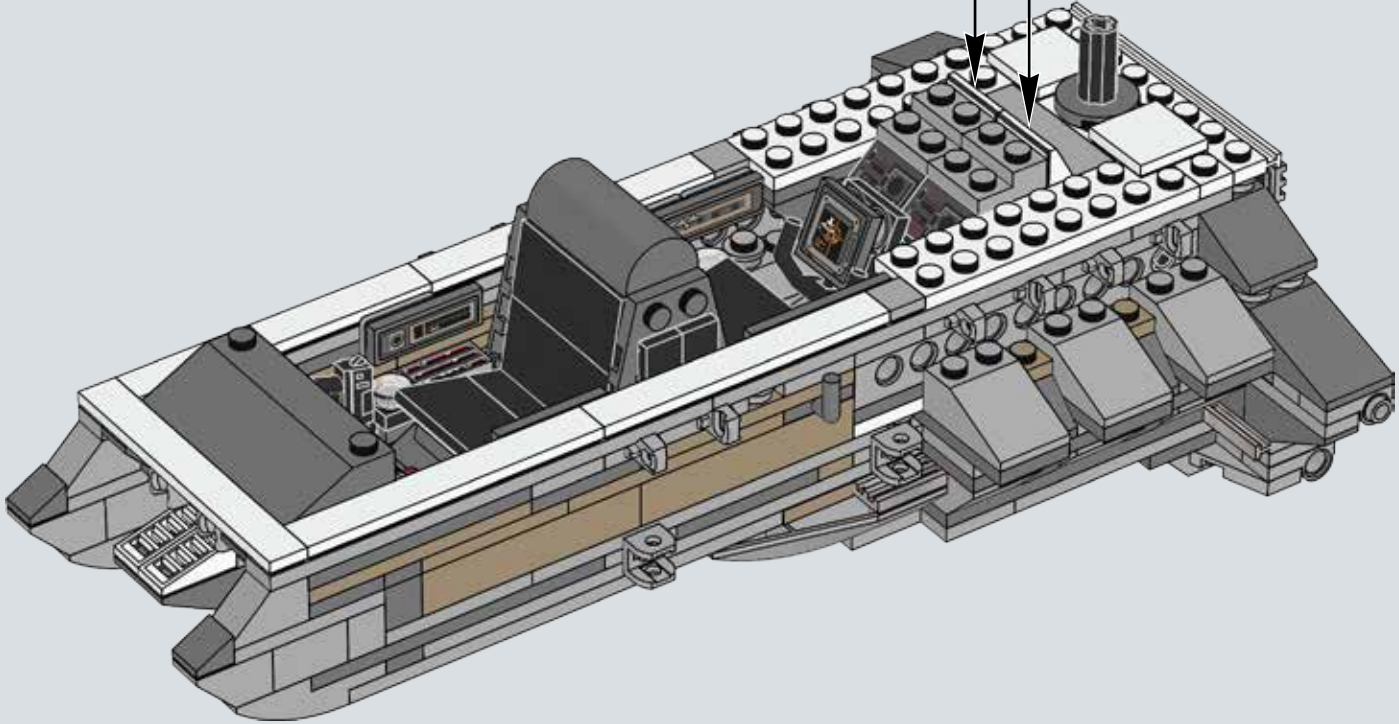
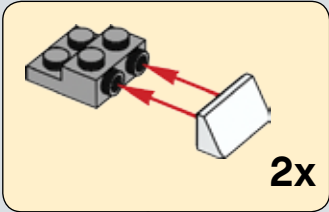



95

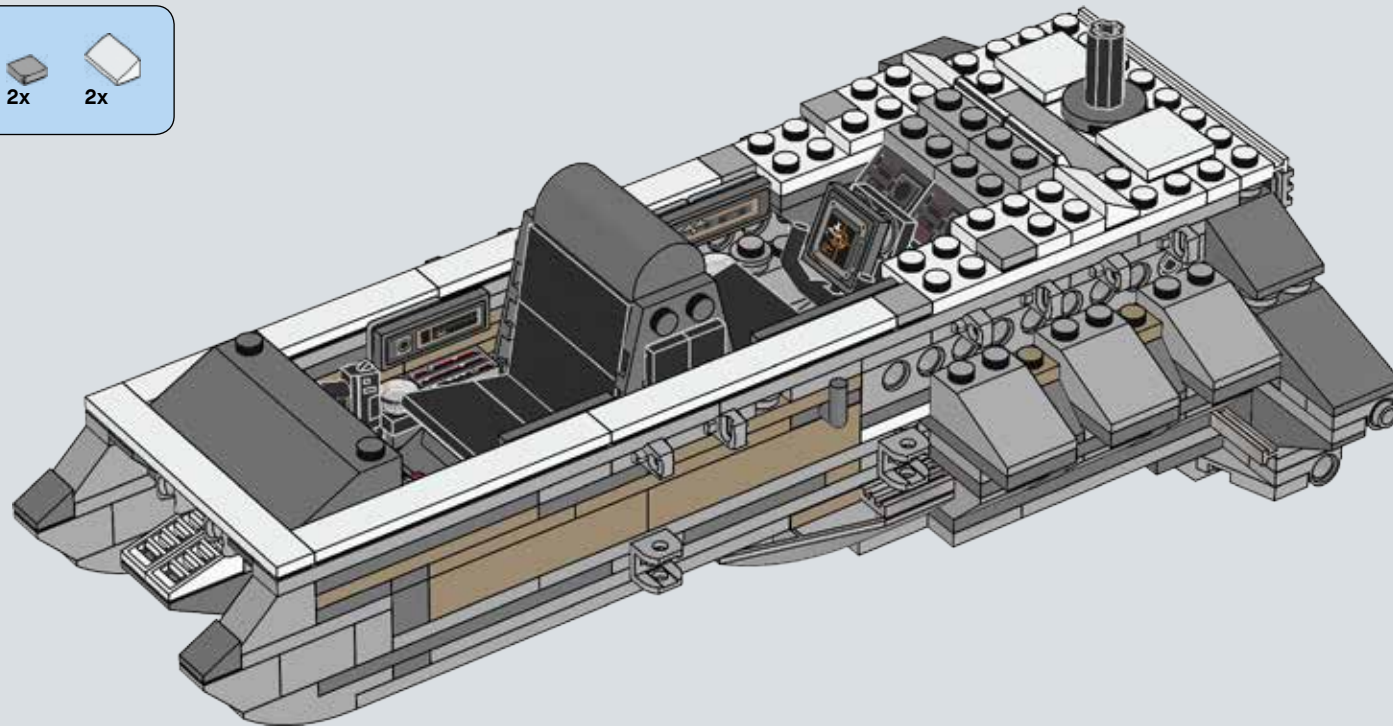

96

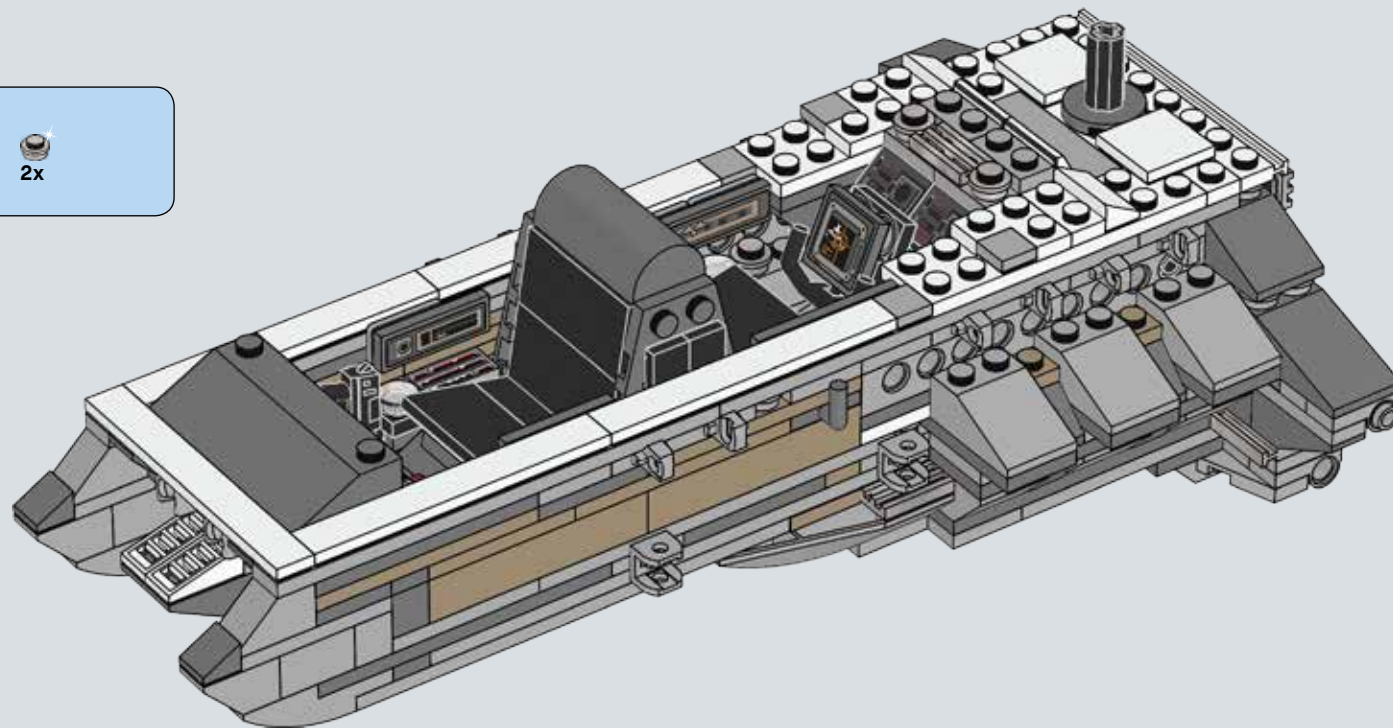



2x

97

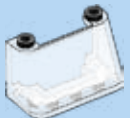
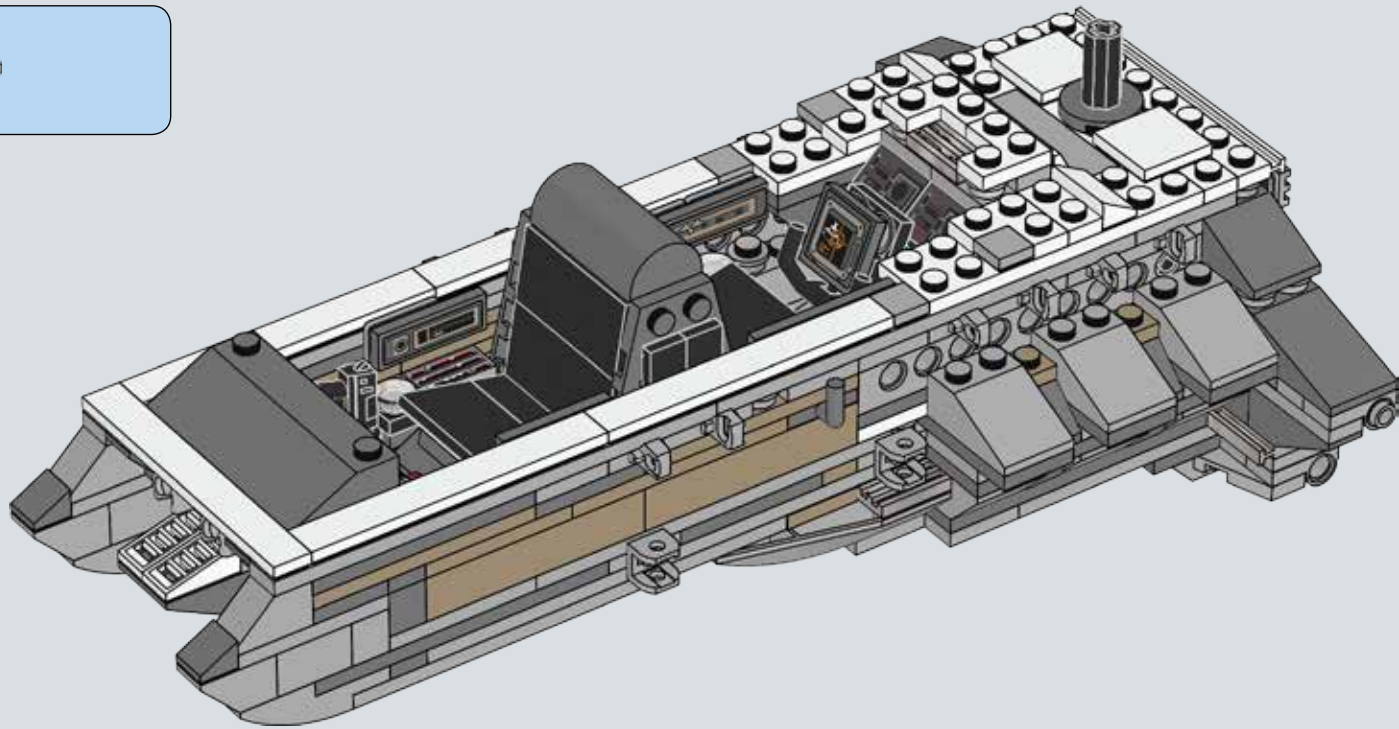



1x



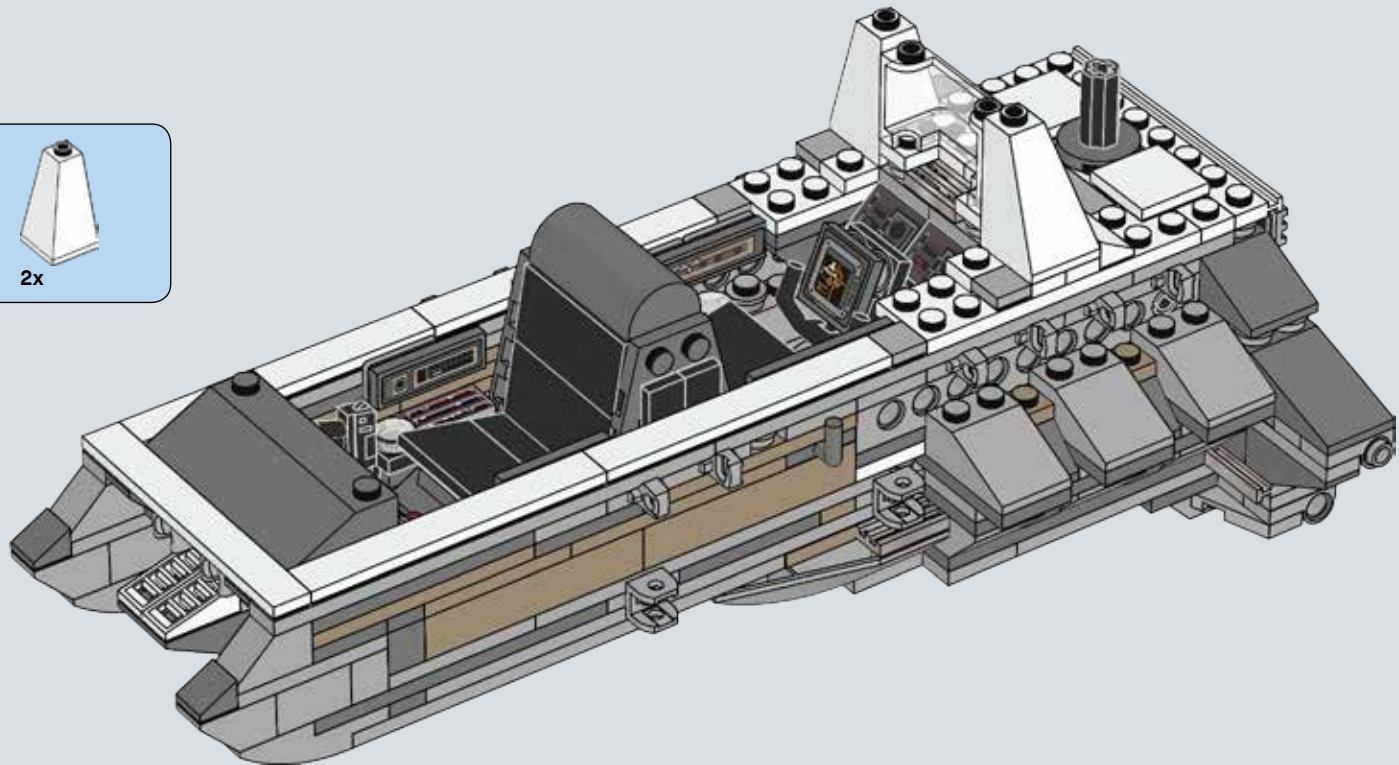

2x

98



4x  2x 

99

1  2 
2x

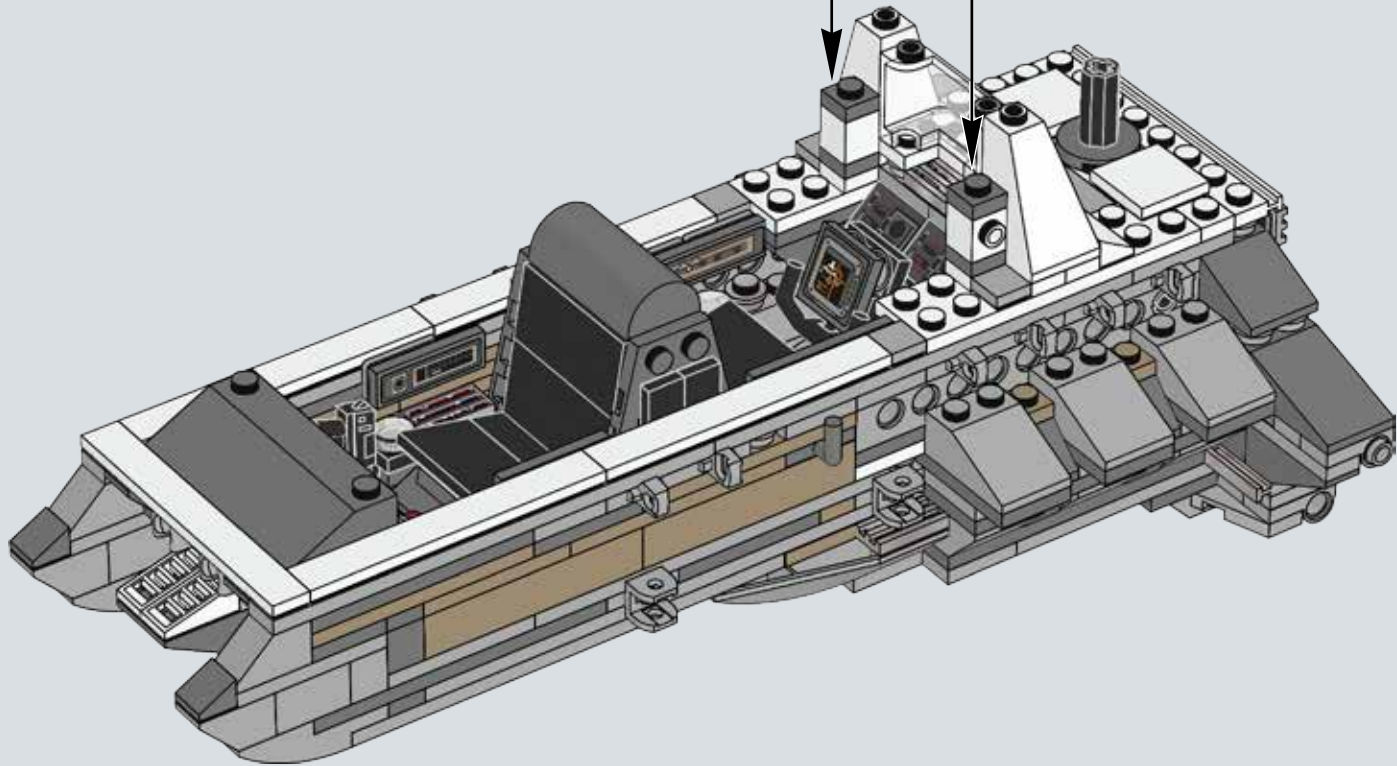

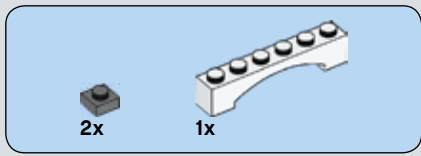

100

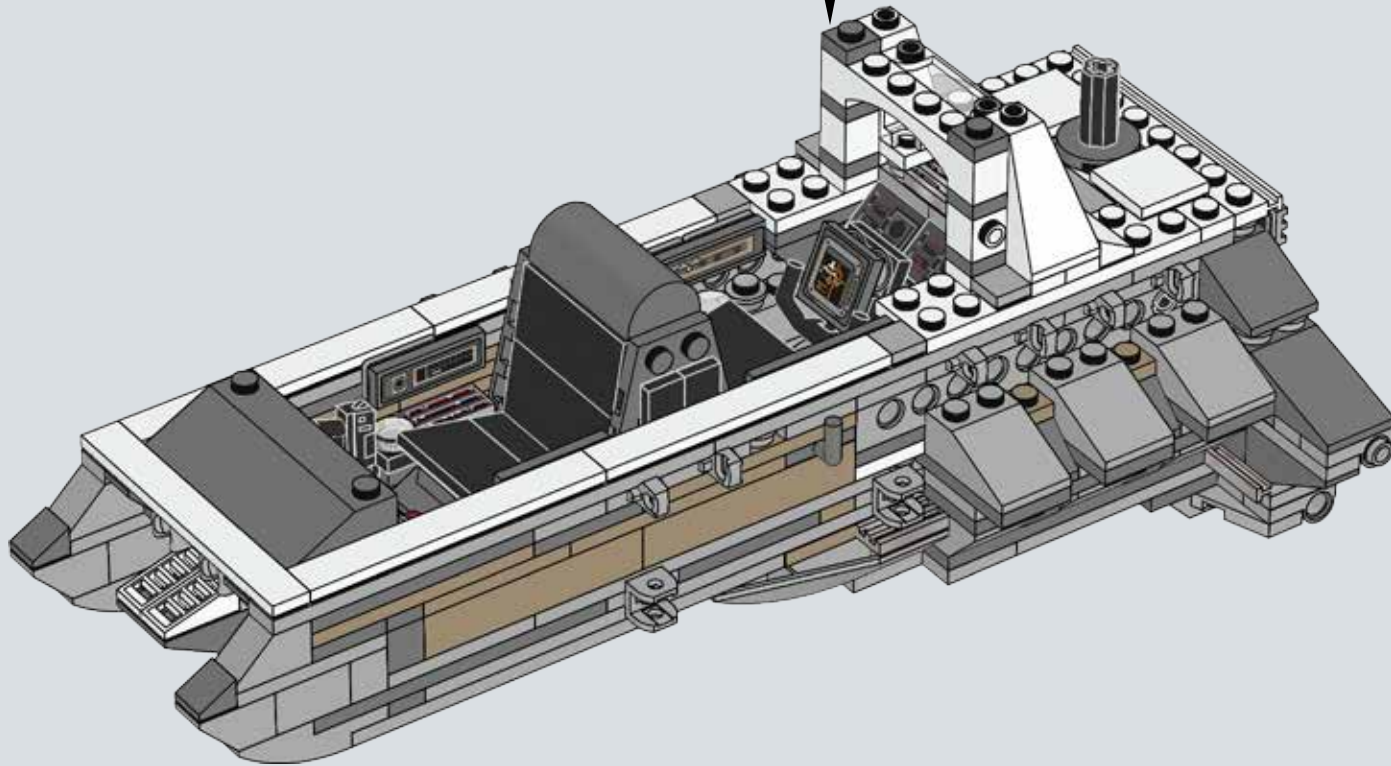
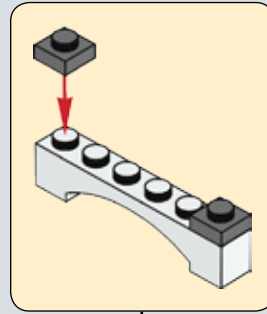

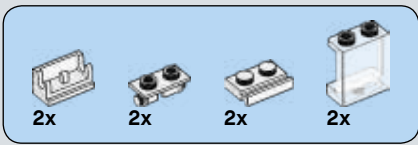

101

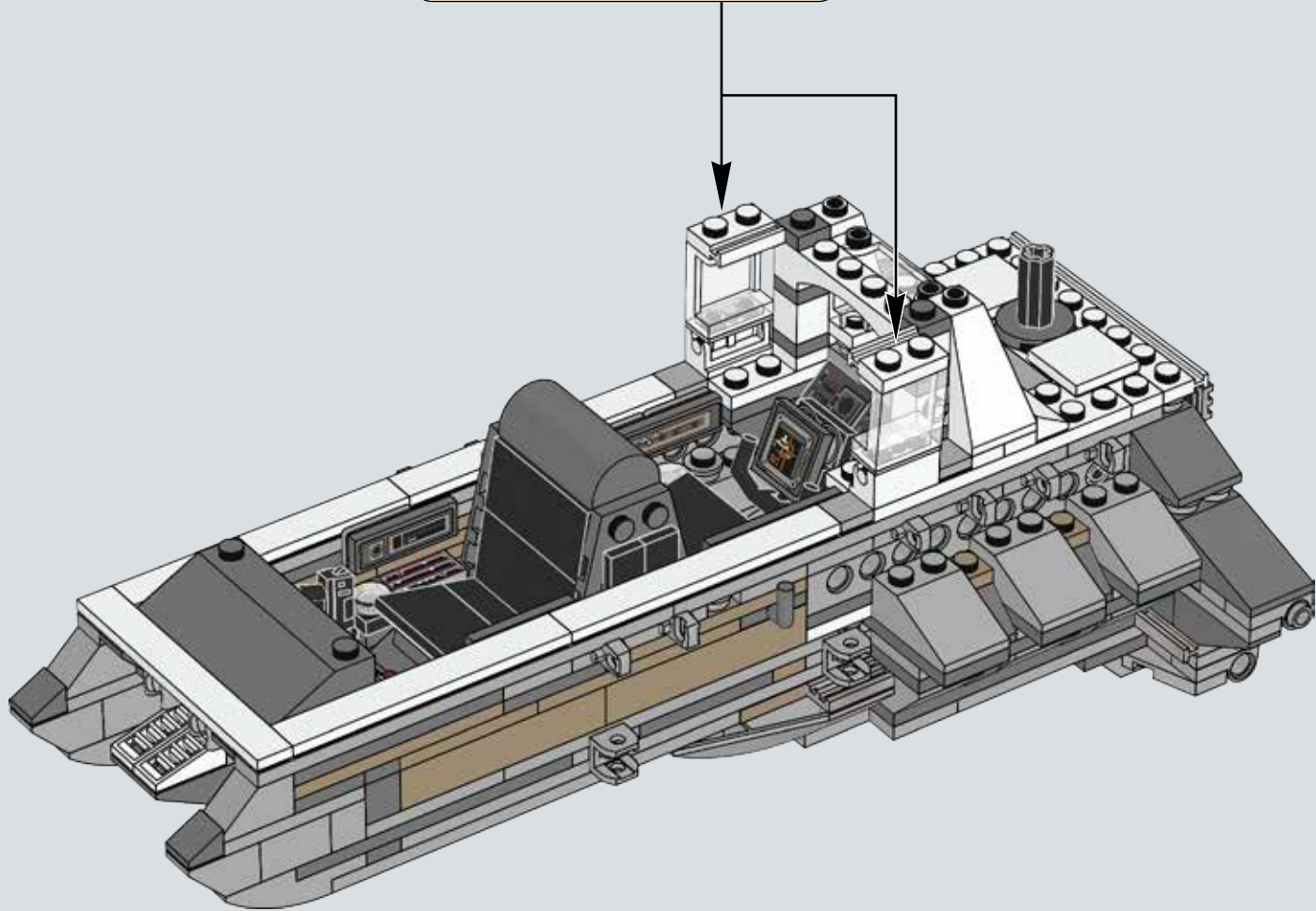
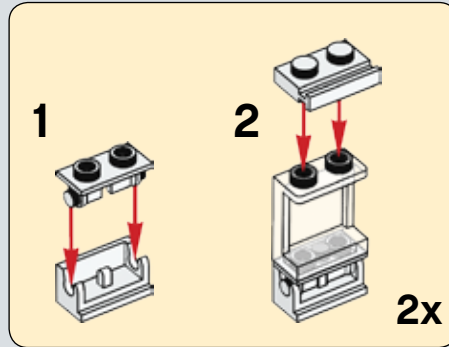

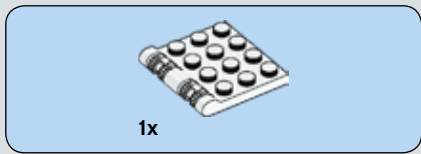

102

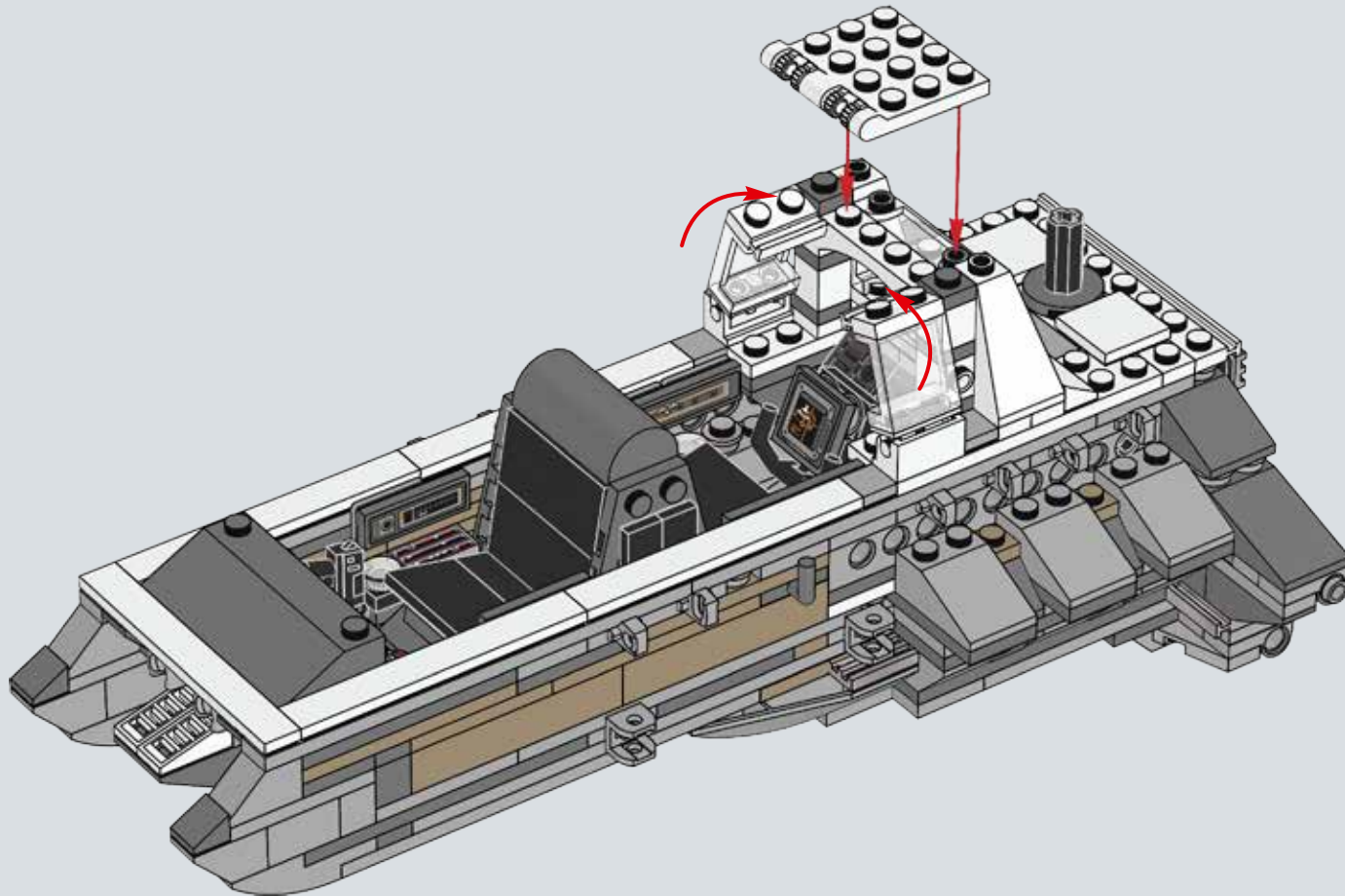

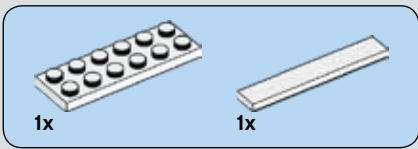

103

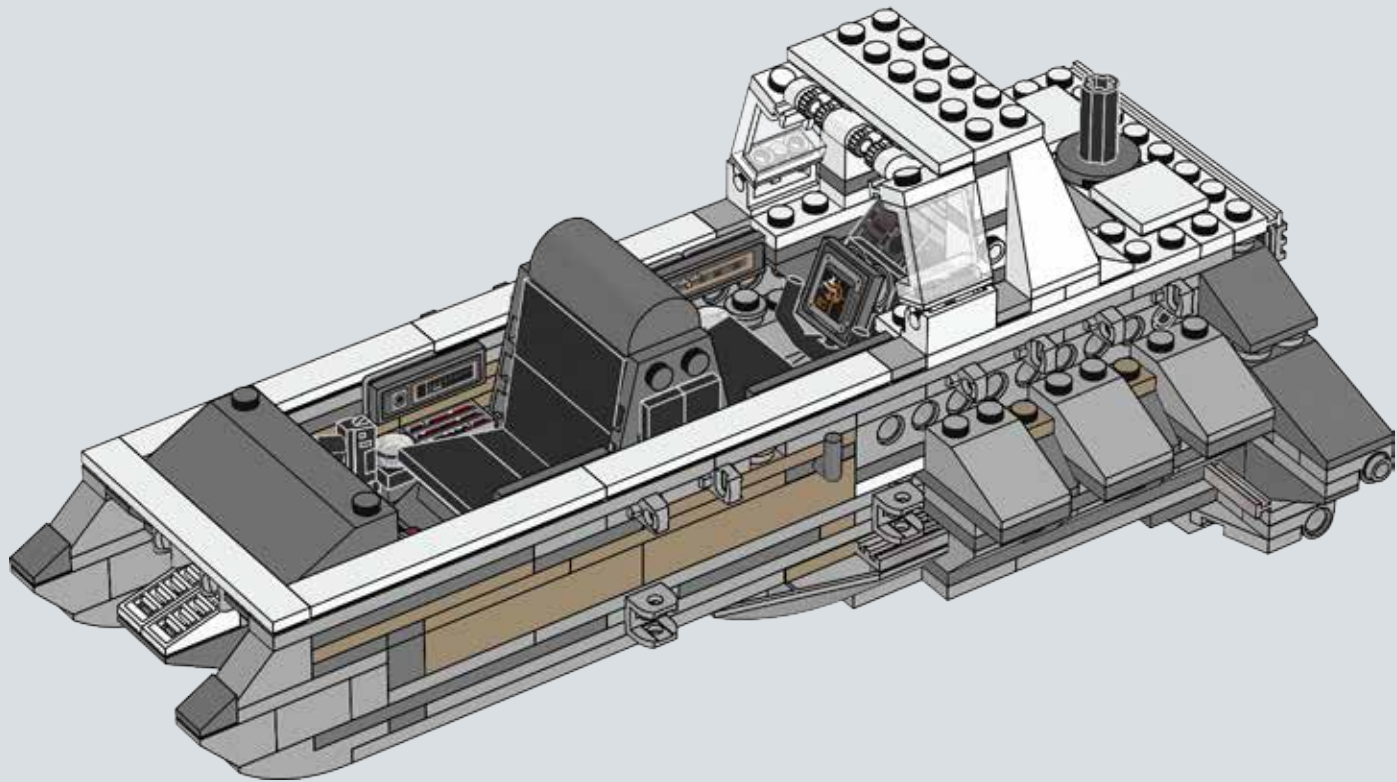

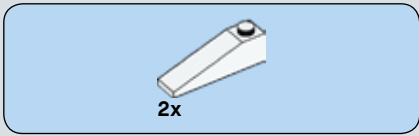

104

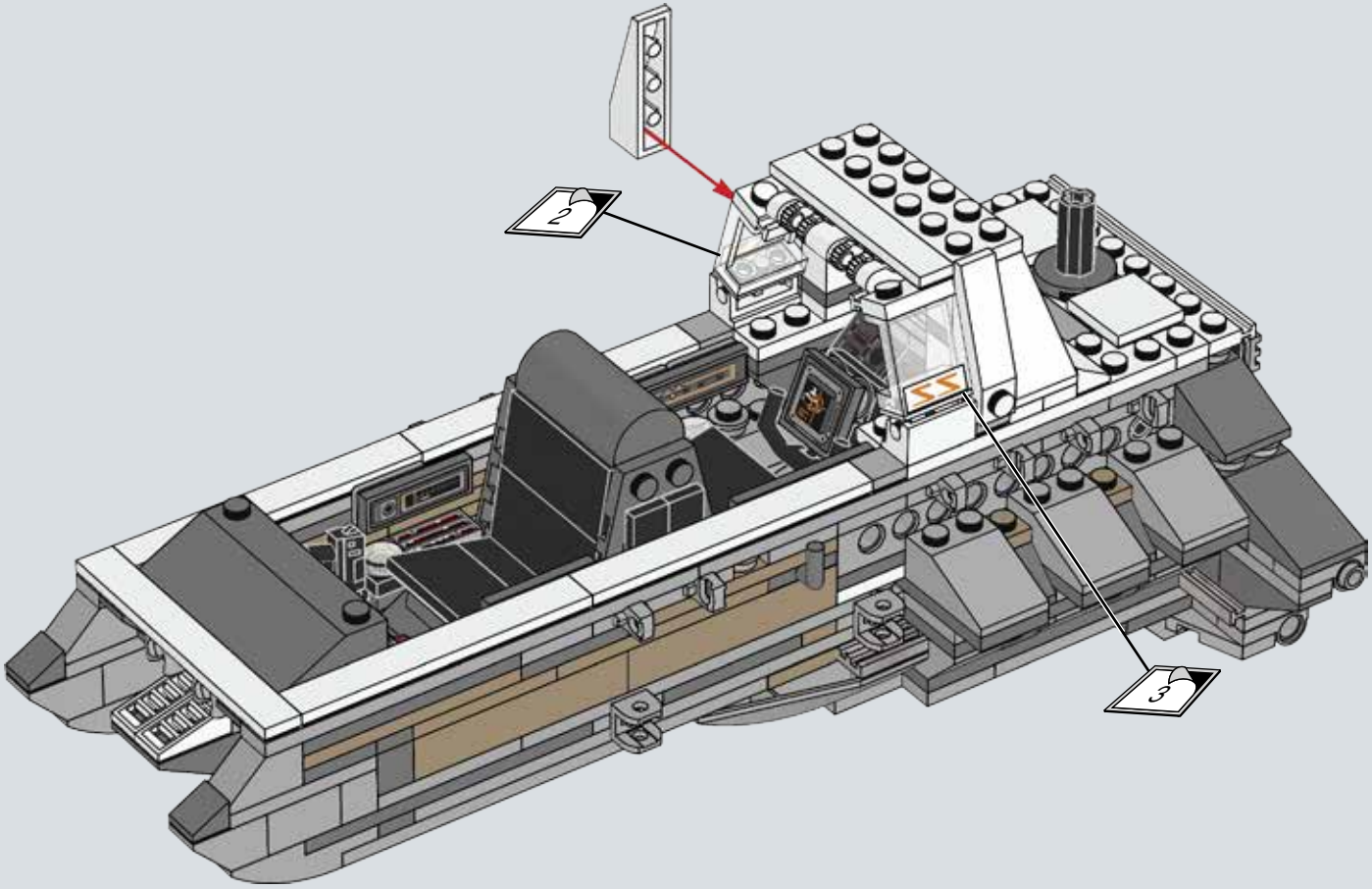

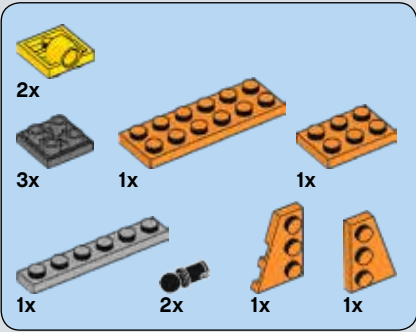

105

1



2

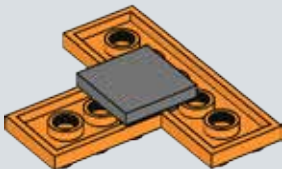

3

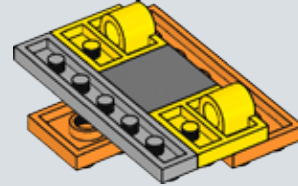

4

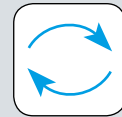
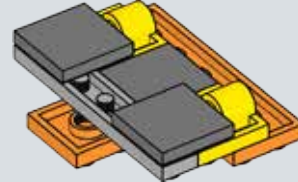

5

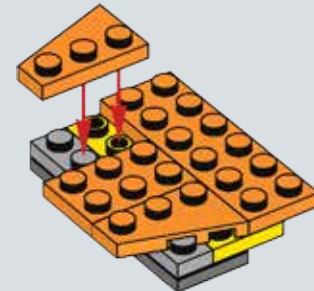

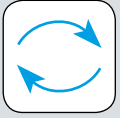

6

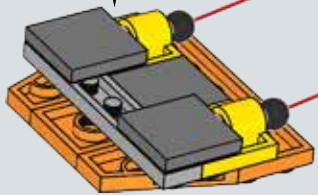
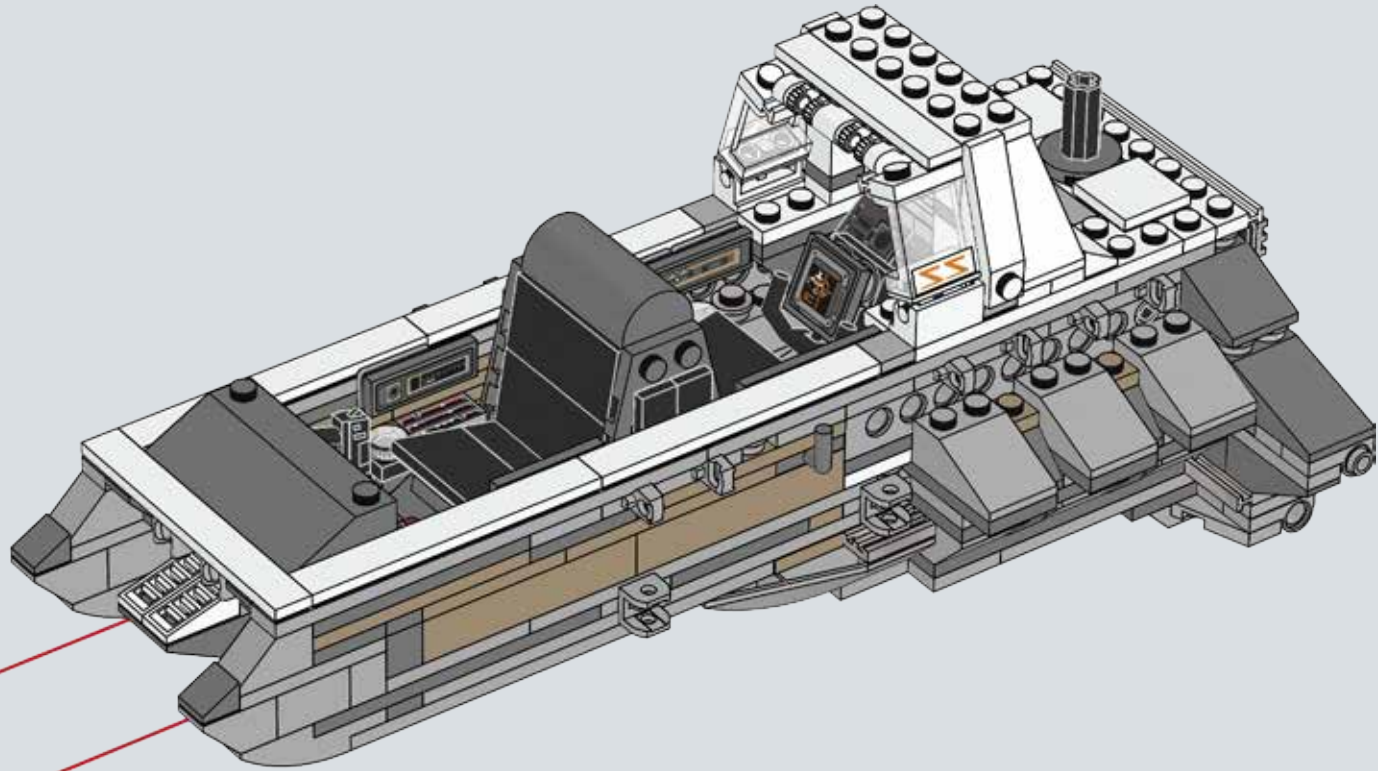
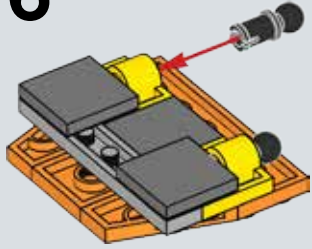

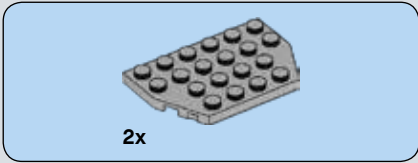

106

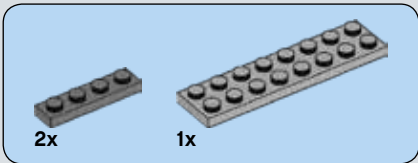
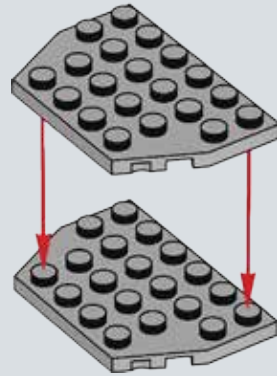

107

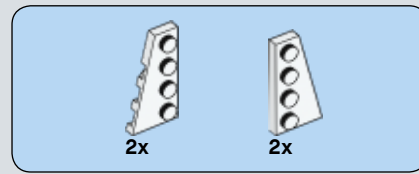
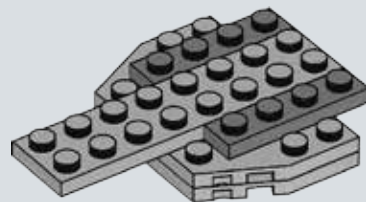

108

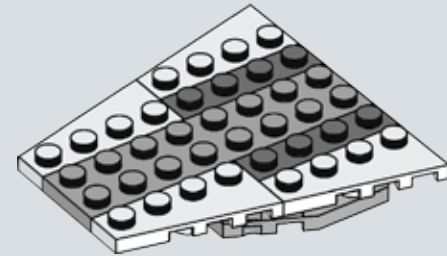

109

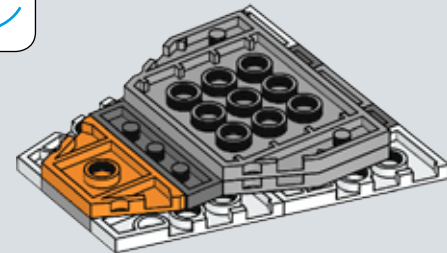
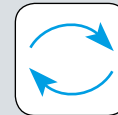



1x

110

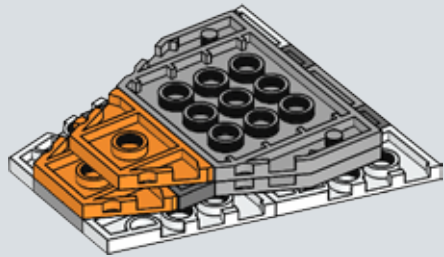

1x

112

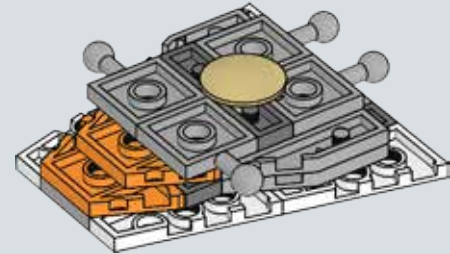

1x



4x

111

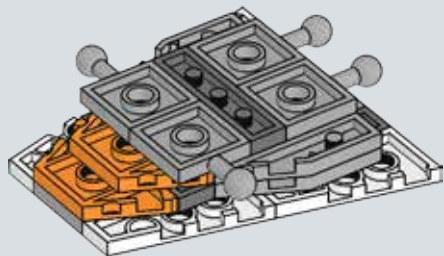

1x



6x

113

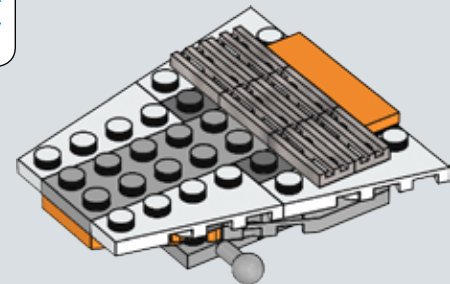
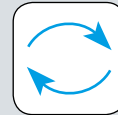

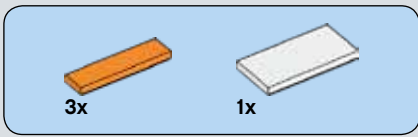

114

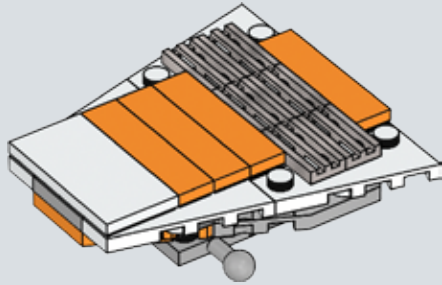

115

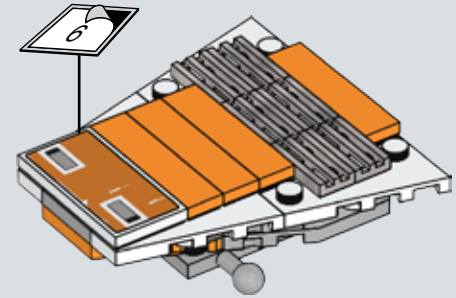

116

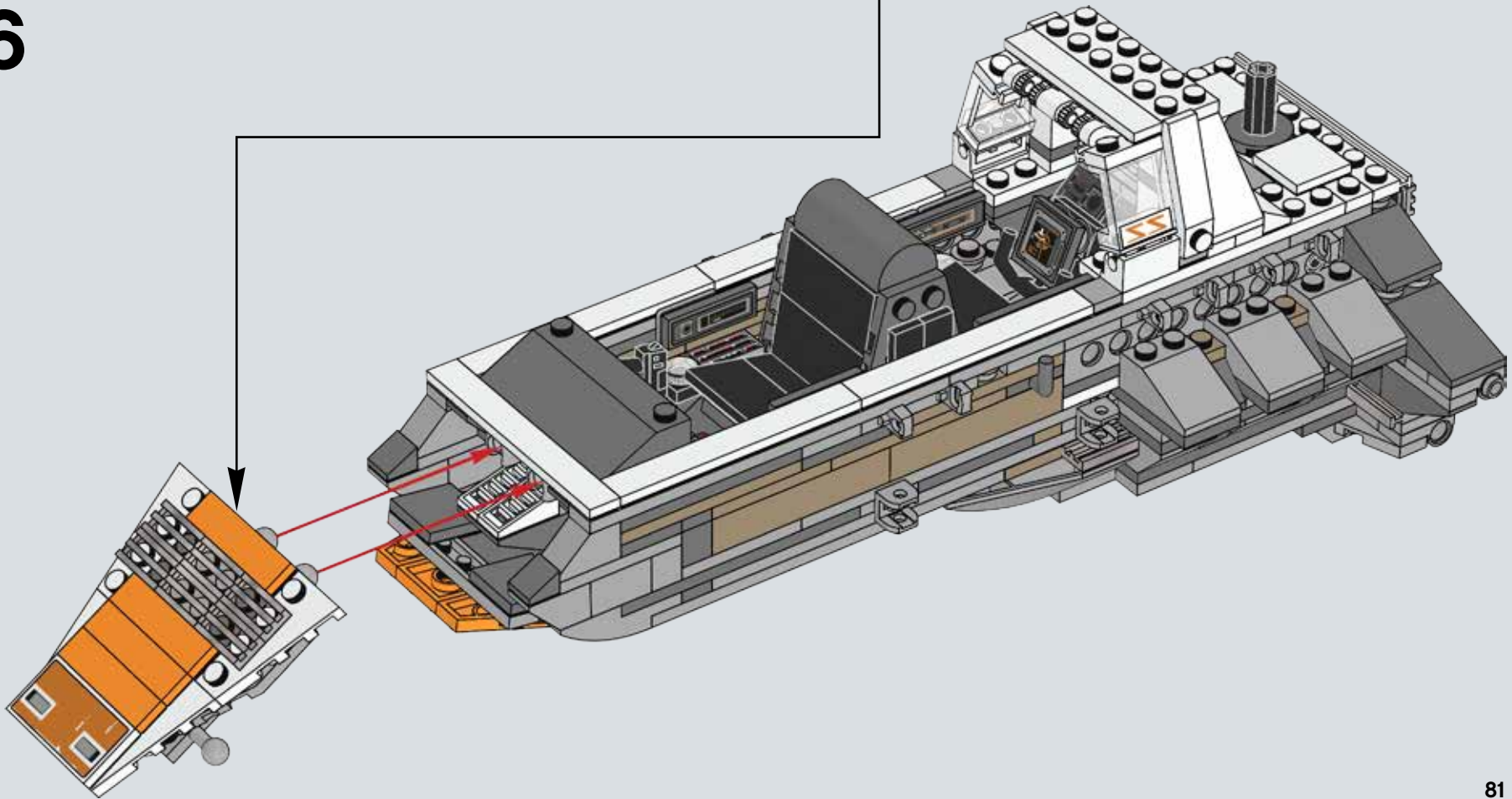

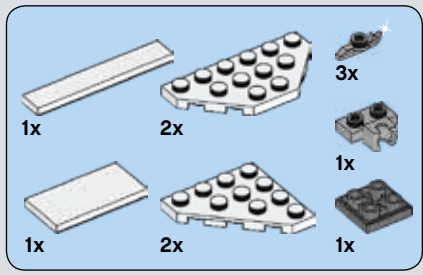

117

1

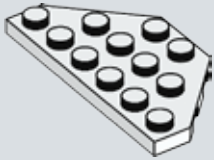

2

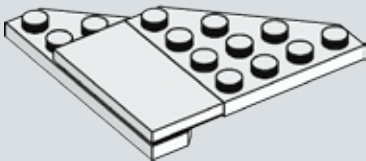

3

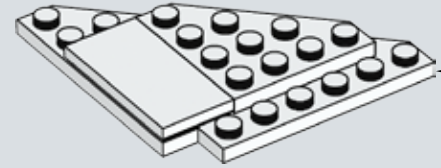

4

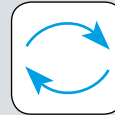
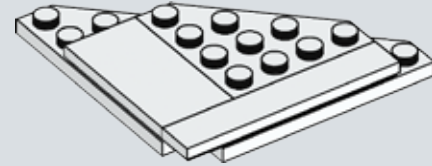

5

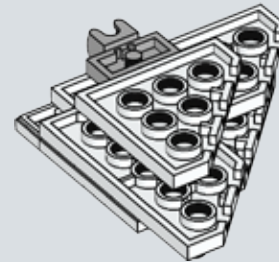

6

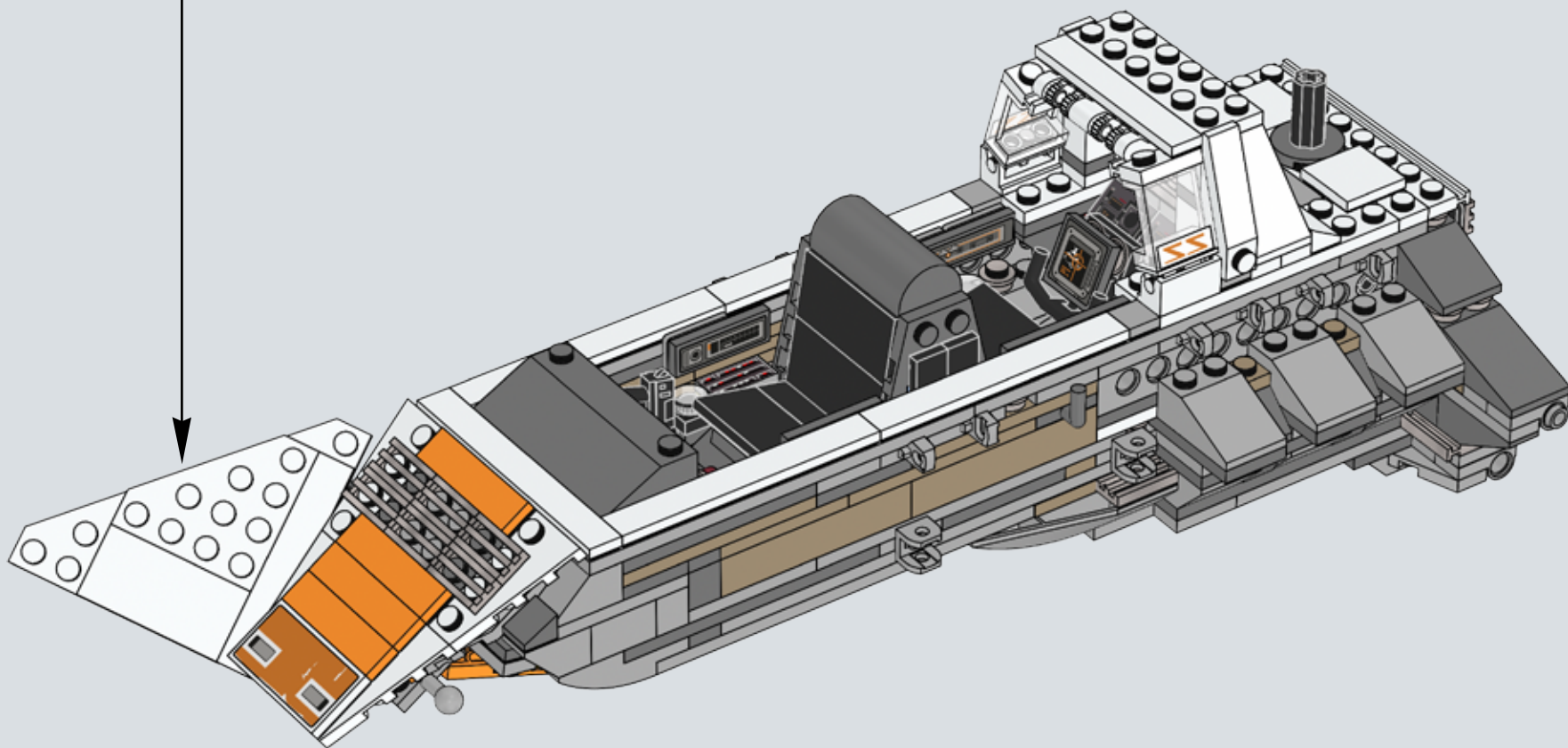
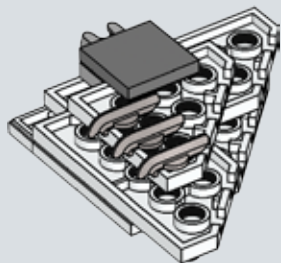

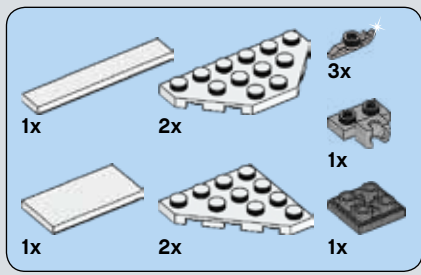

118

1

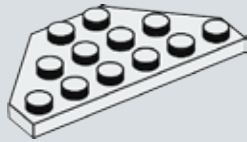

2

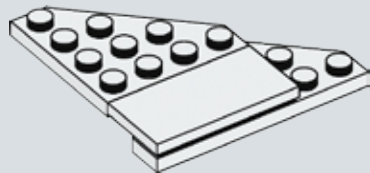

3

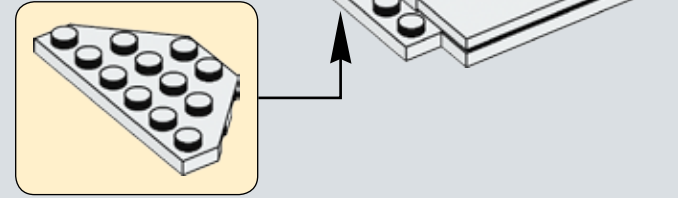

4

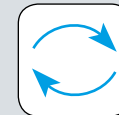
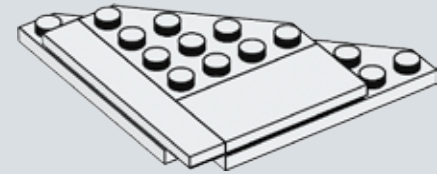

5

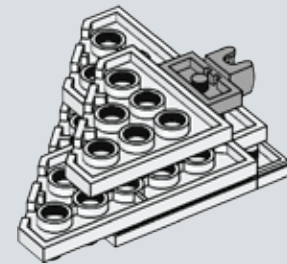

6

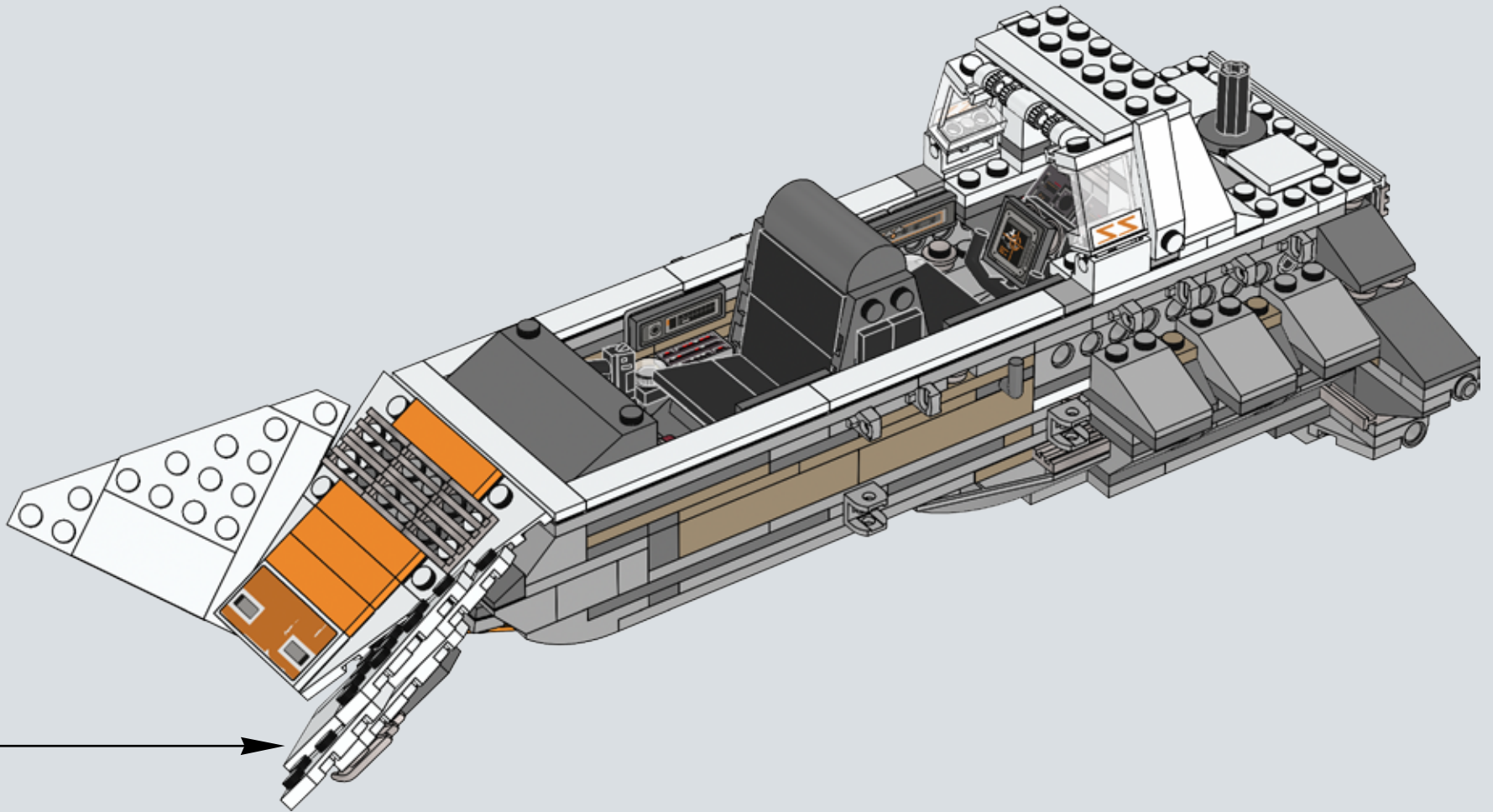
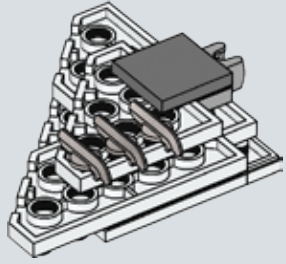



+

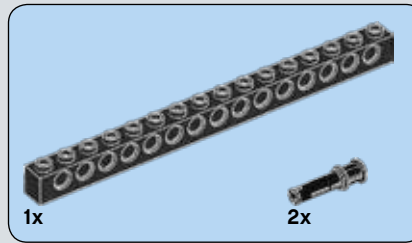
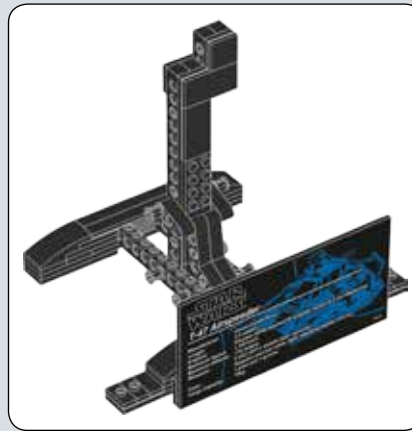
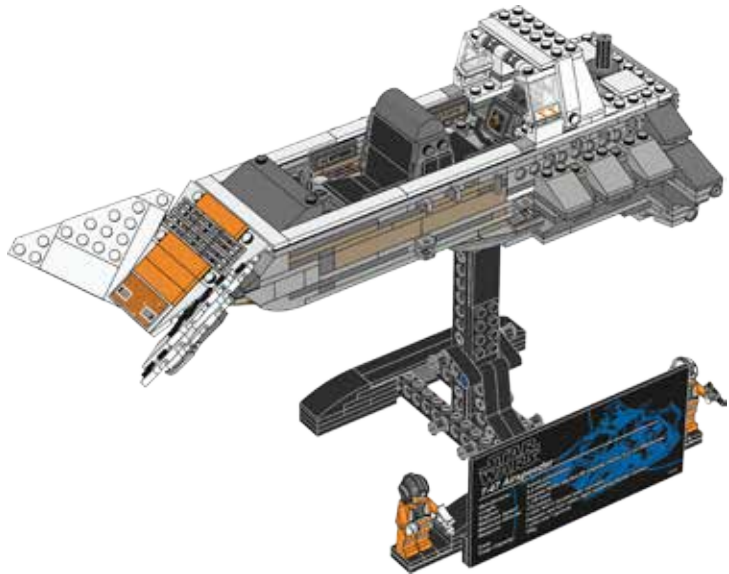

119

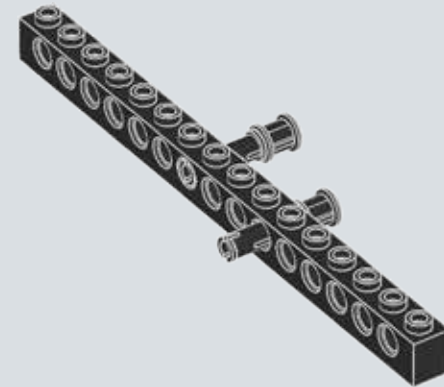

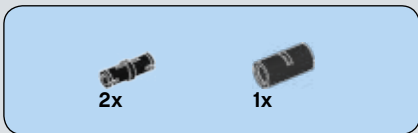

120

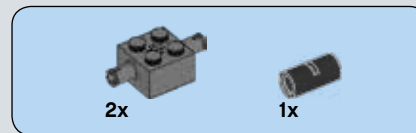
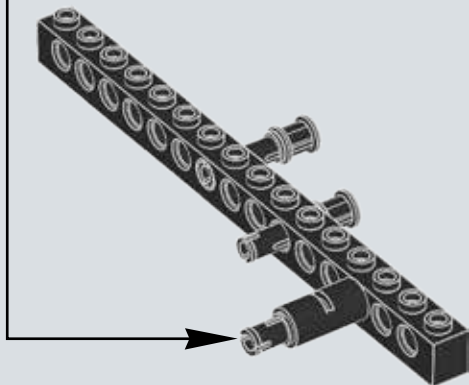
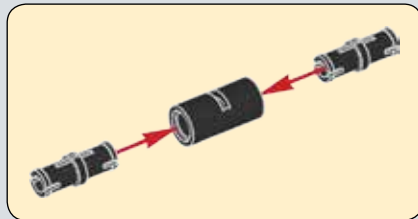

121

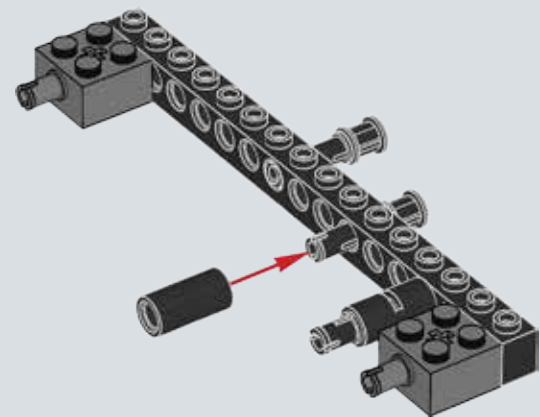

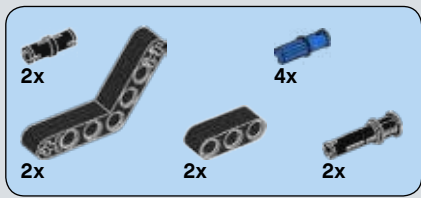

122

1



2



3

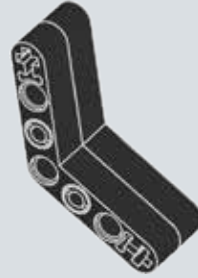

4

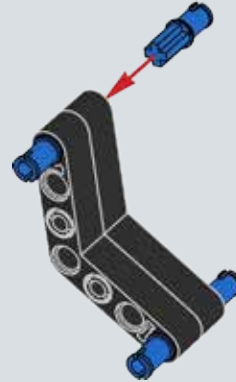

5

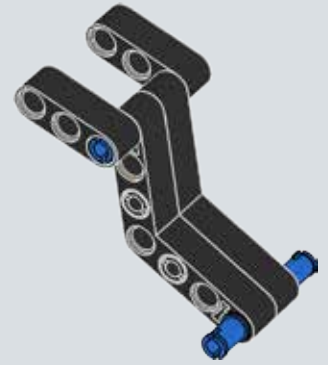

6

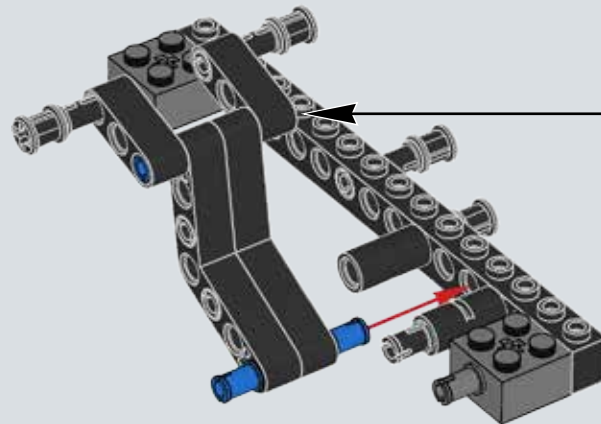
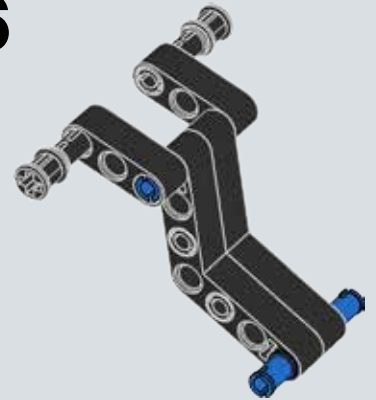

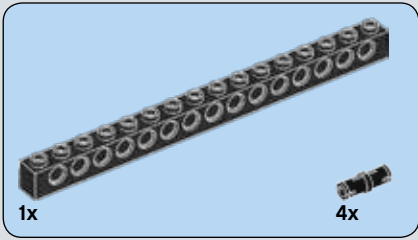
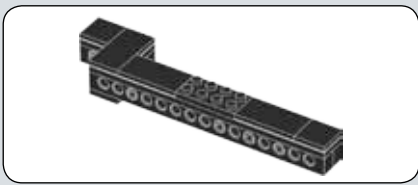

123

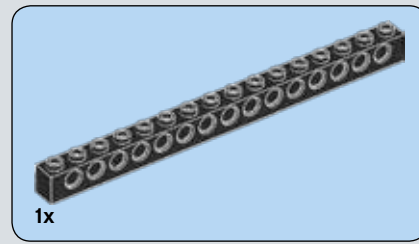
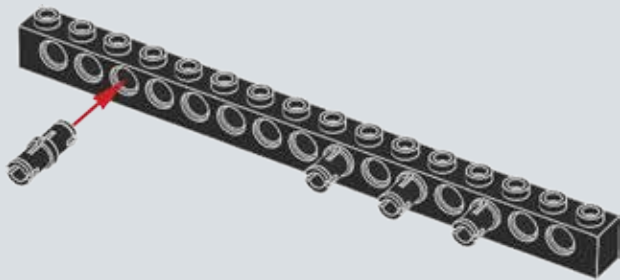

124

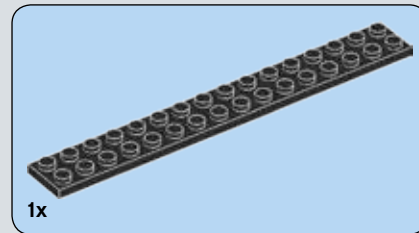
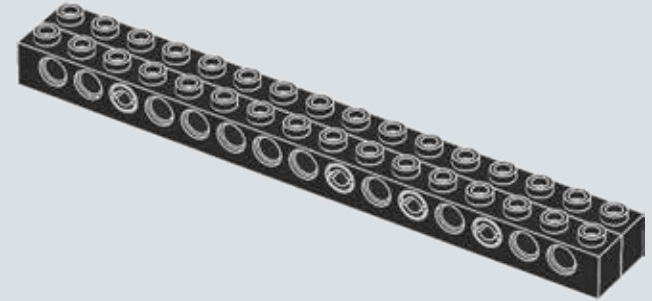

125

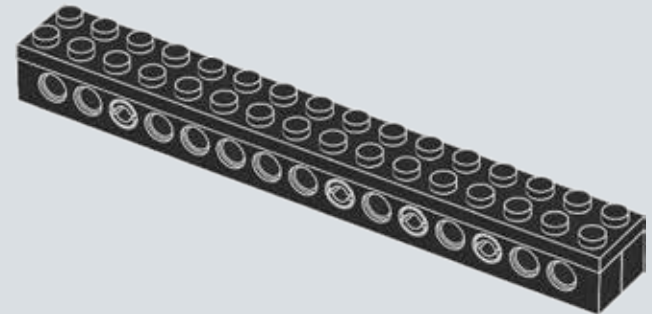

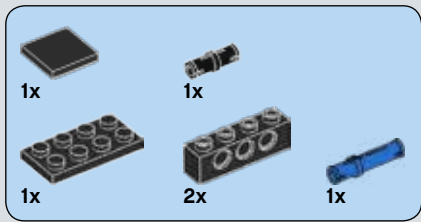

126

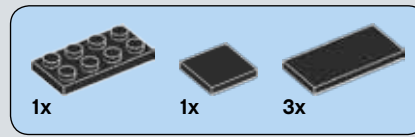
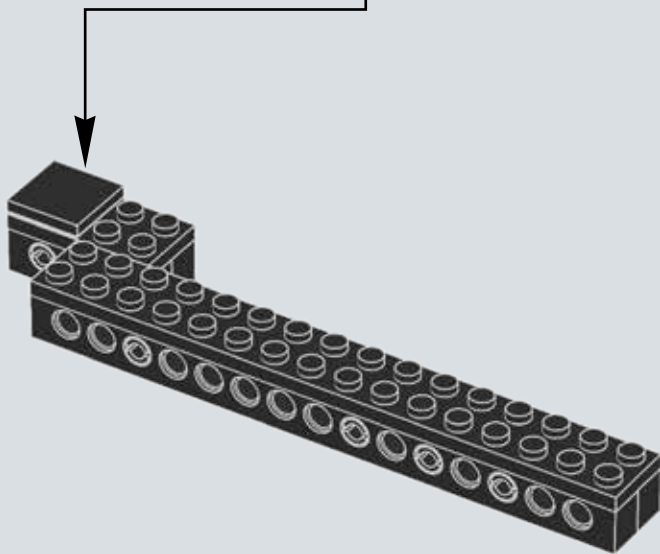
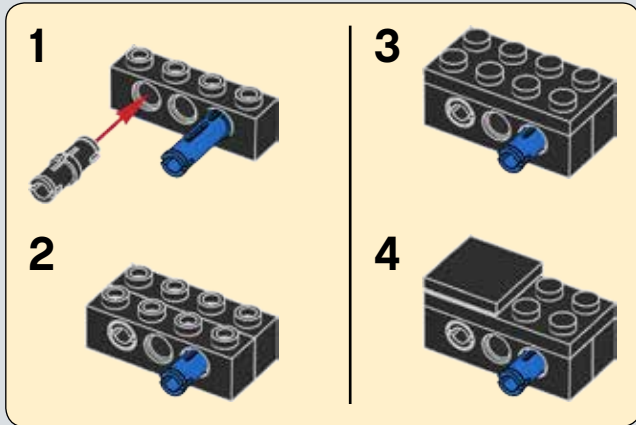

127

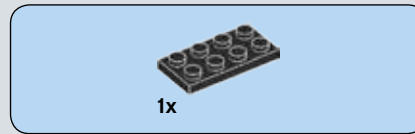
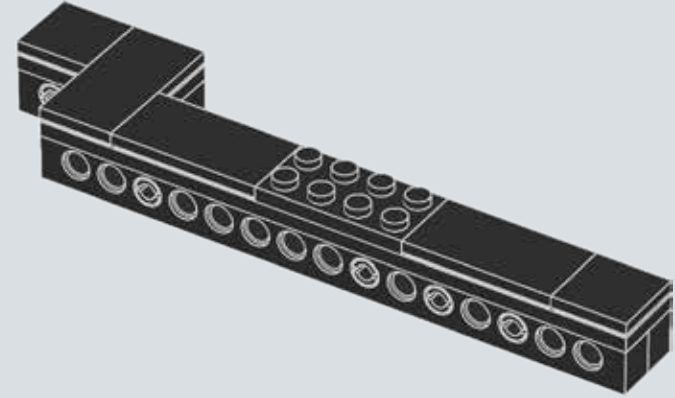

128

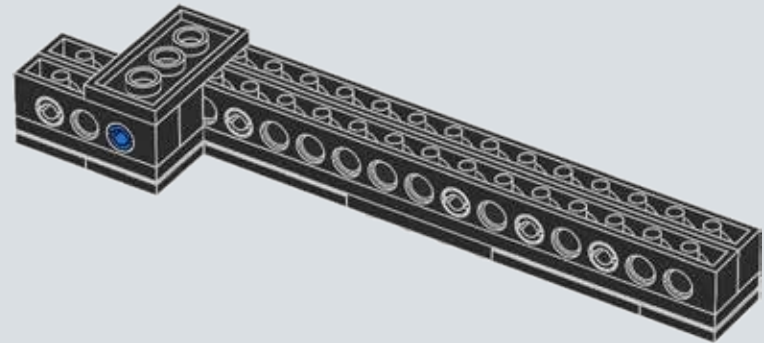
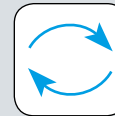

129

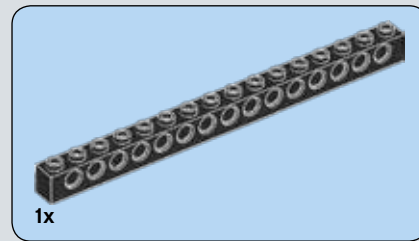
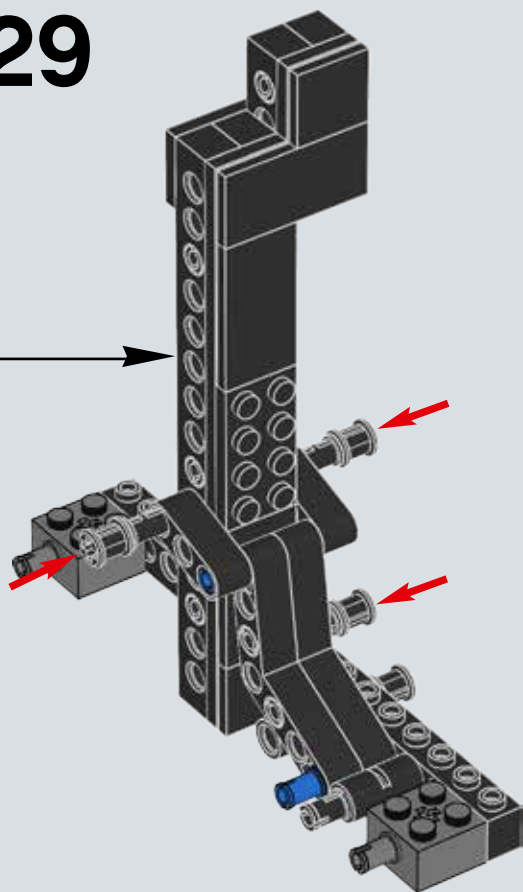

130

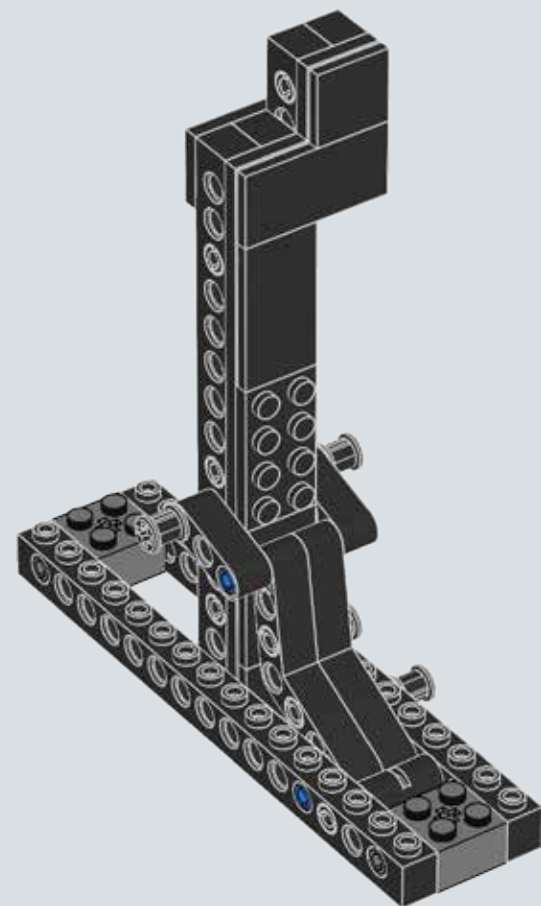



2x

131

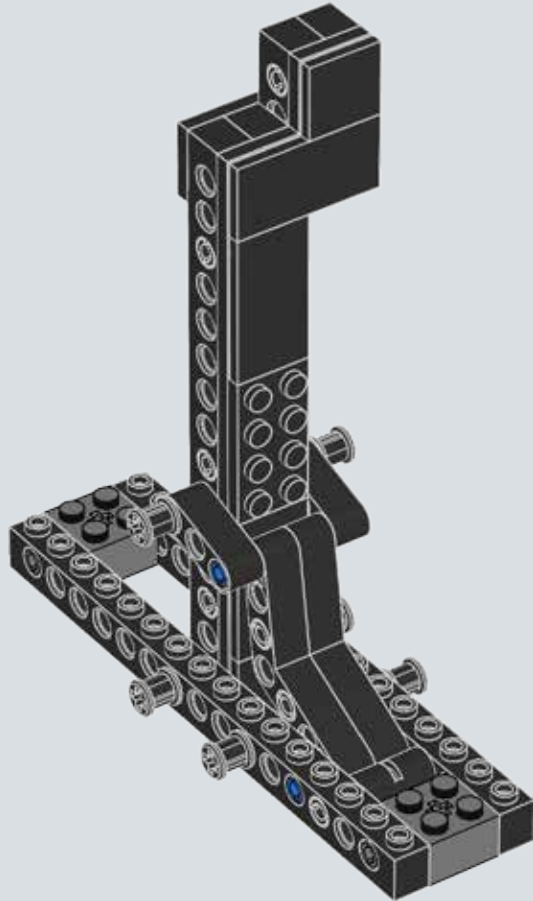

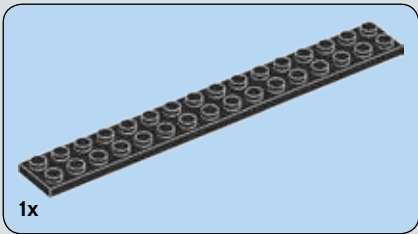
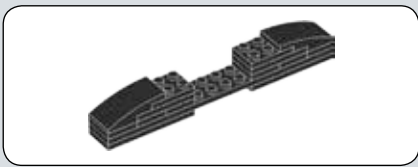

132

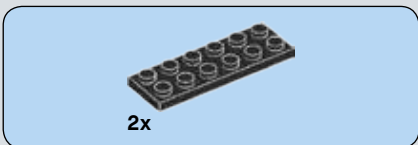
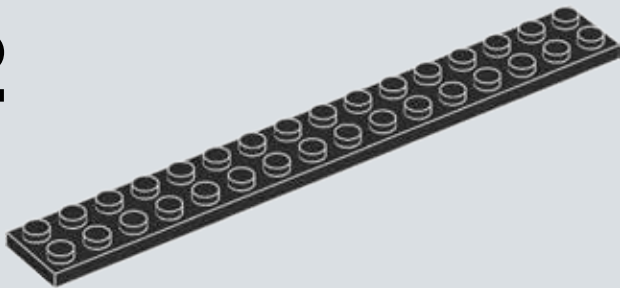

133

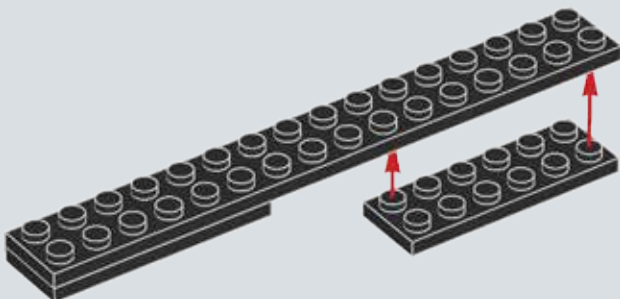

134

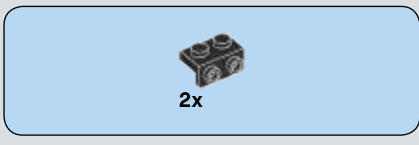
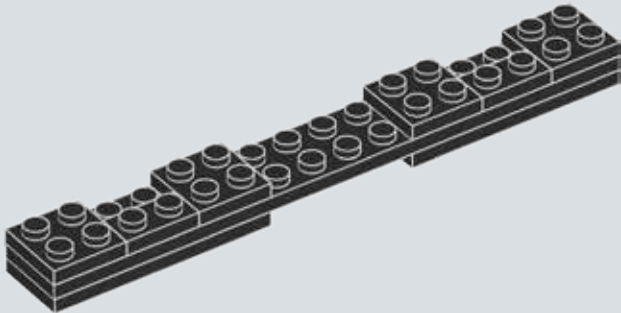

135

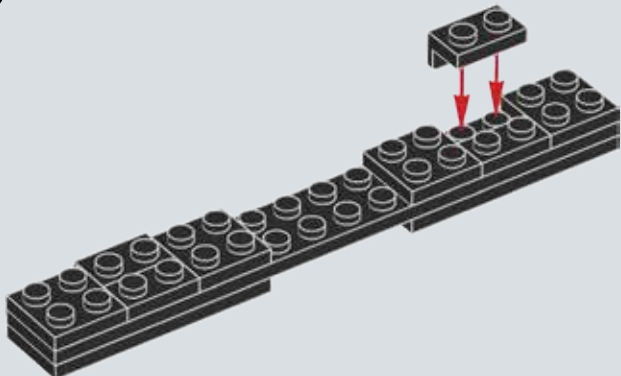

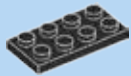

2x

136

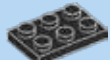
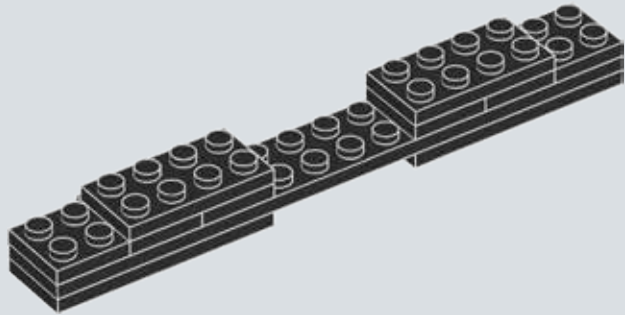

2x

137

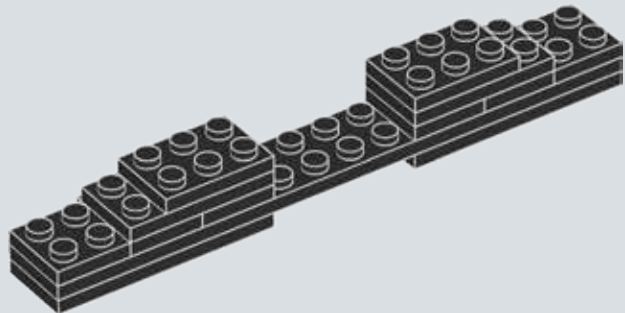

2x

138

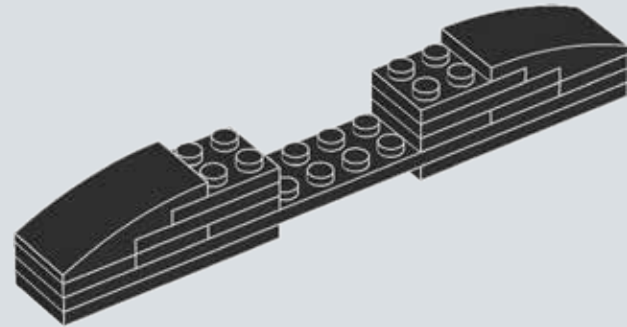

139

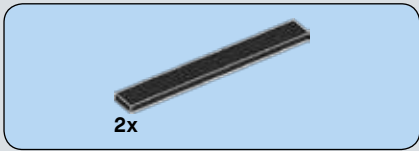
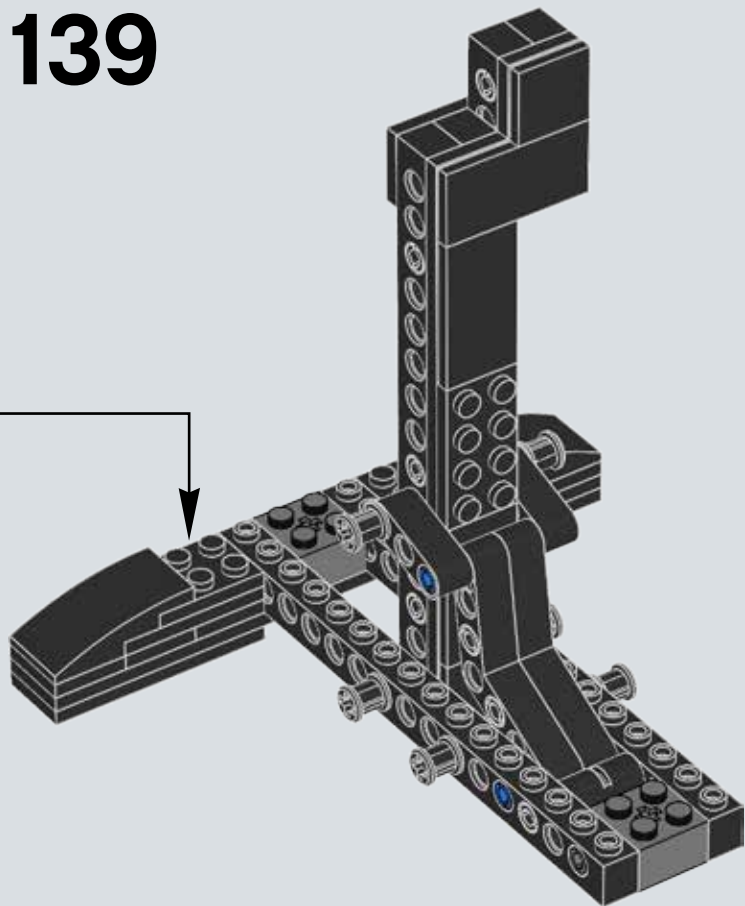

140

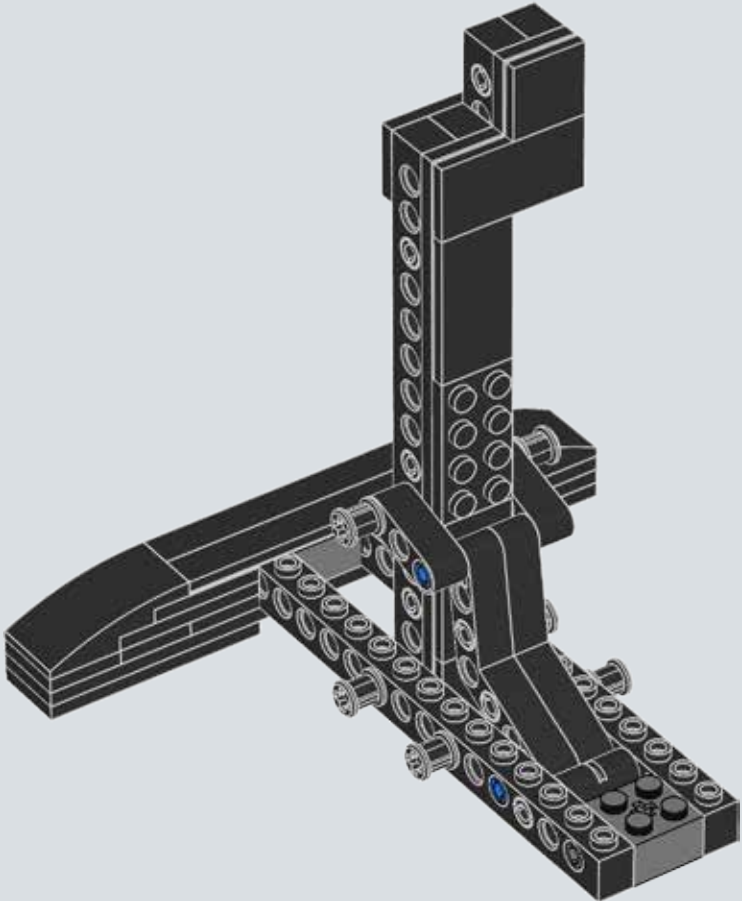

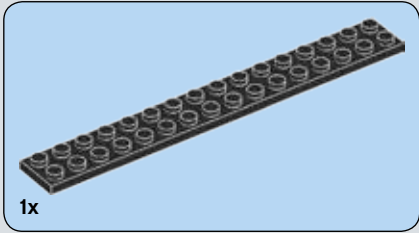
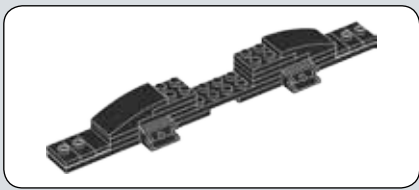

141

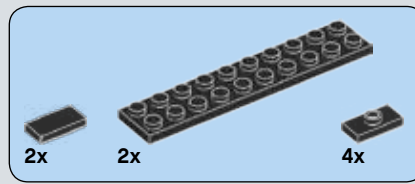
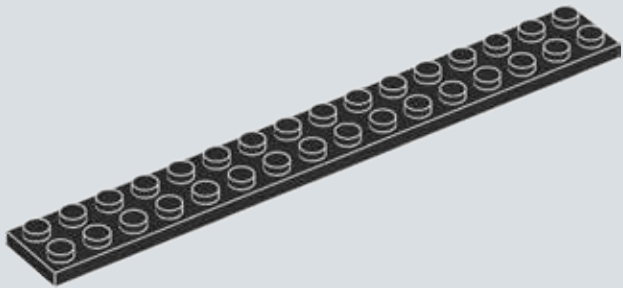

142

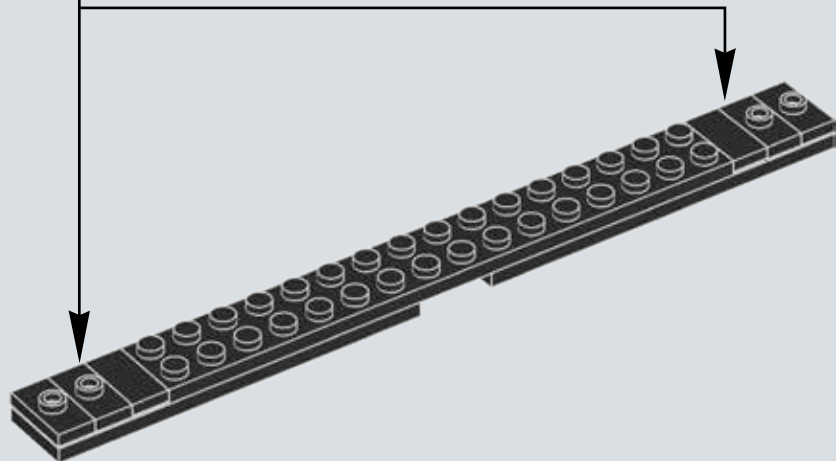
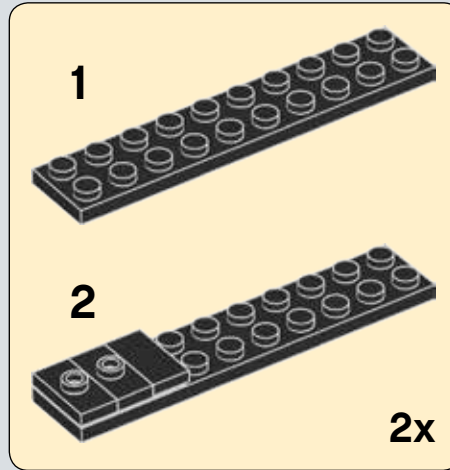



143

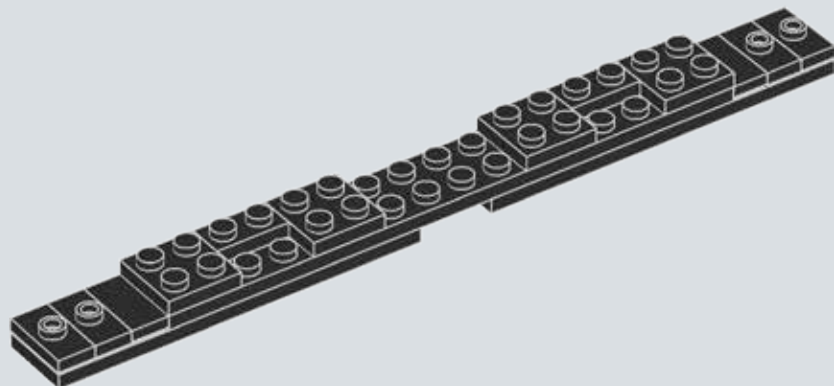

144

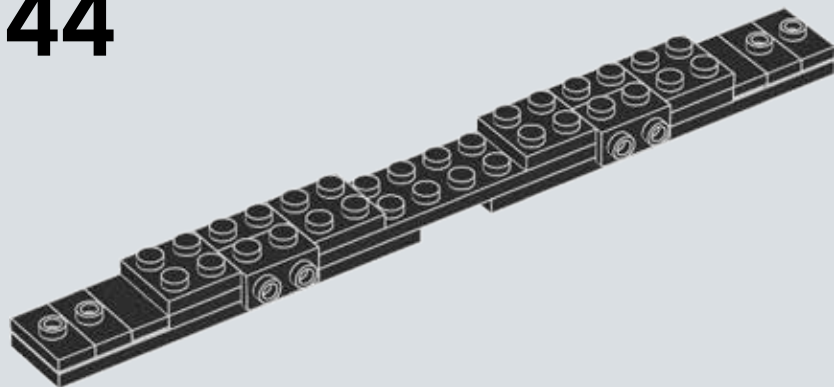

145

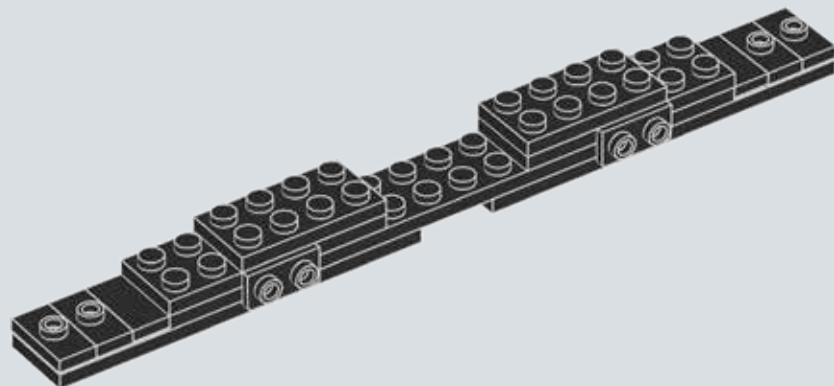

146

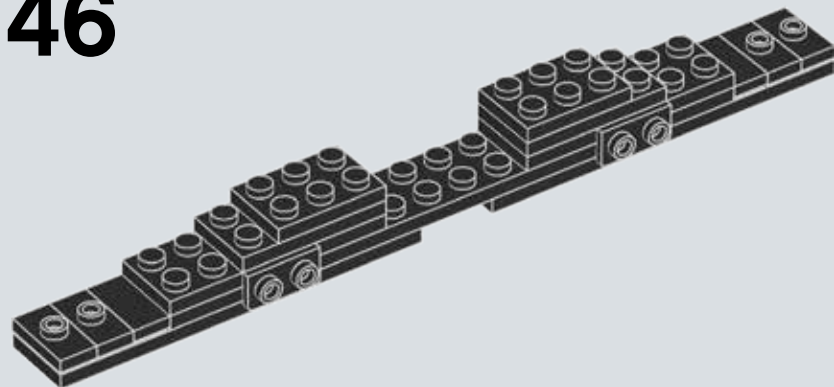

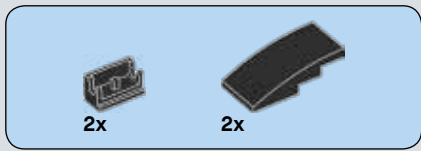

147

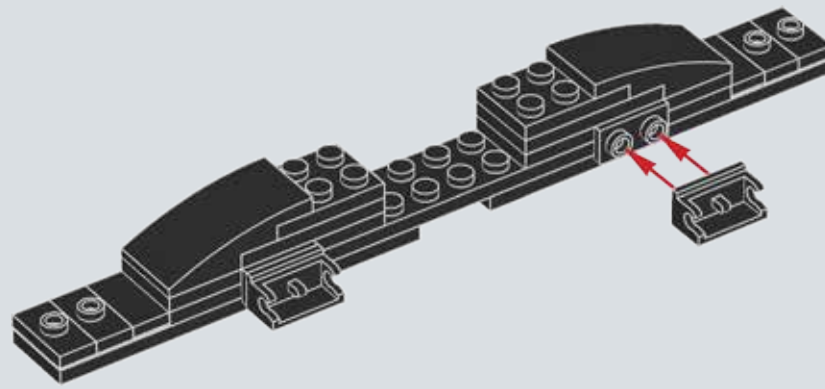

148

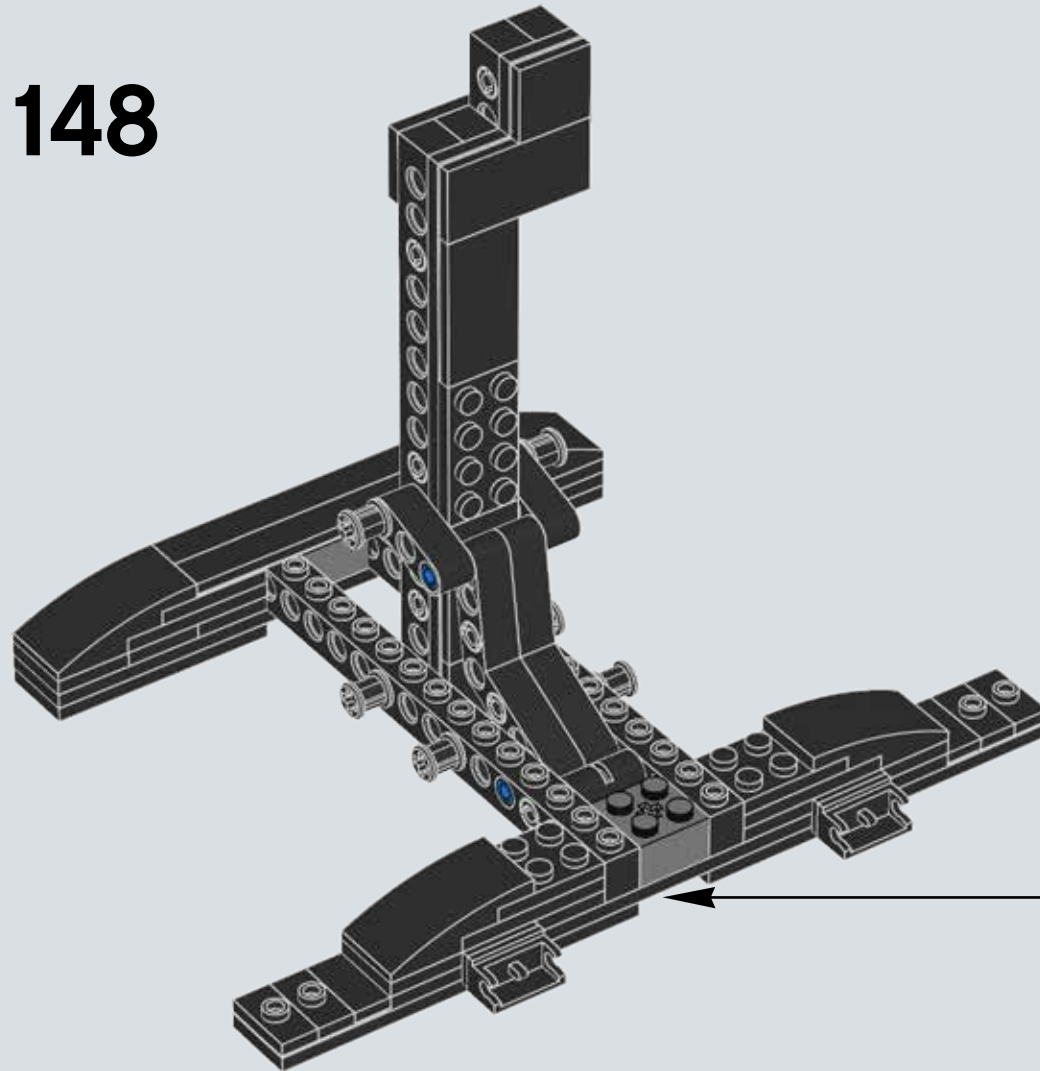

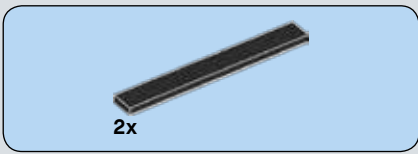

149

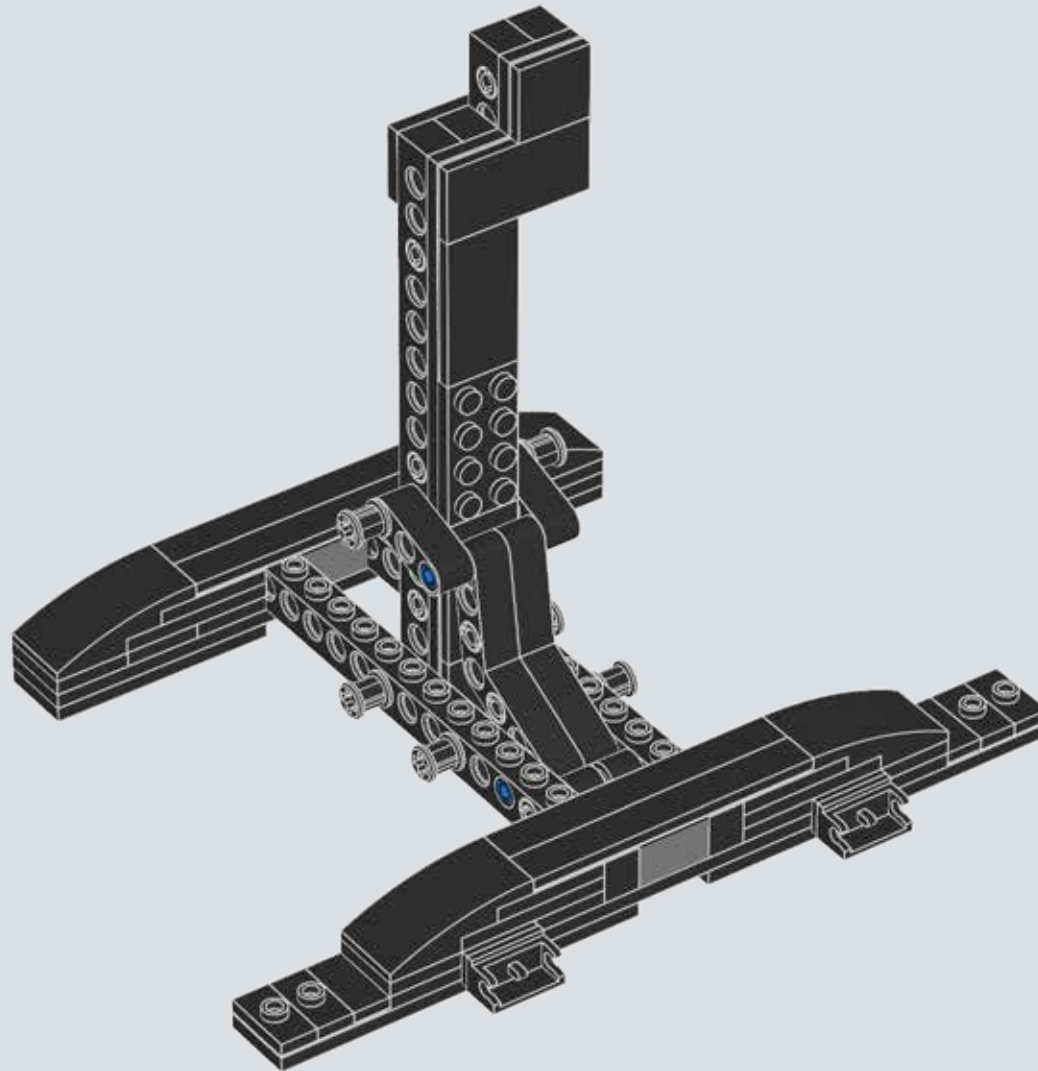

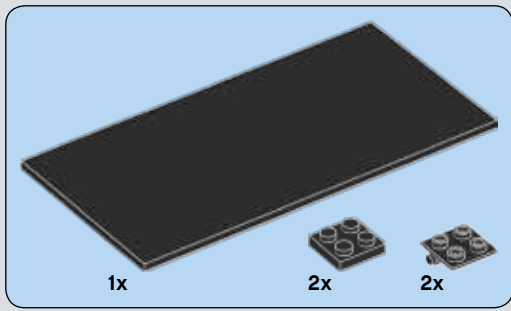

150

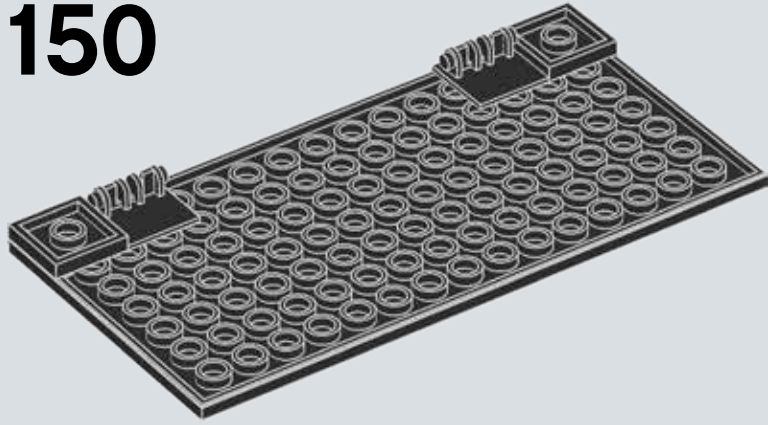

151

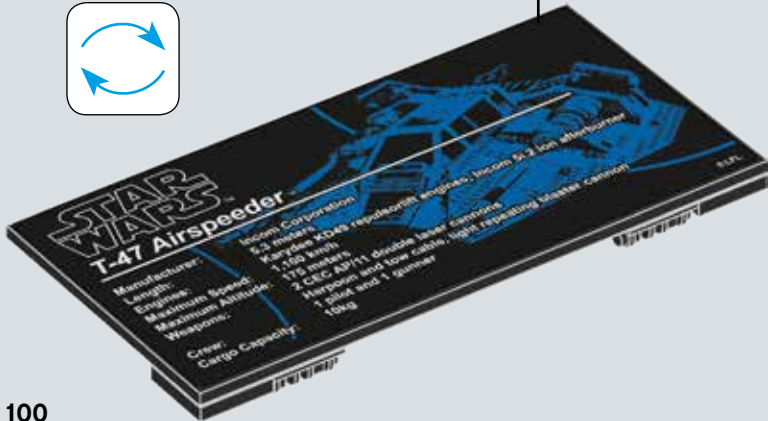
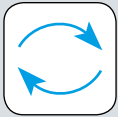

152

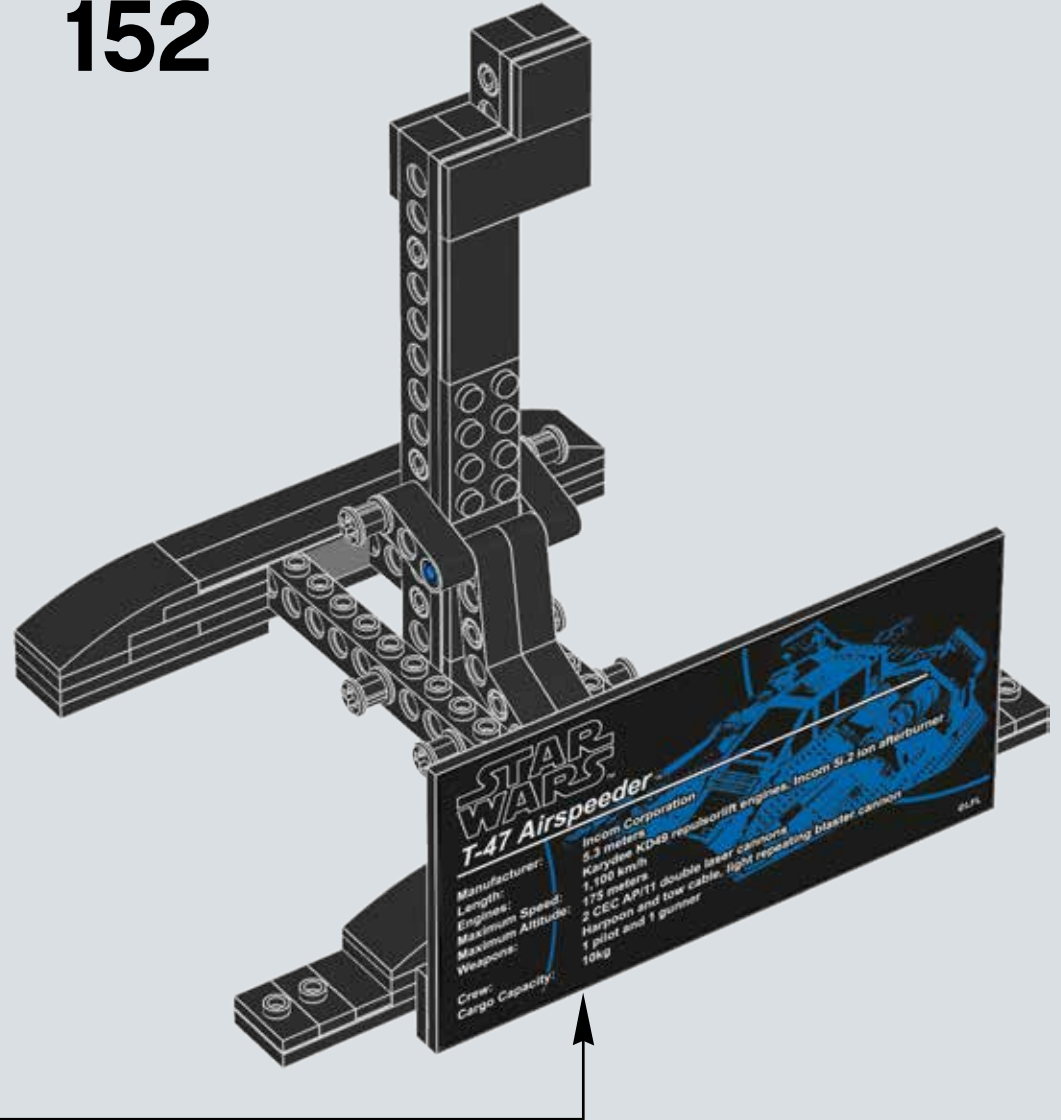

153

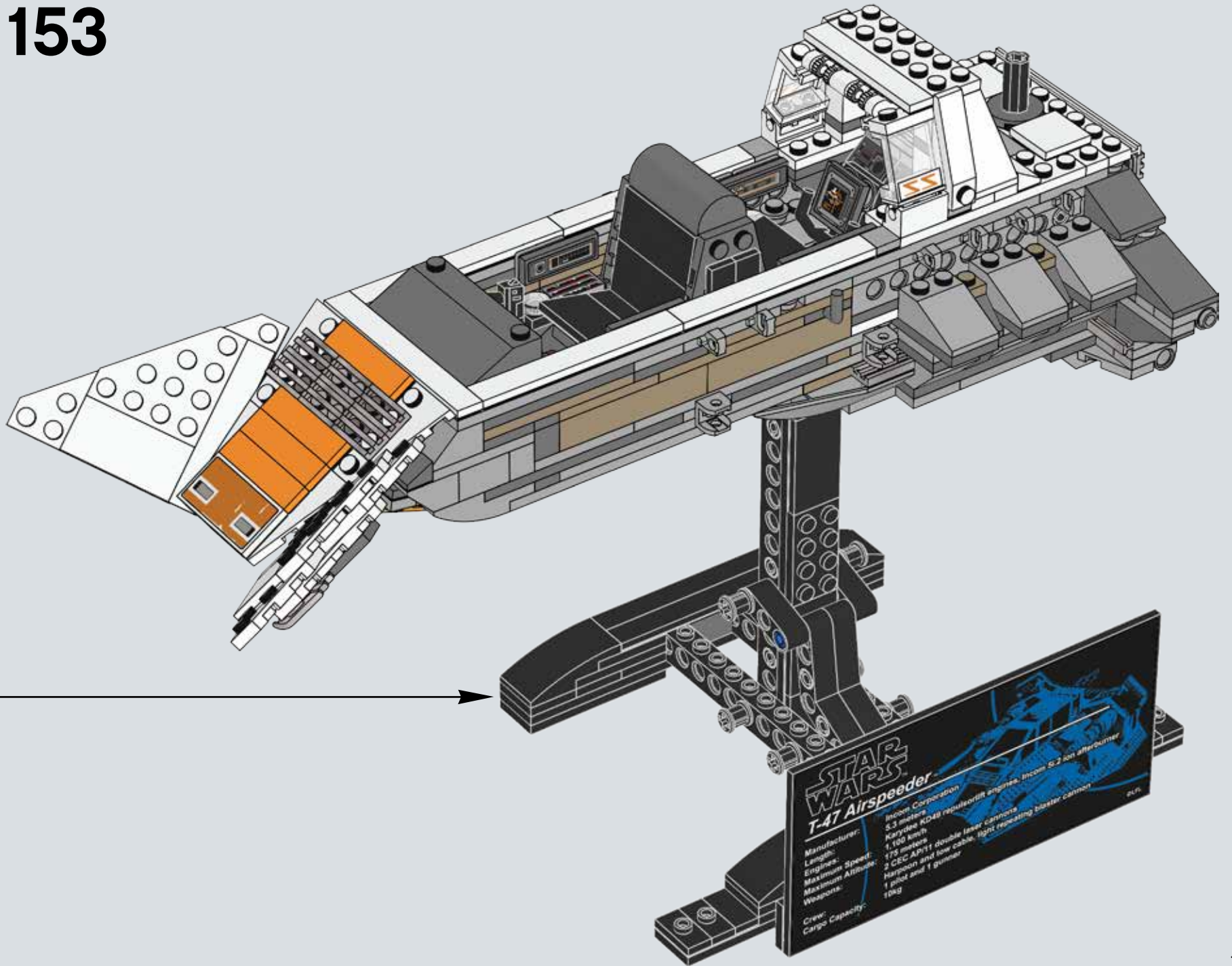

154

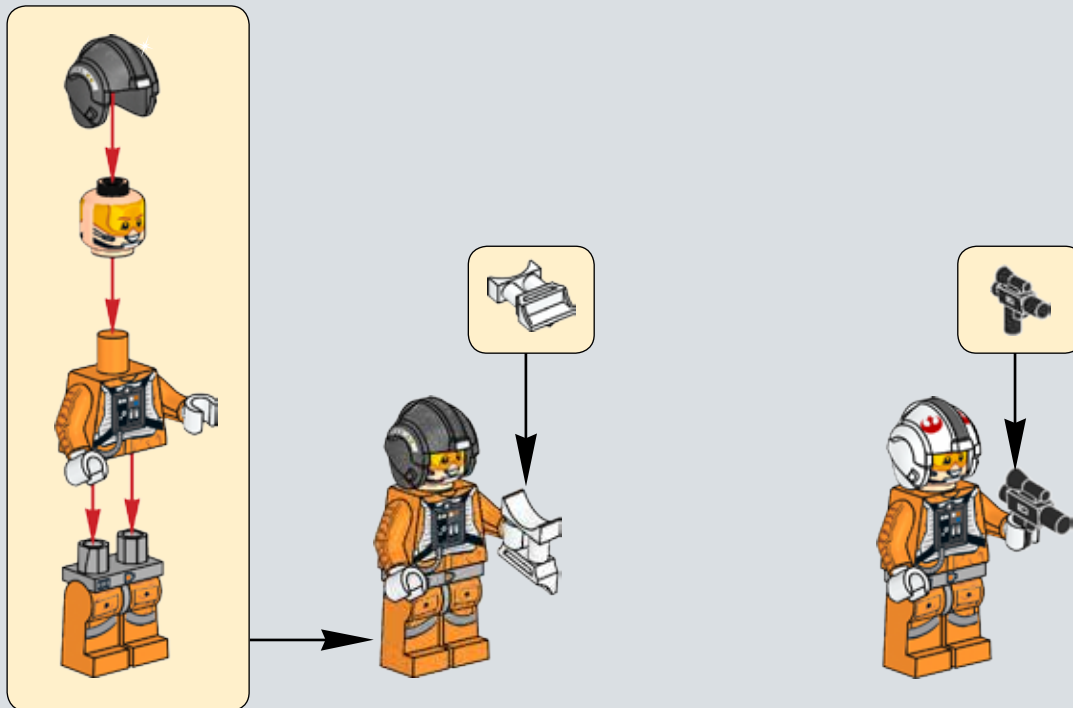

155

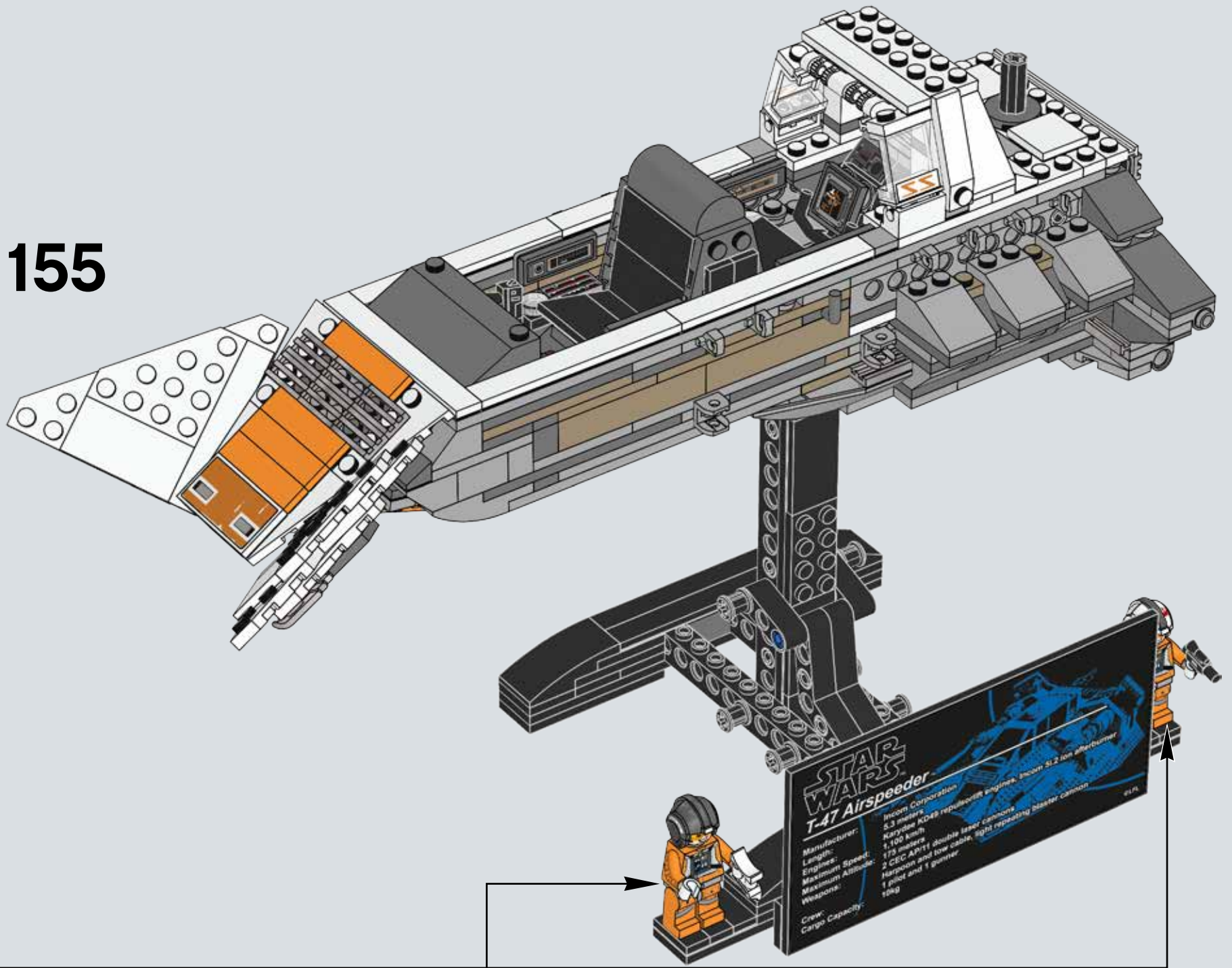

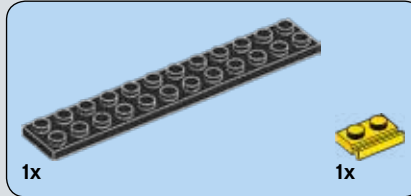
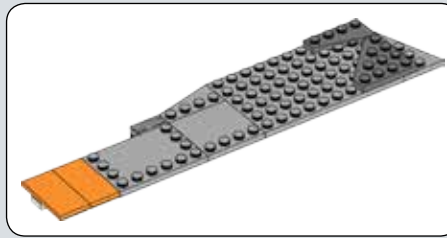
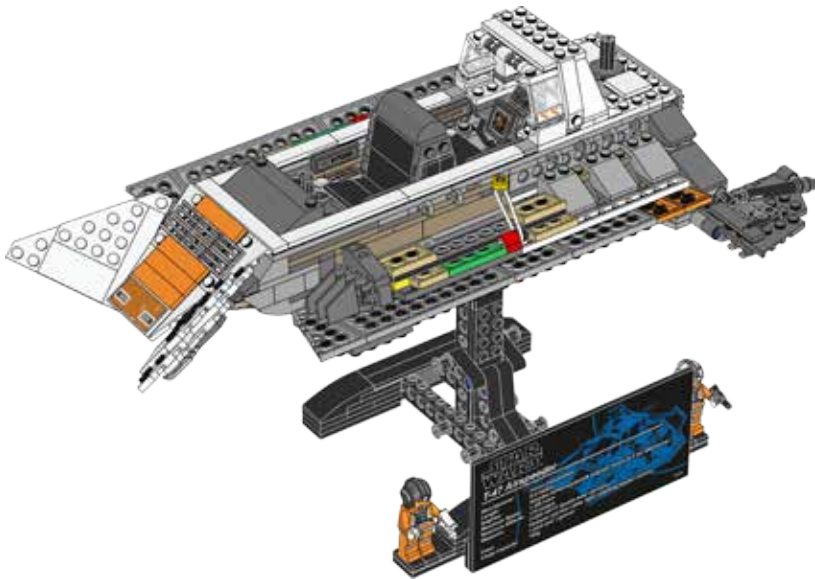

156

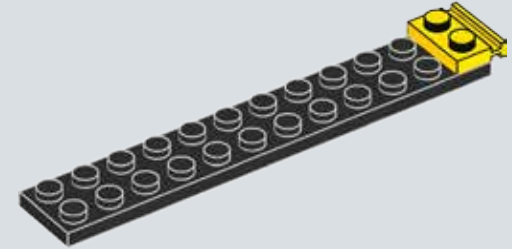

157

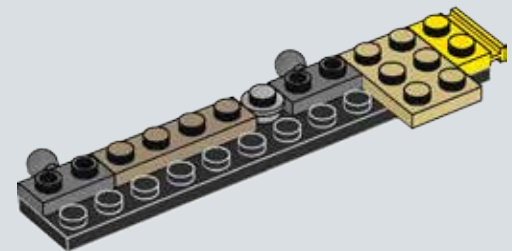



158

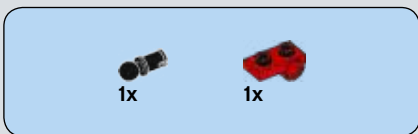
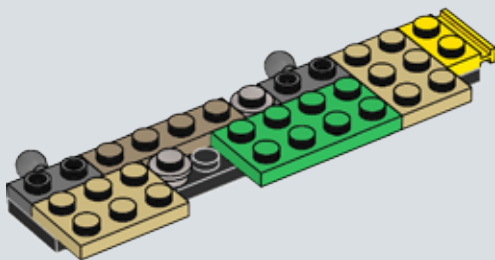

159

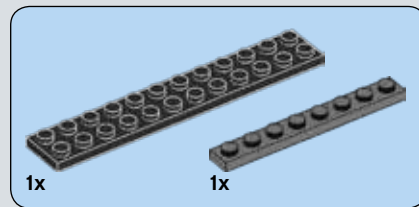
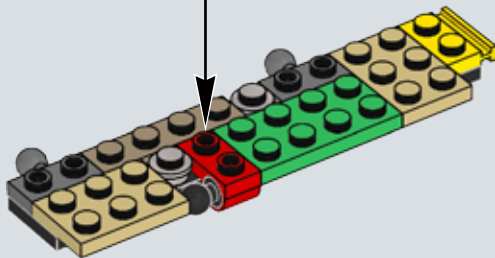
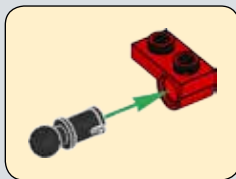

160

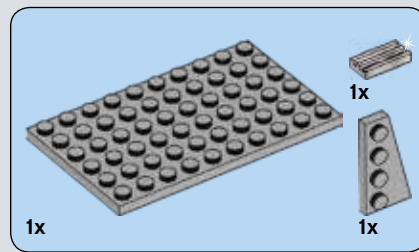
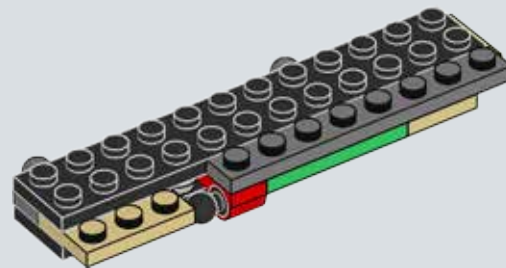

161

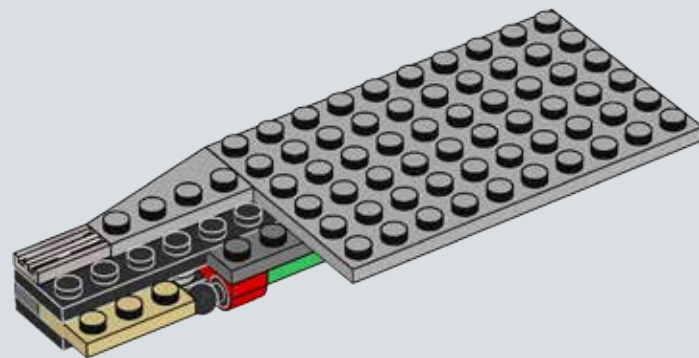

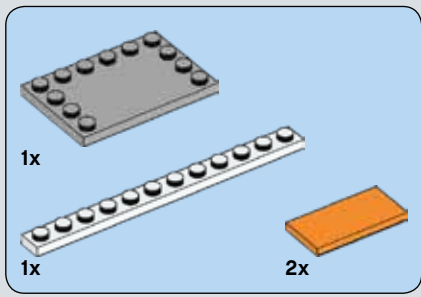

162

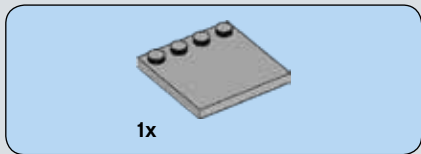
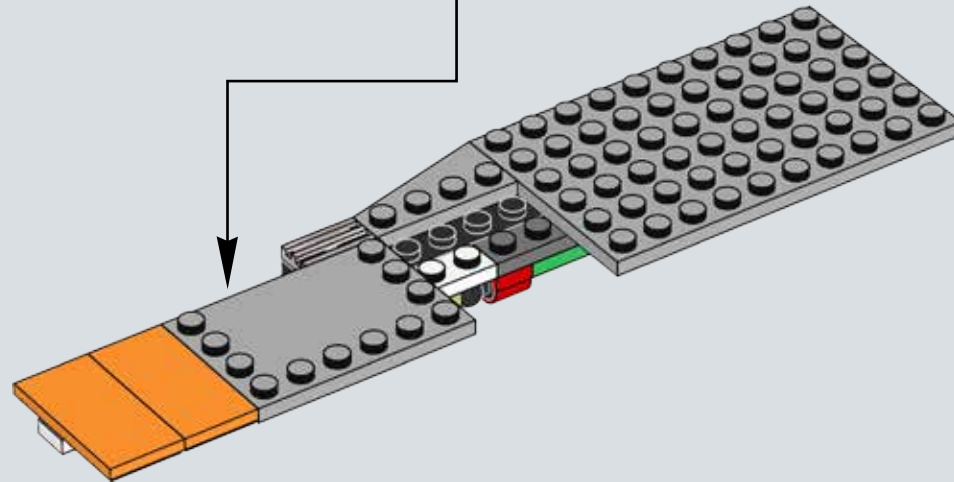
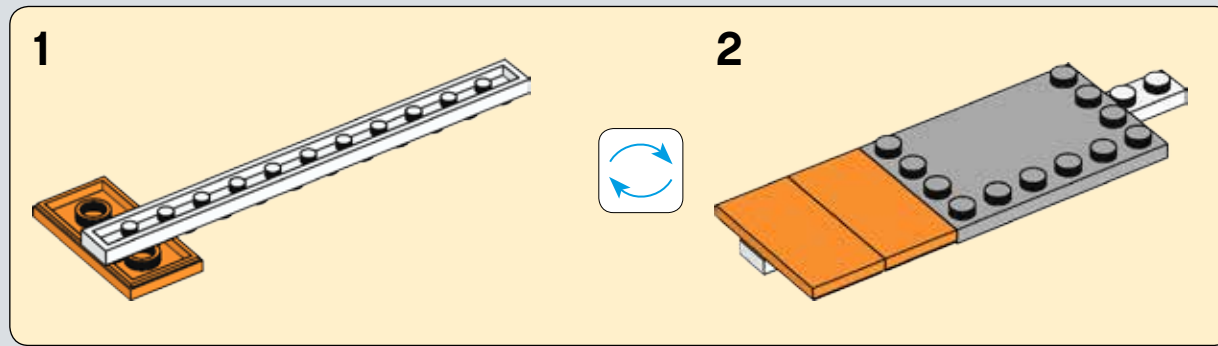

163

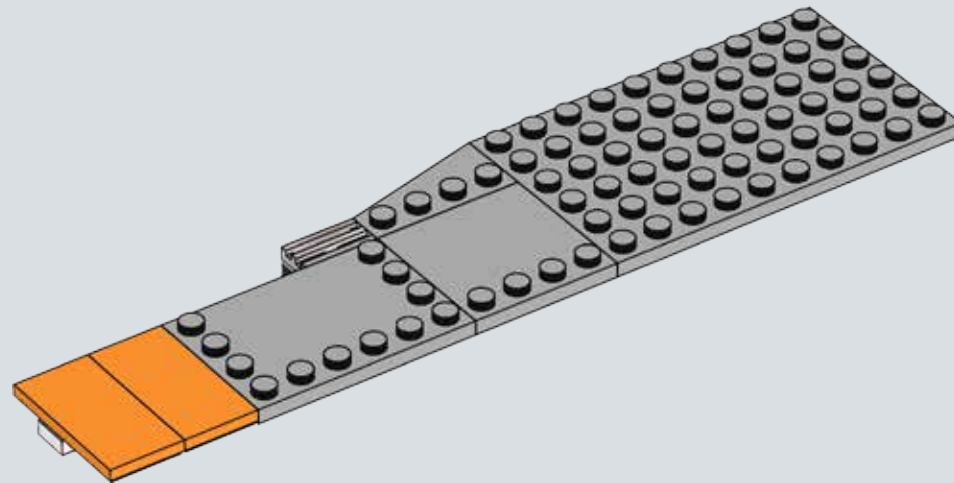

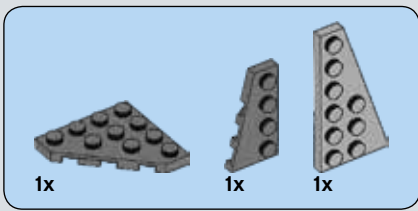

164

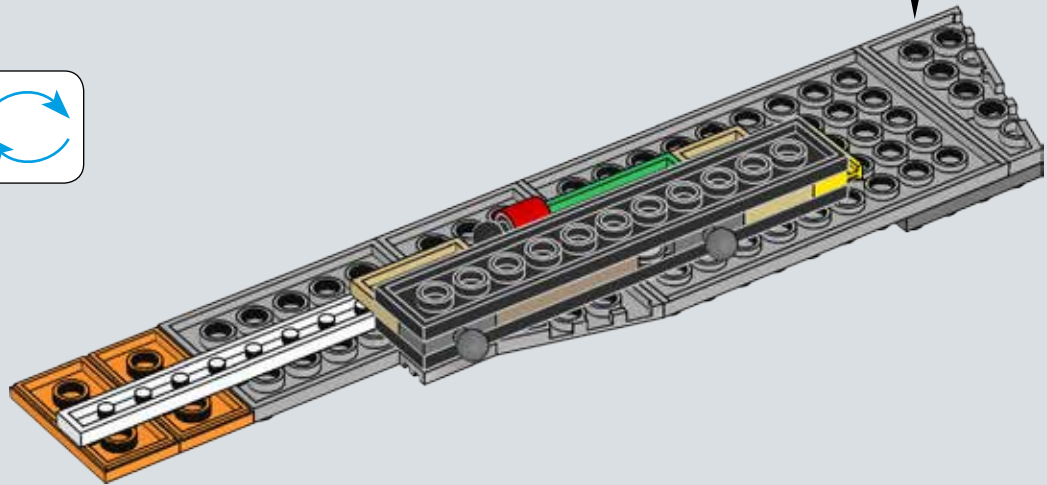
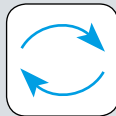
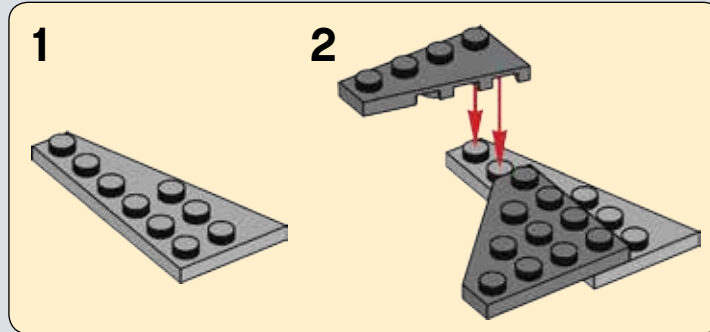

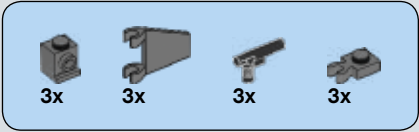

165

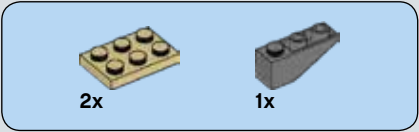
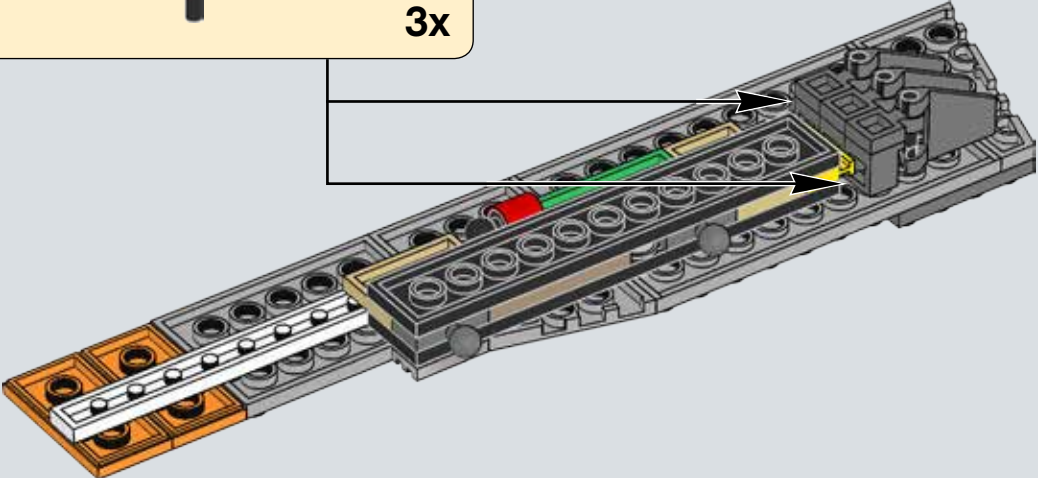
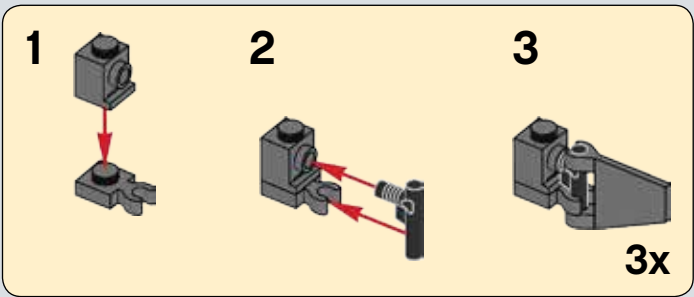

166

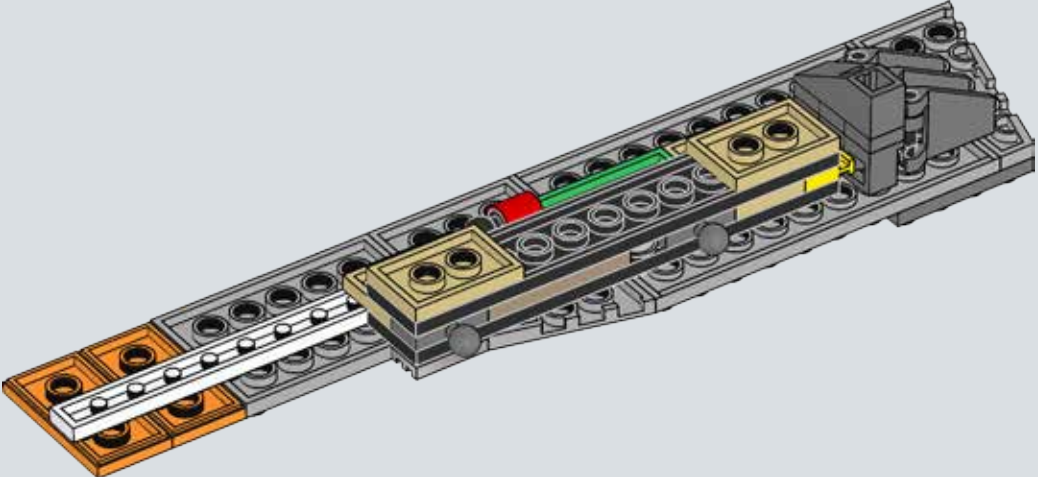

167

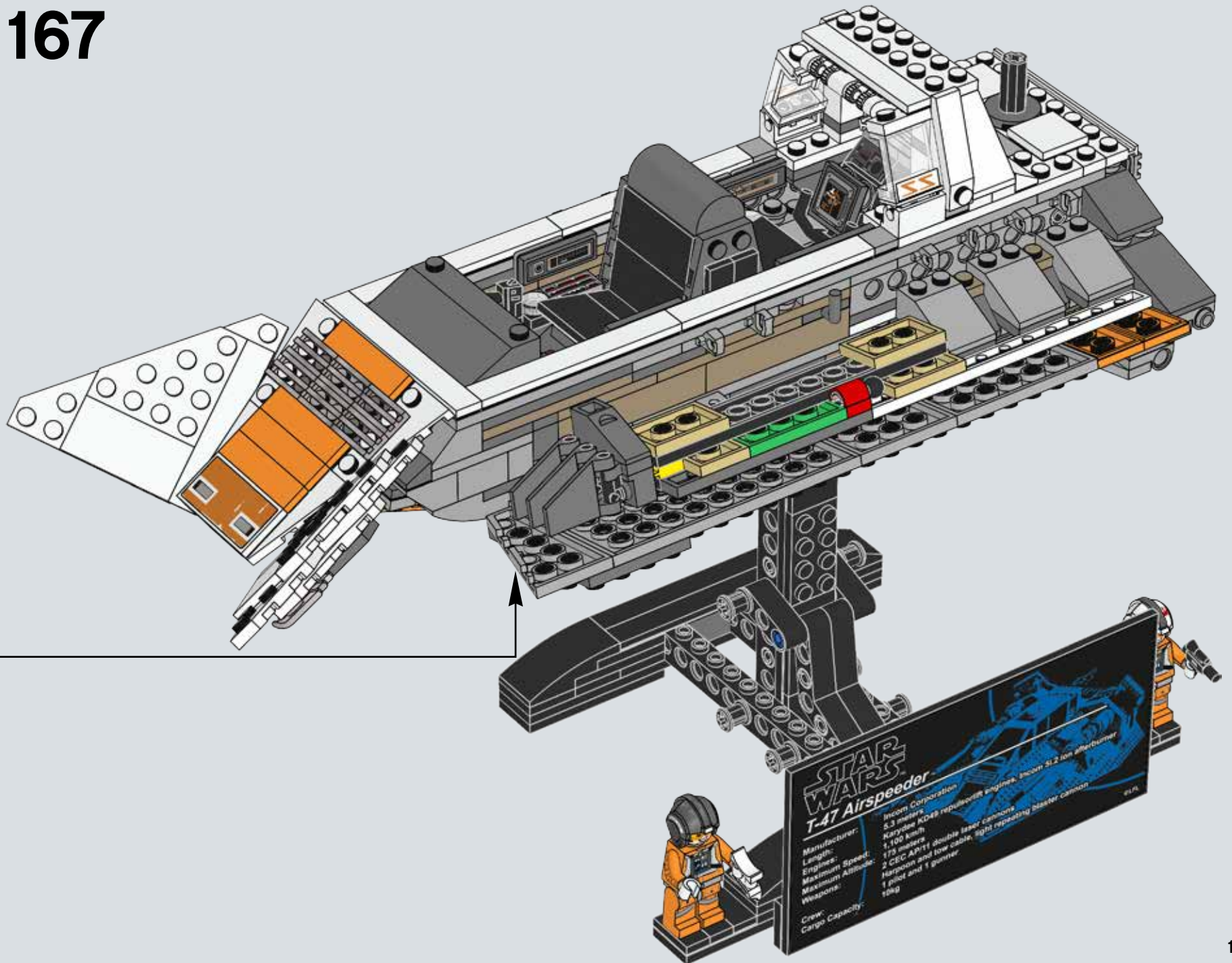

1x  1x 

168

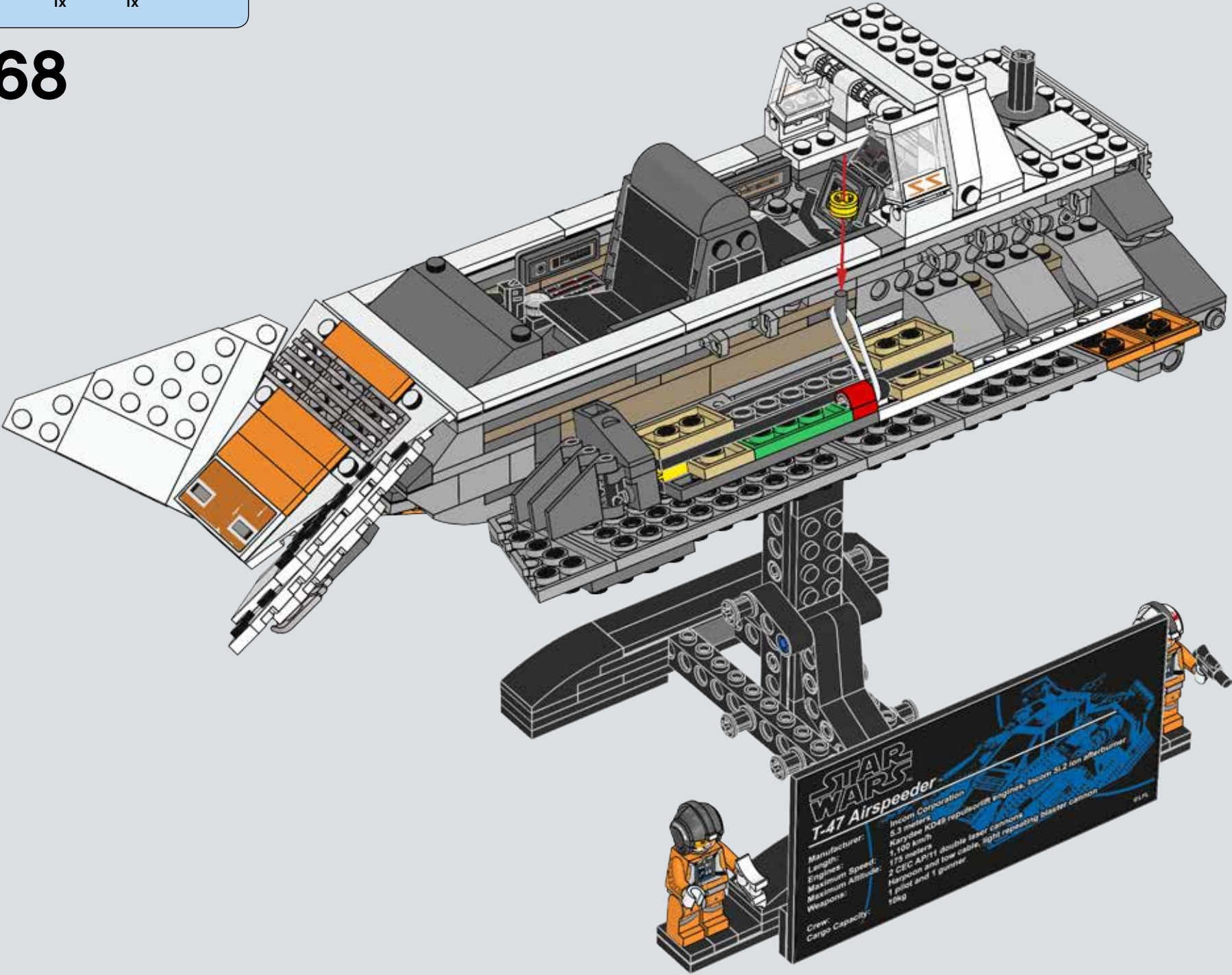

STAR WARS
T-47 Airspeeder

Manufacturer:	Incom Corporation
Length:	5.3 meters
Engine:	Karysae KD49 repulsorlift engines, Incom SL2 ion afterburner
Maximum Speed:	1,100 km/h
Maximum Altitude:	170 meters
Weapons:	2 GEC AP/11 double laser cannons Harpoon and tow cable, light repeating blaster cannon
Crew:	1 pilot and 1 gunner
Cargo Capacity:	10kg

© LFL

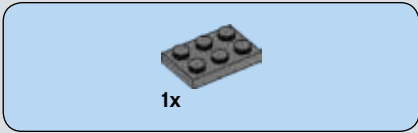

169

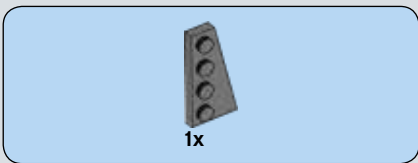
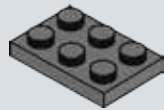

170

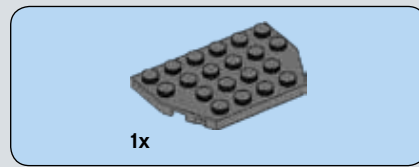
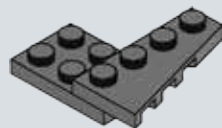

171

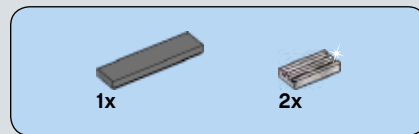
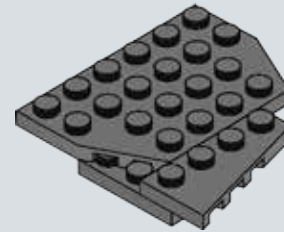

172

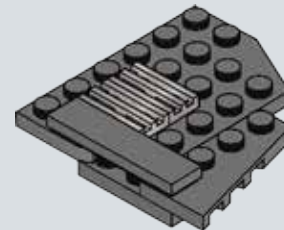

3x

173



1x 1x 1x

174

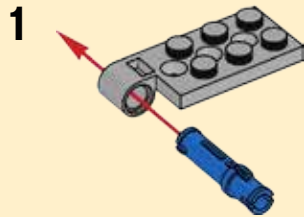
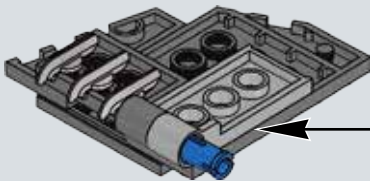

1x

1x

175

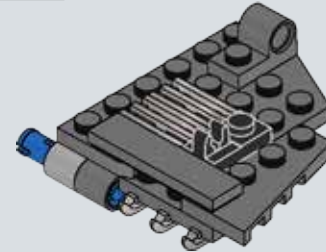
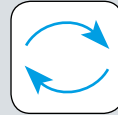

1x

1x

1x

176

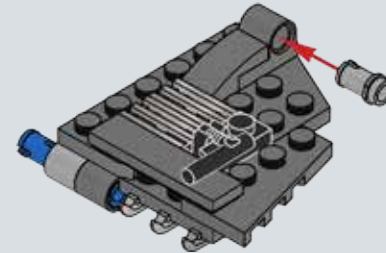

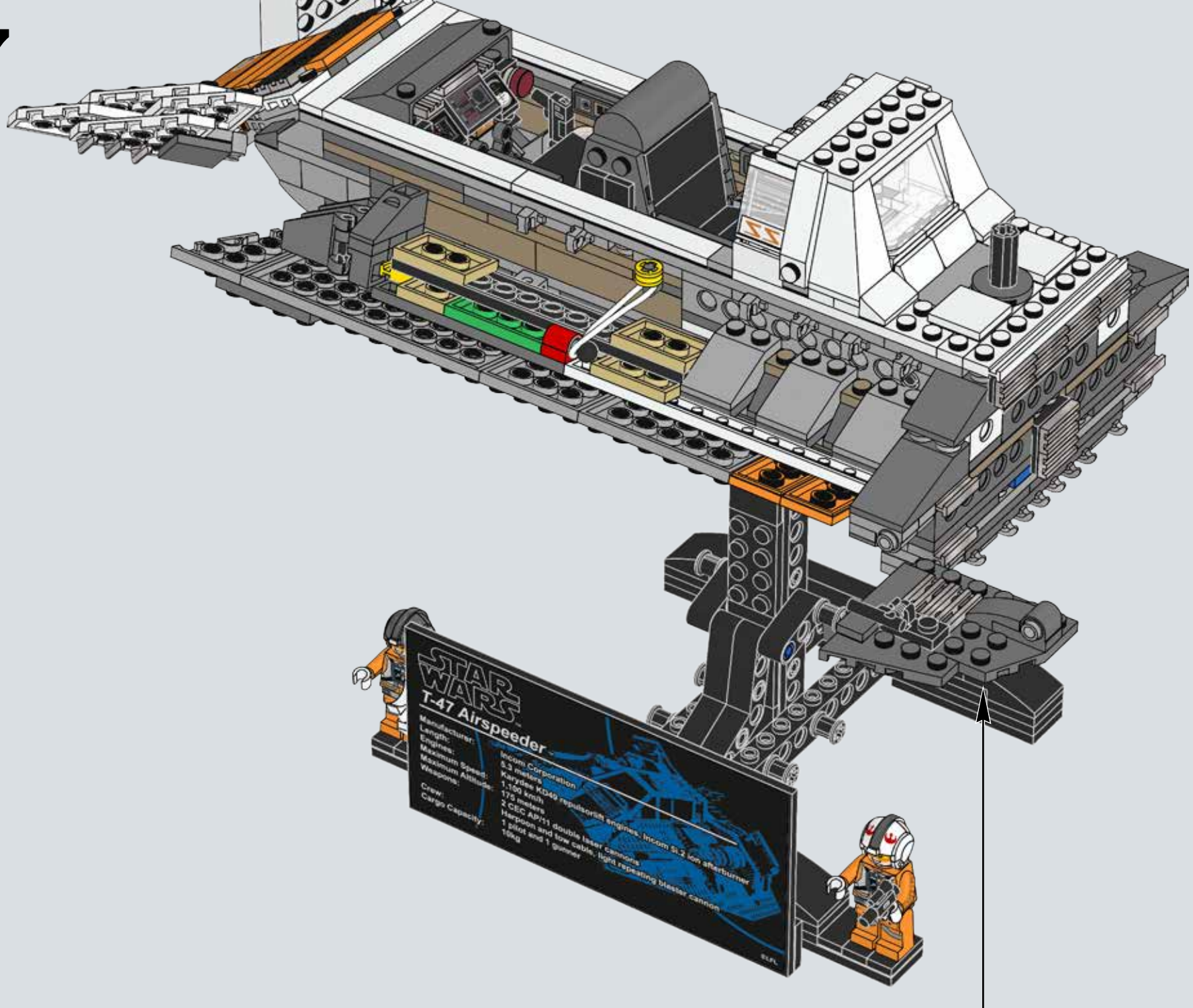

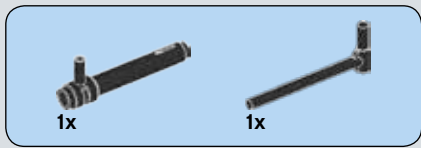

178

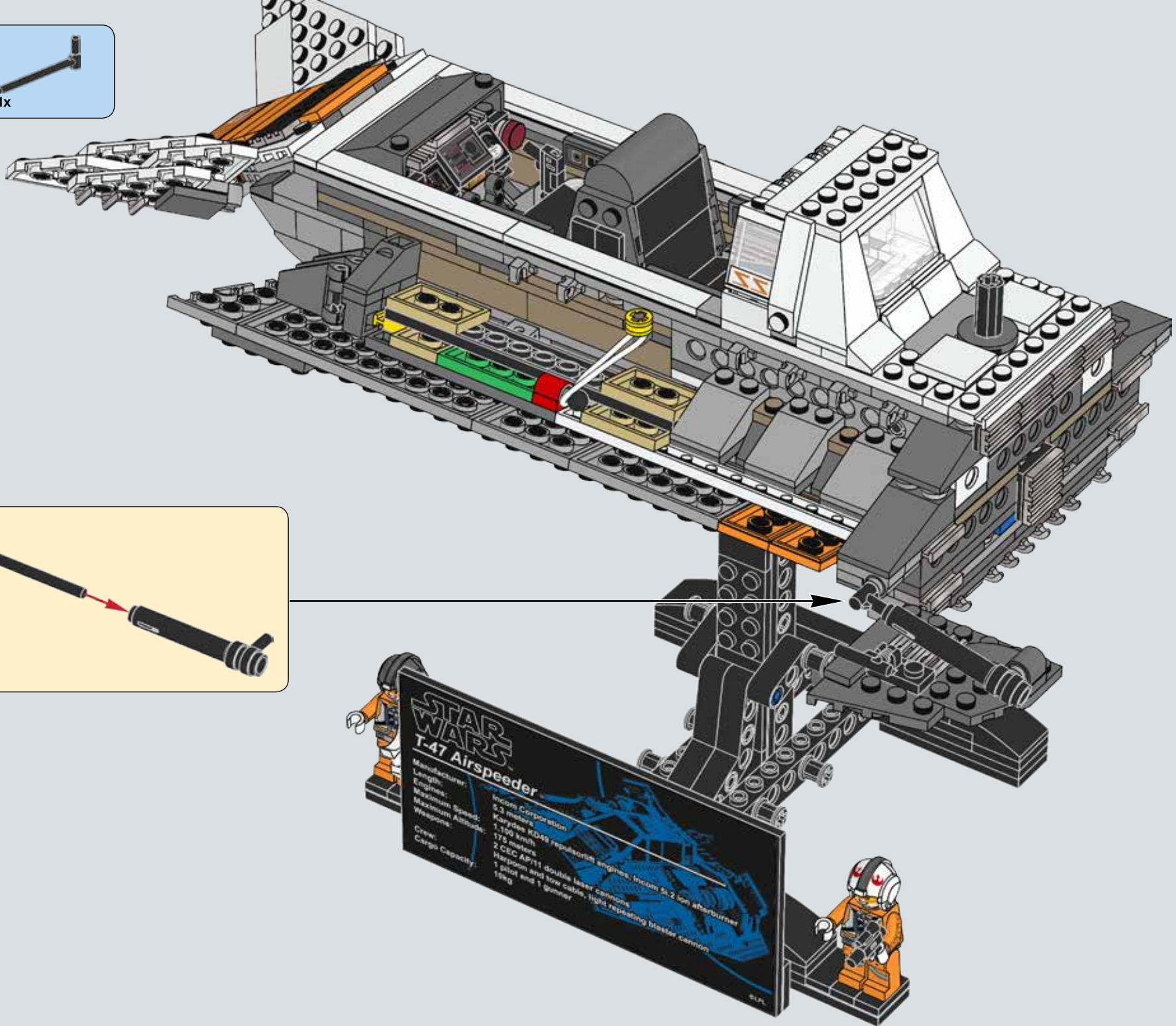

STAR WARS
T-47 Airspeeder

Manufacturer:	Incom Corporation
Length:	5.3 meters
Maximum Speed:	Karydek KD40 repulsorlift engines, Incom S1-2 ion afterburner
Maximum Altitude:	1,100 kmh
Wesons:	174 meters
Crew:	2 CEC AP11 double laser cannons
Cargo Capacity:	Harpoon and tow cable, light repeating blaster cannon
	1 pilot and 1 gunner
	16kg

S.P.A.

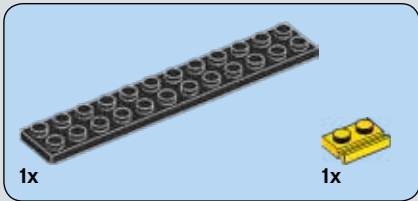
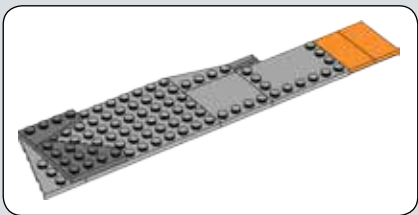

179

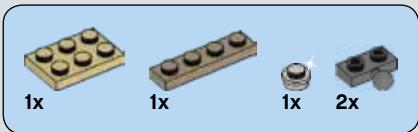
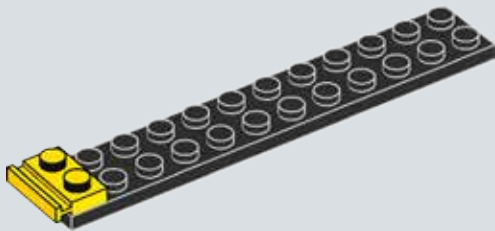

180

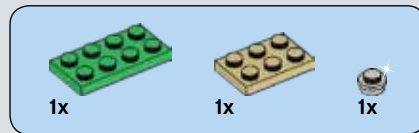
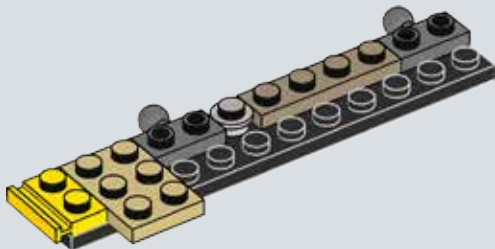

181

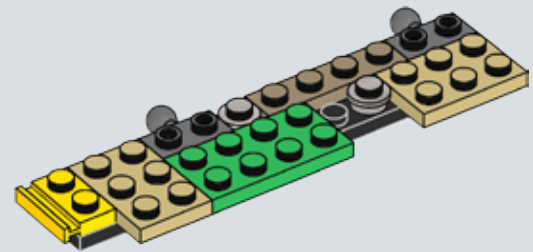

182

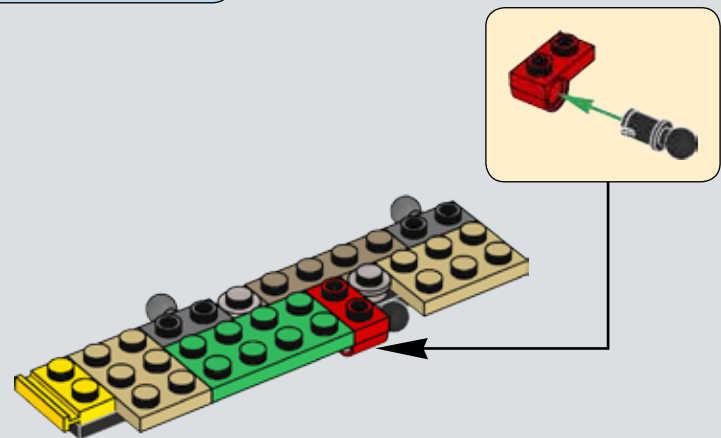

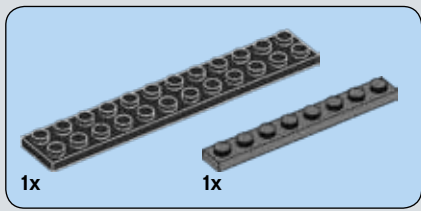

183

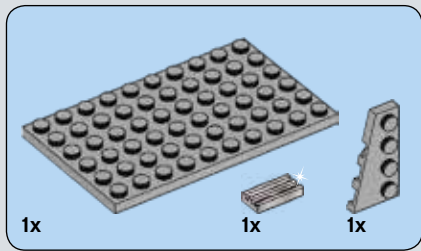
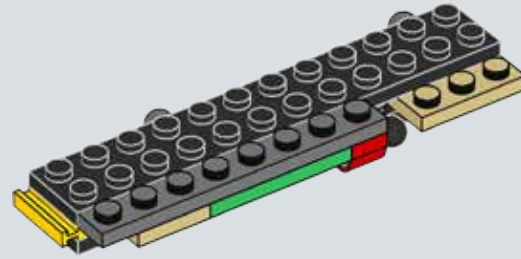

184

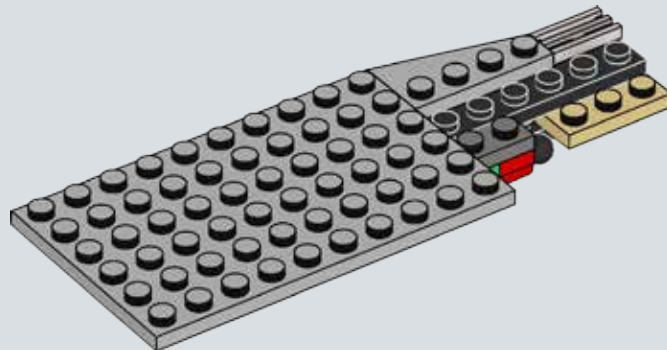

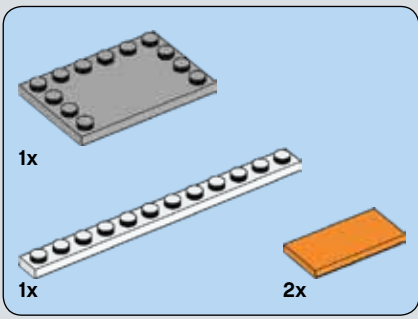

185

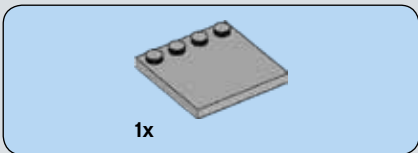
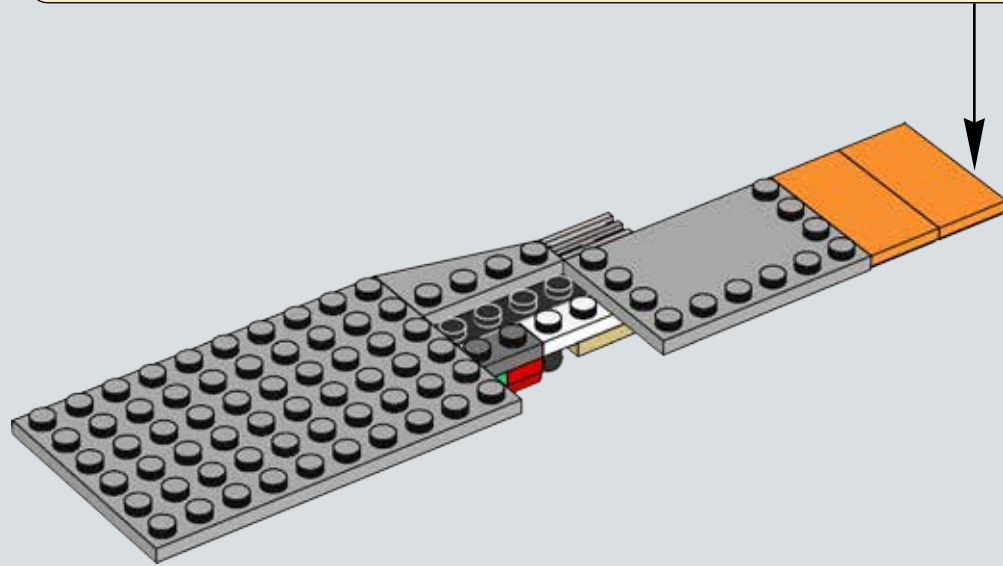
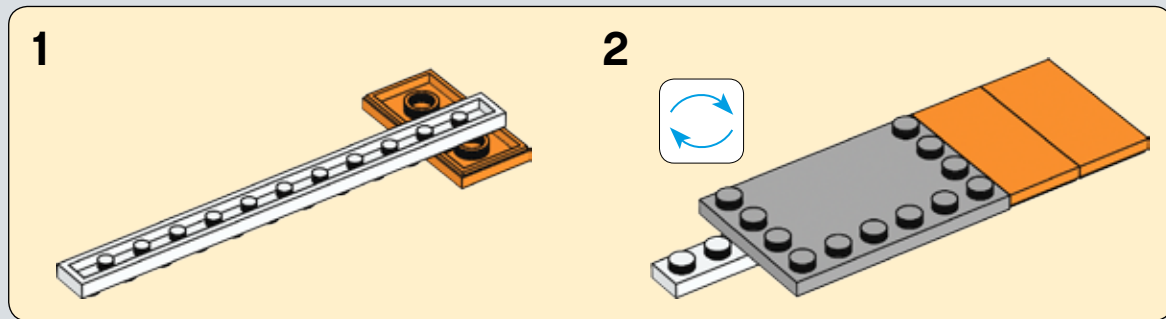

186

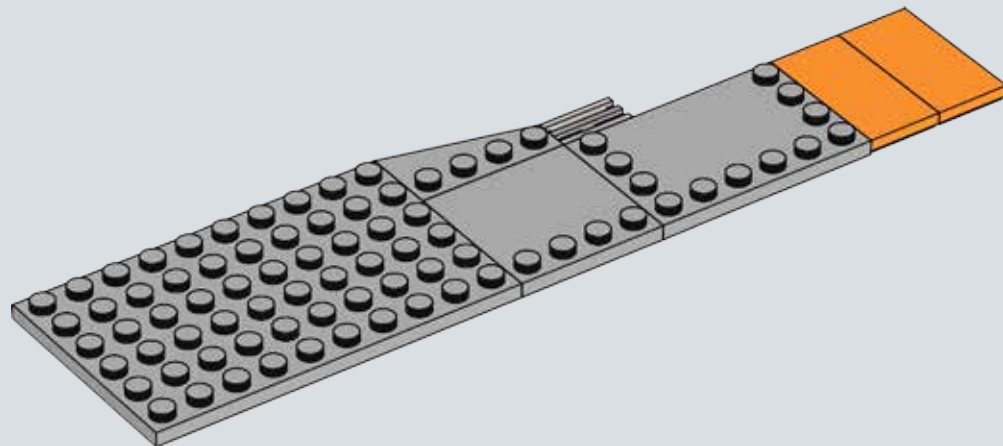

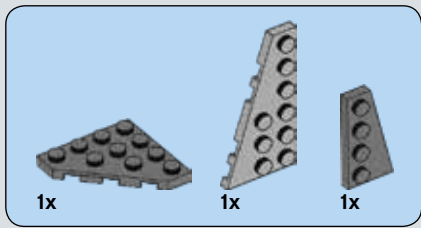

187

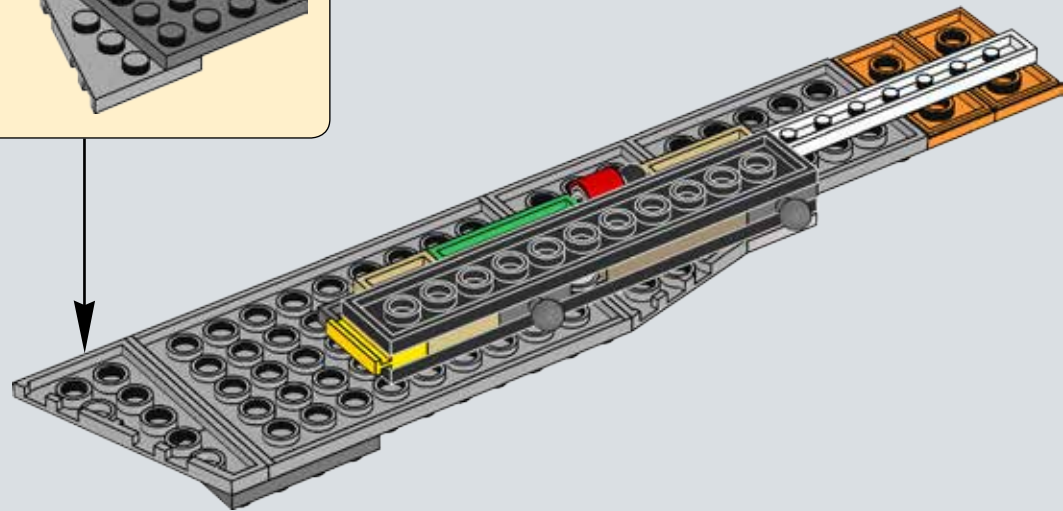
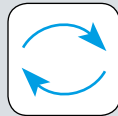
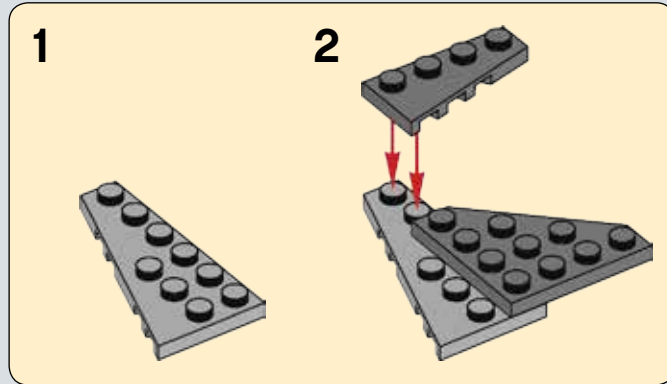

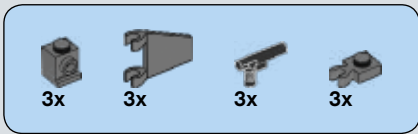

188

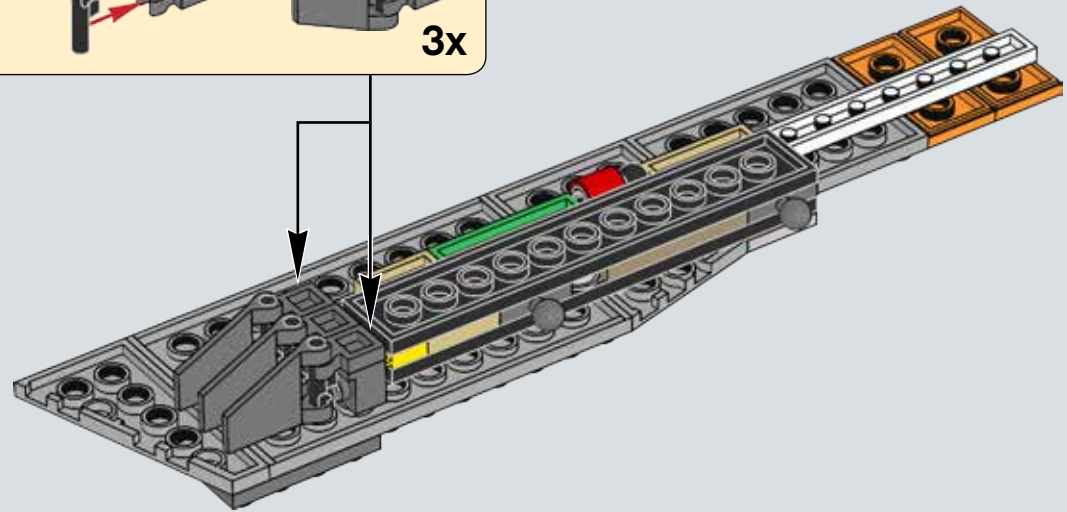
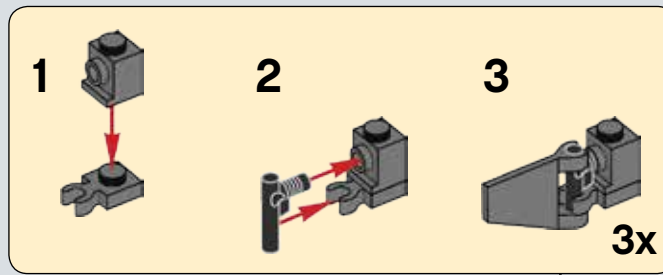

189

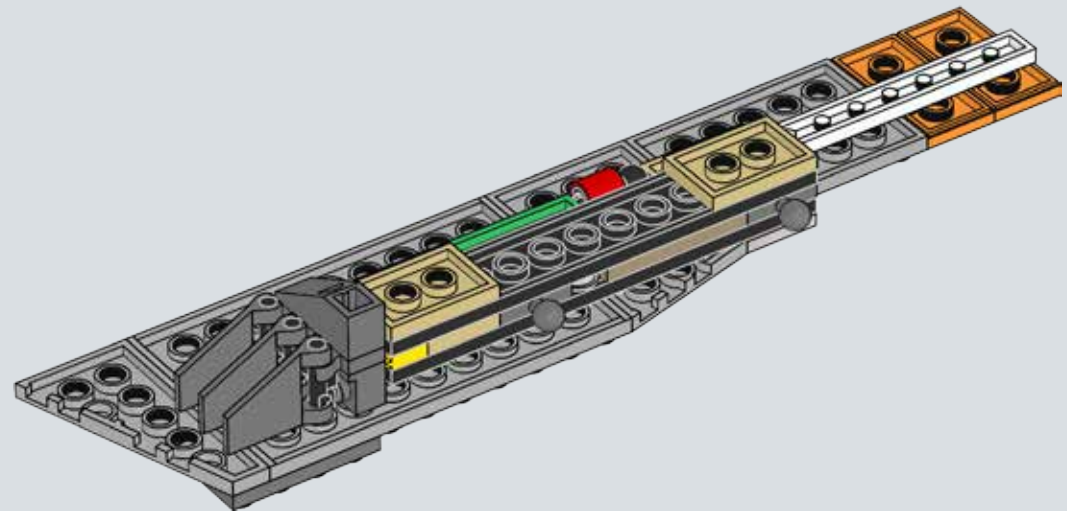

190

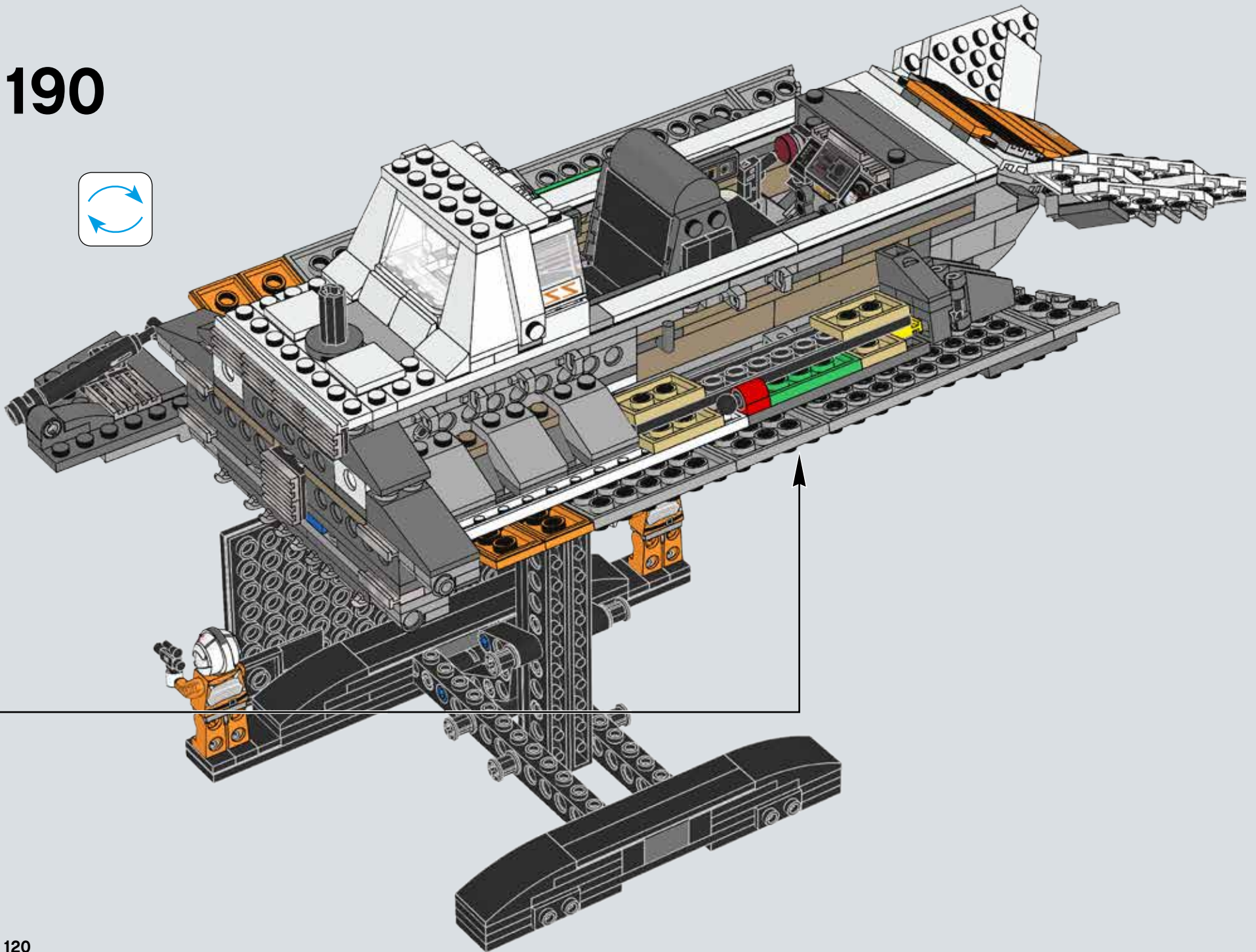

1x  1x 

191

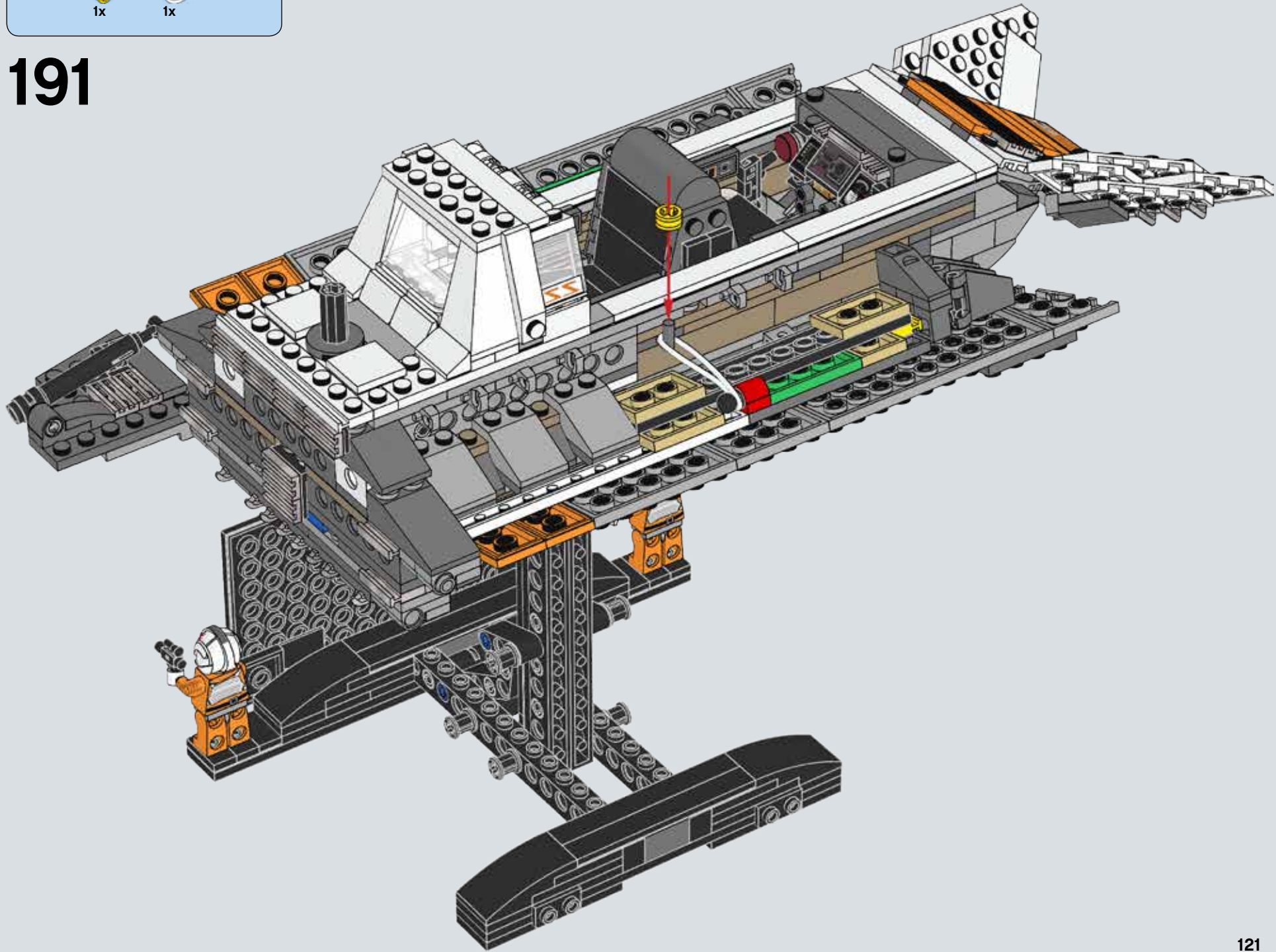

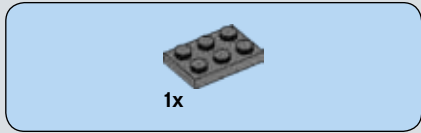

192



193

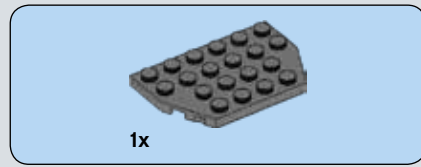
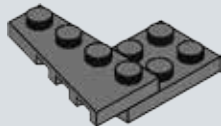

194

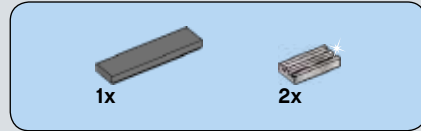
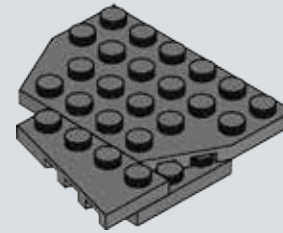

195

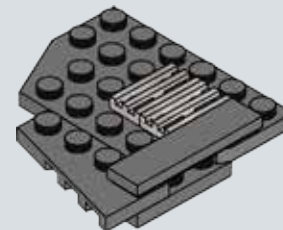

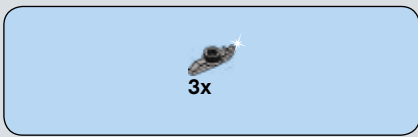

196

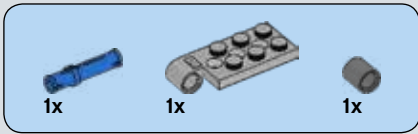
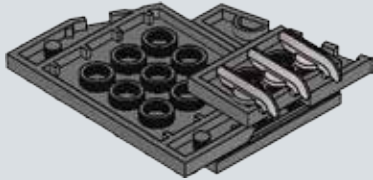
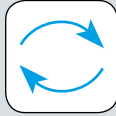

197

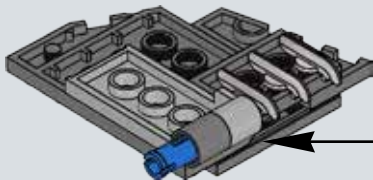
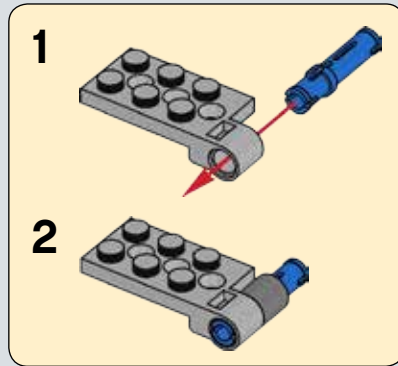

198

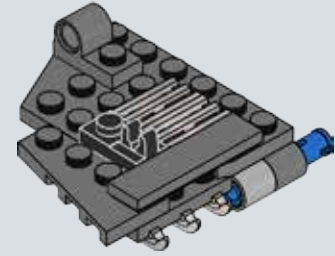
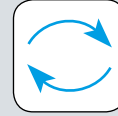

199

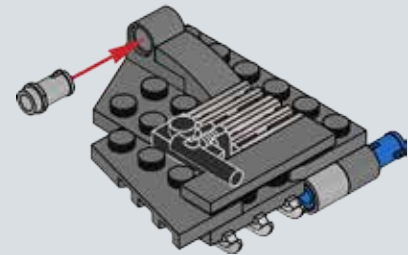

200

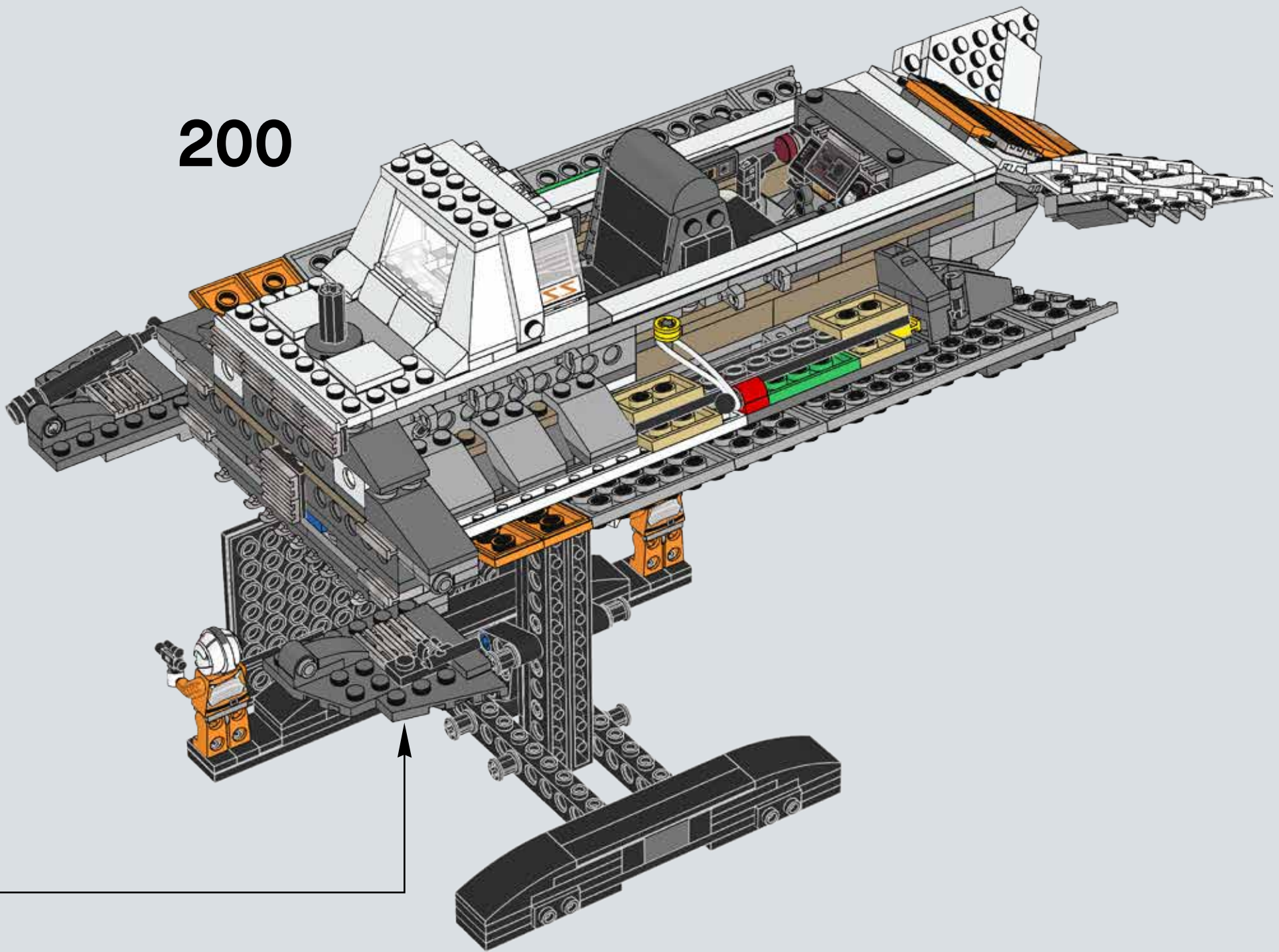

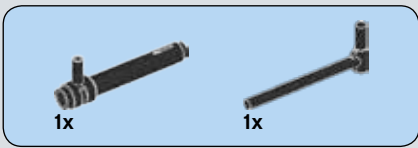

201

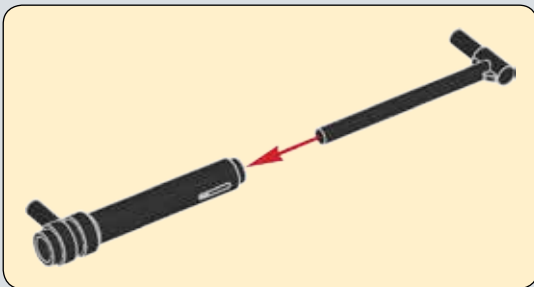
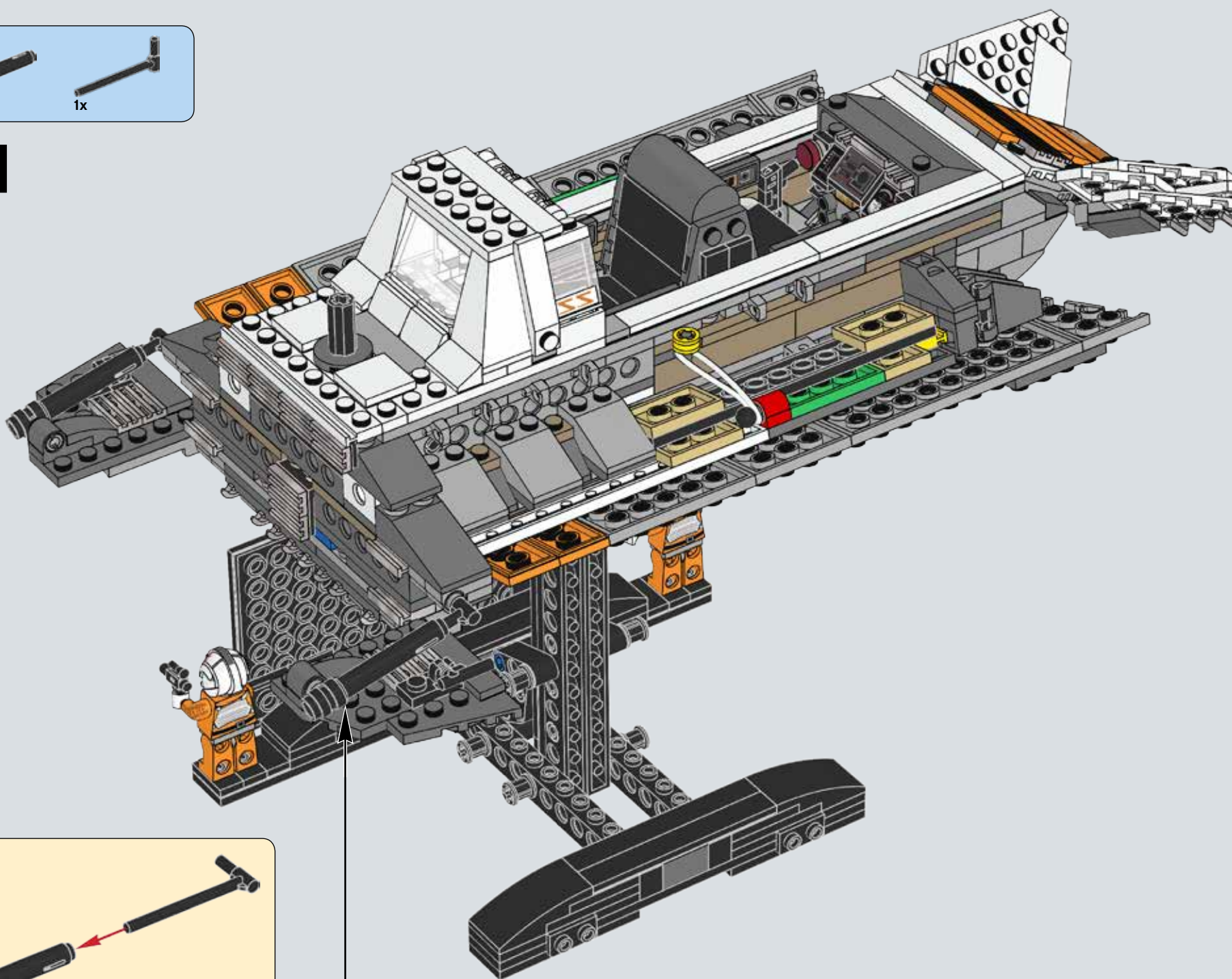

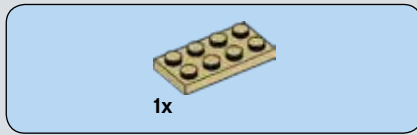
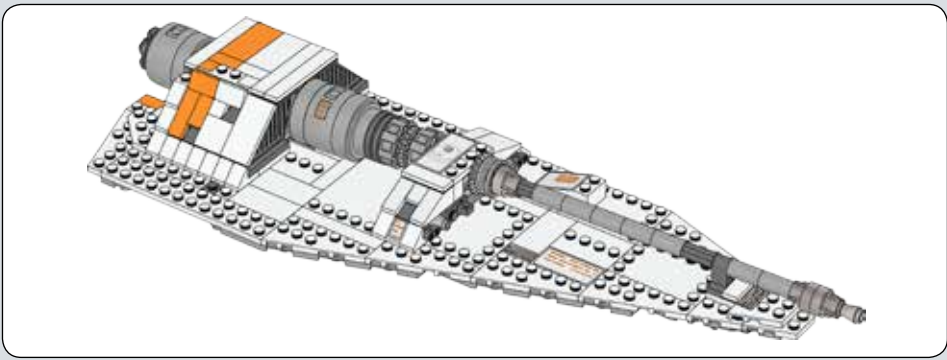

203

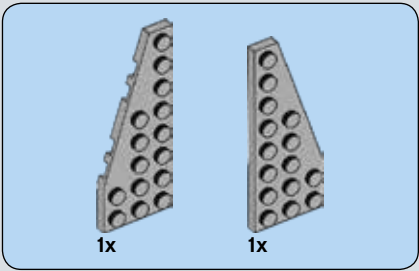
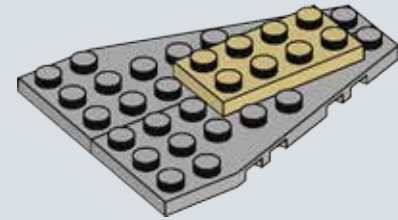
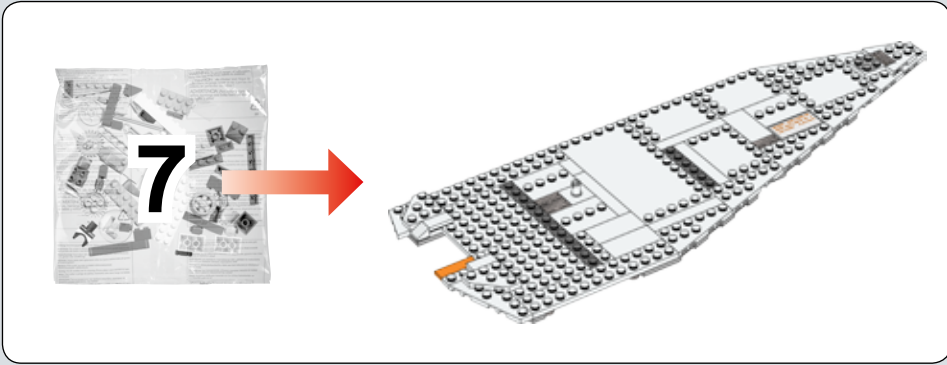

202

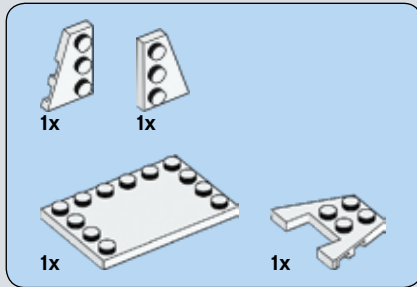
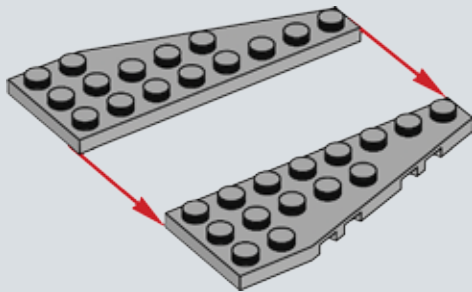

204

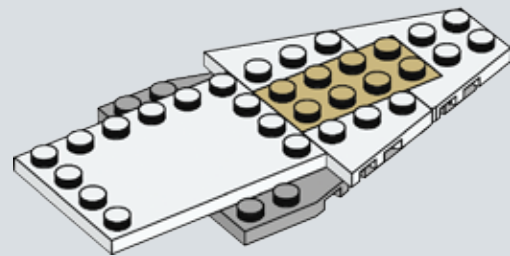

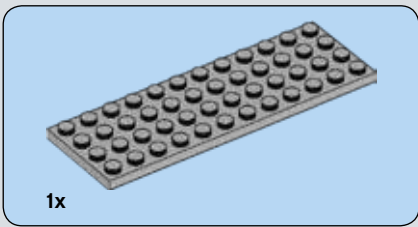

205

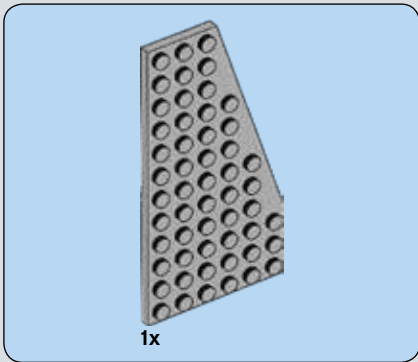
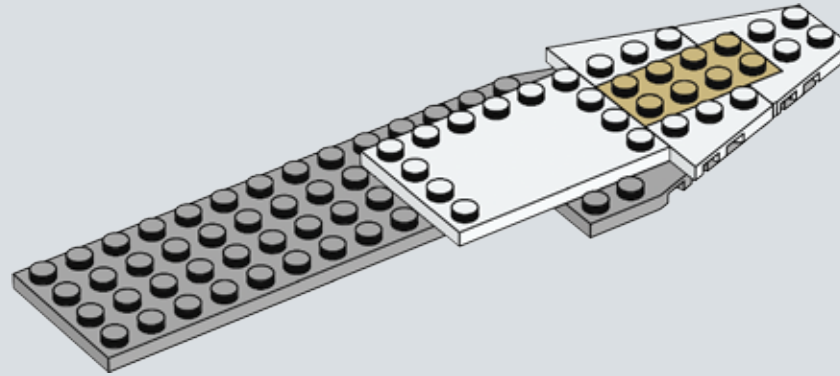

206

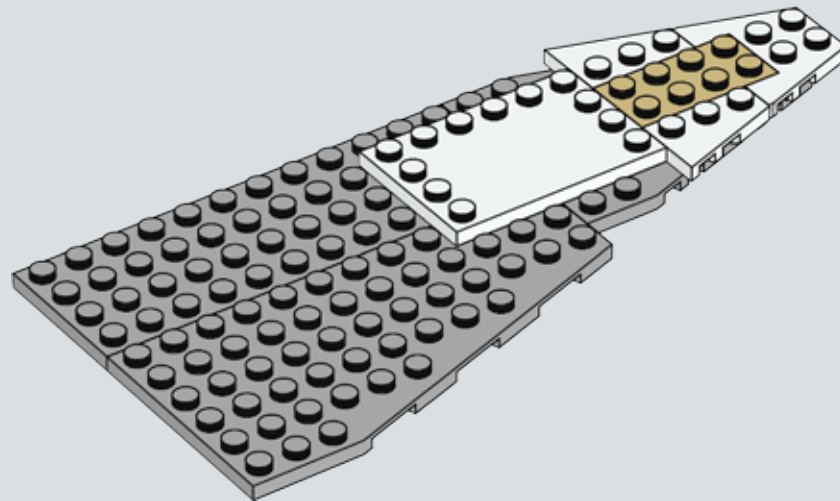

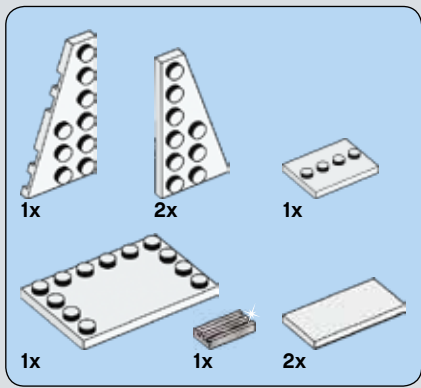

207

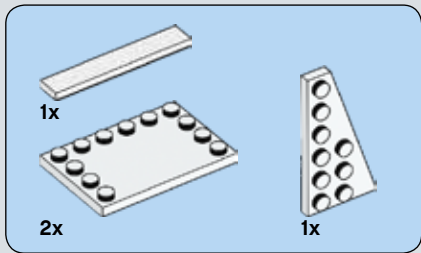
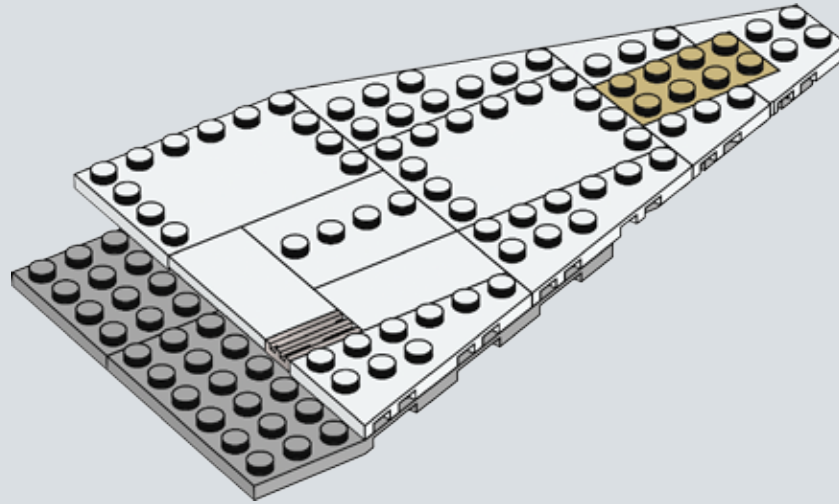

208

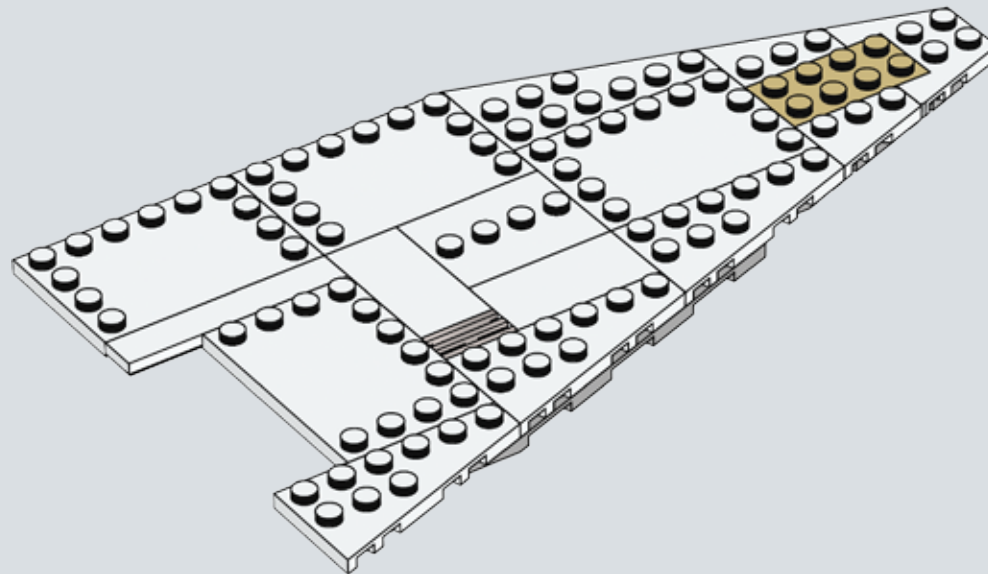

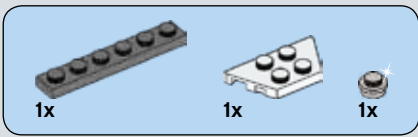

209

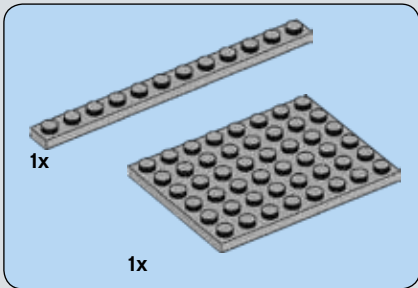
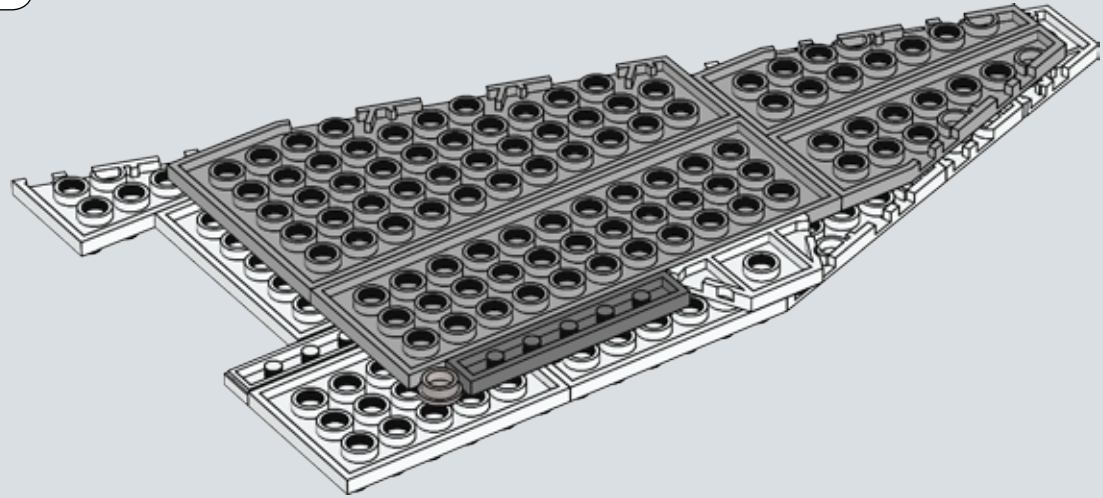
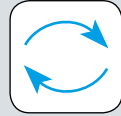

210

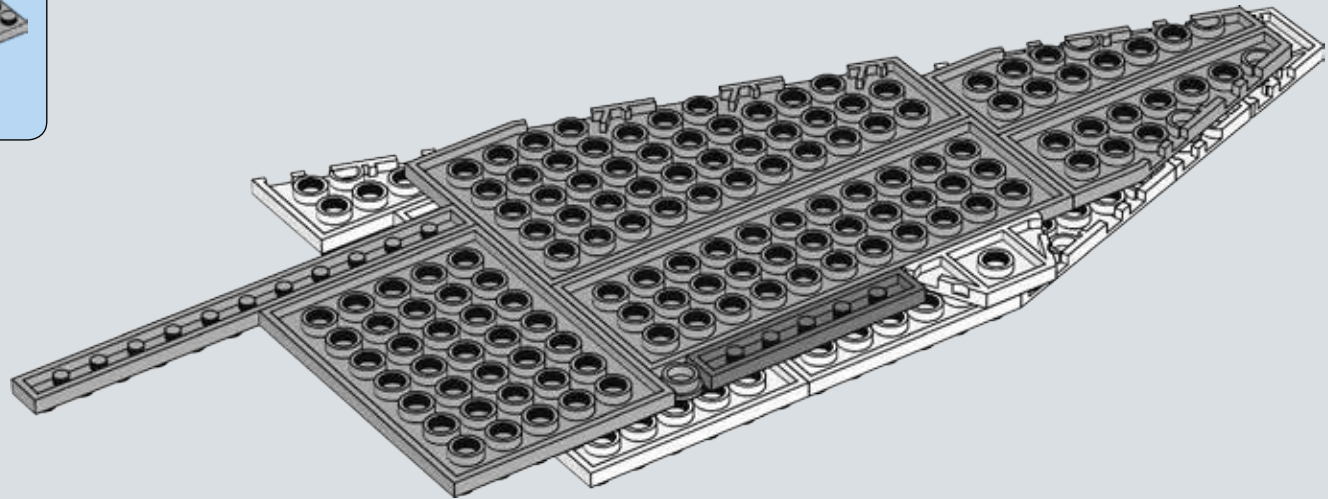

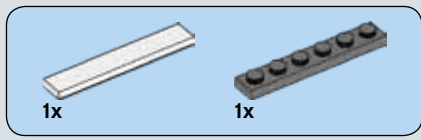

211

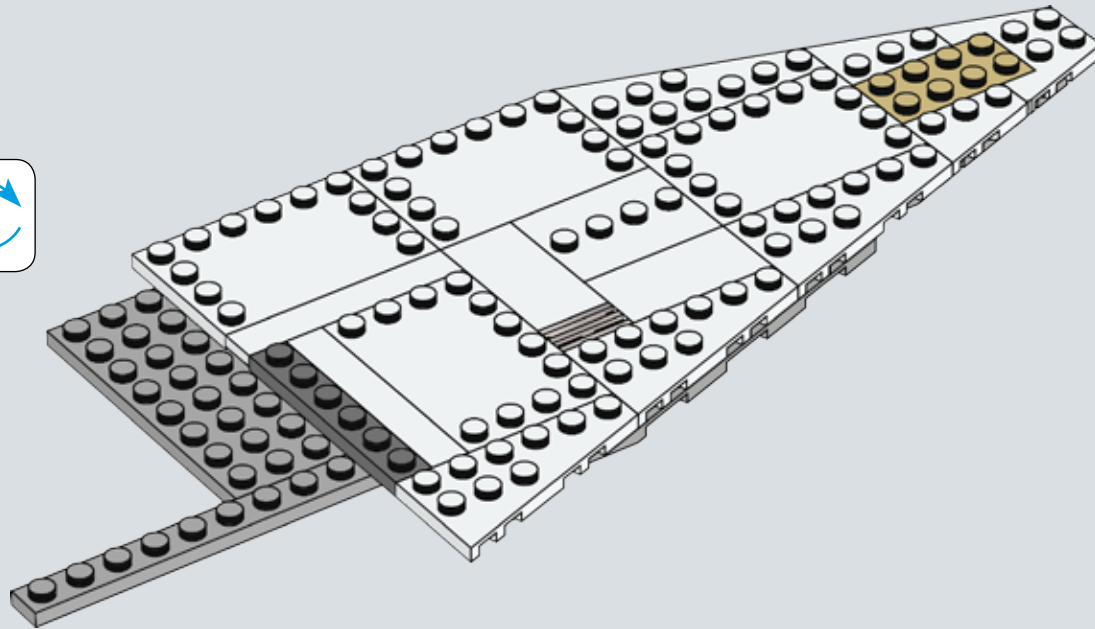
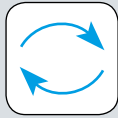

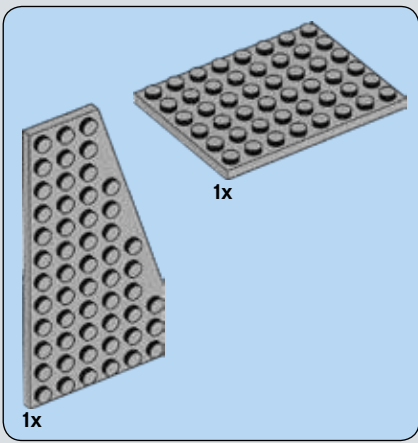

212

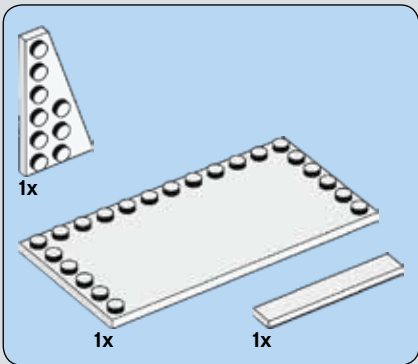
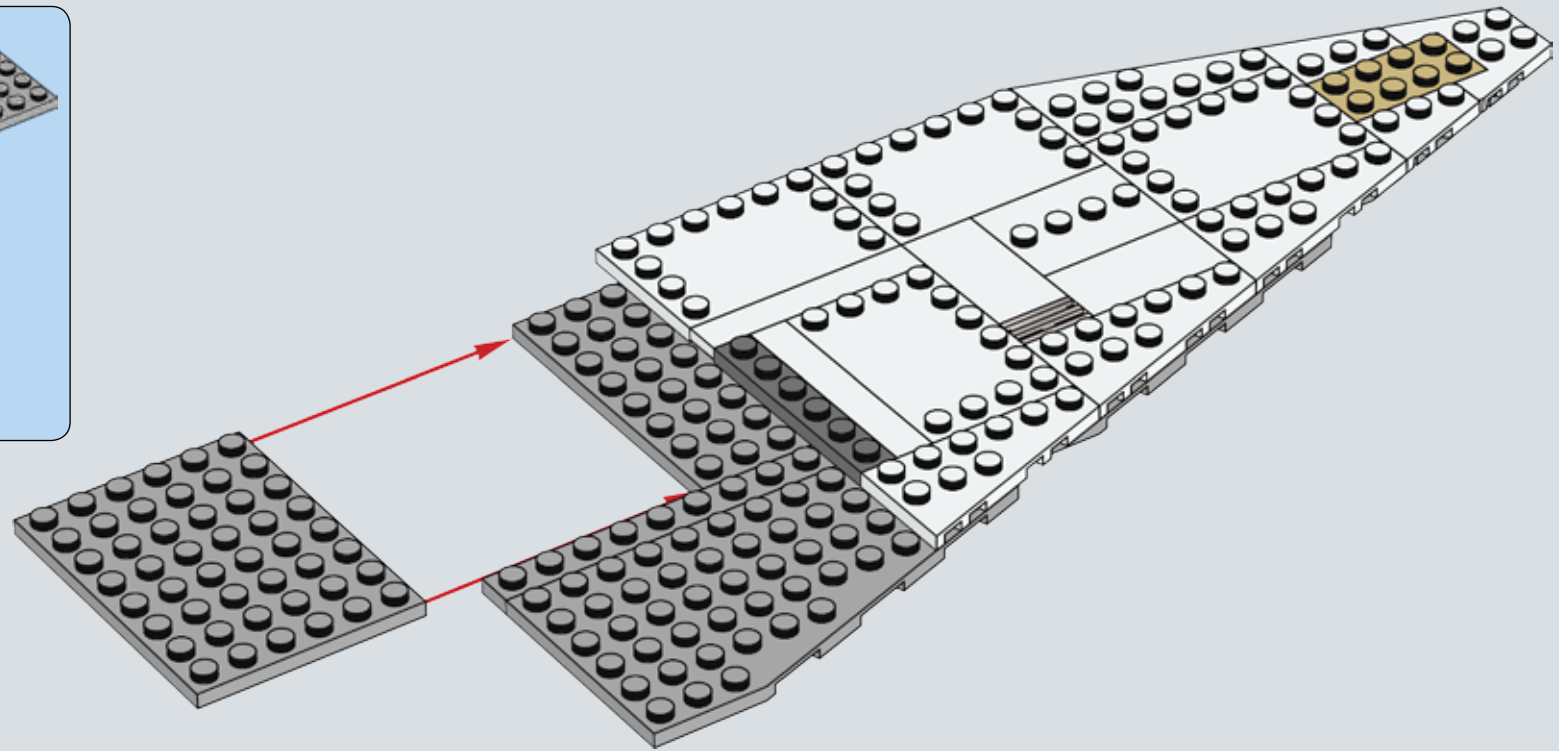

213

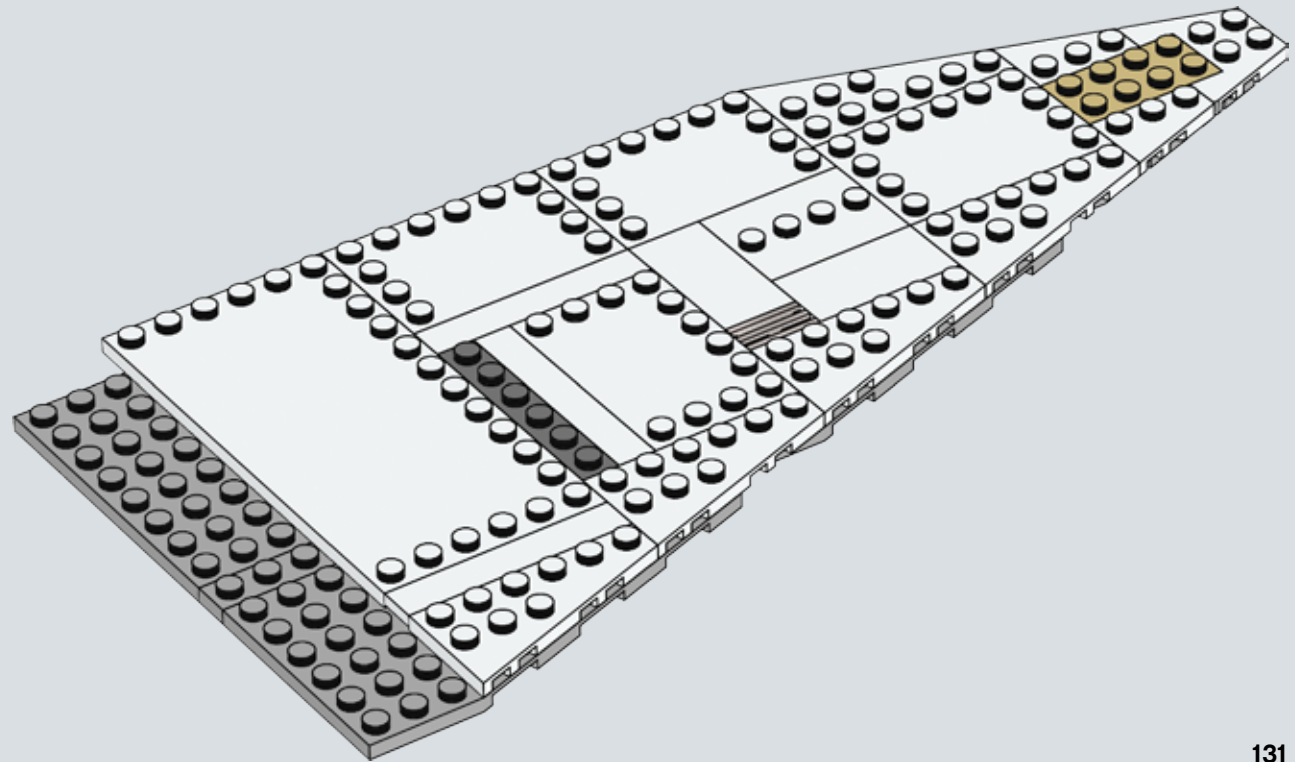

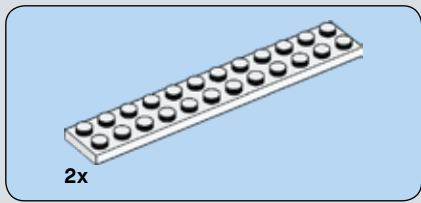

214

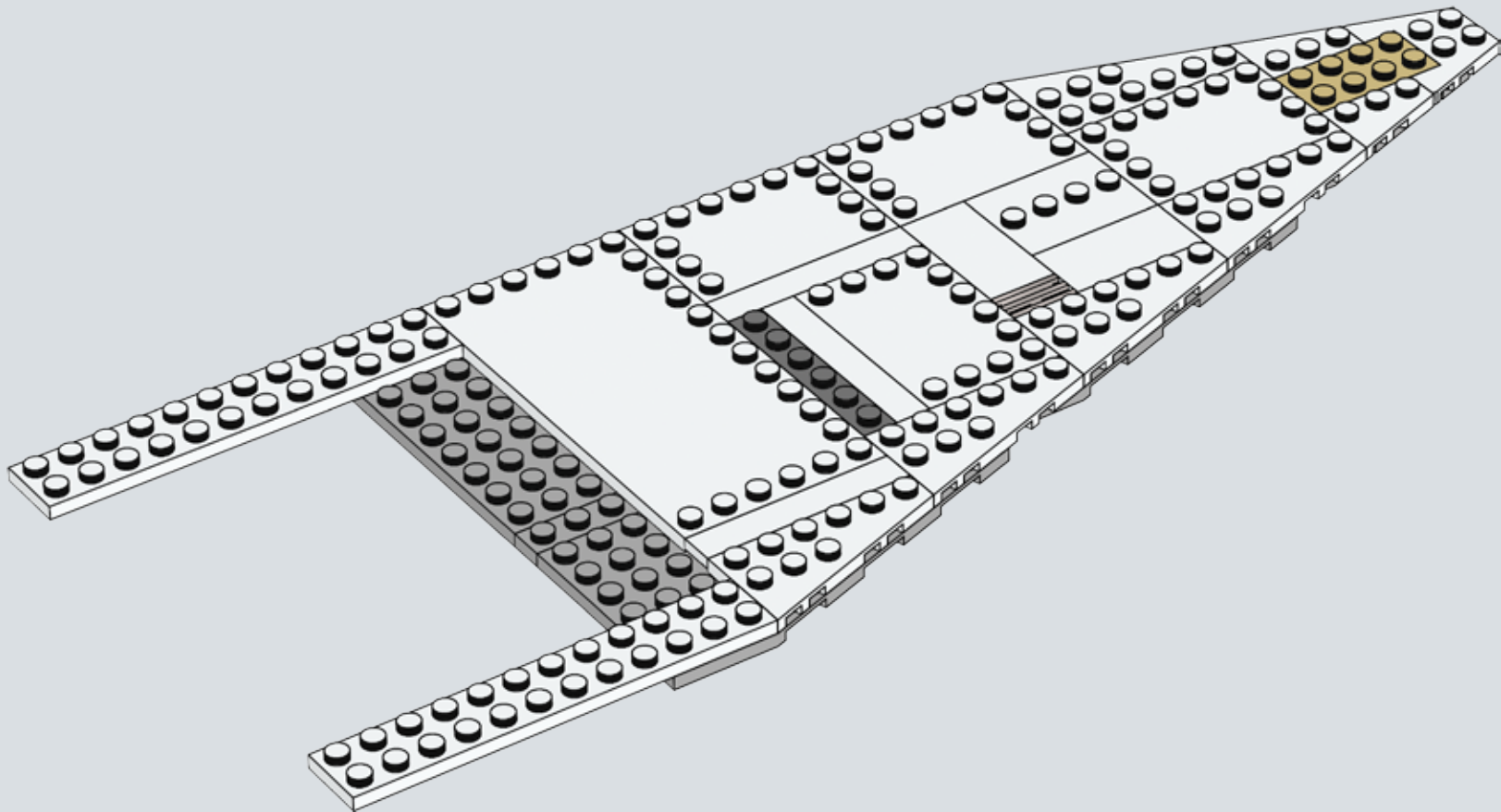

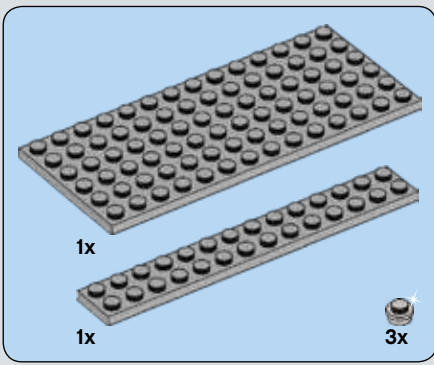

215

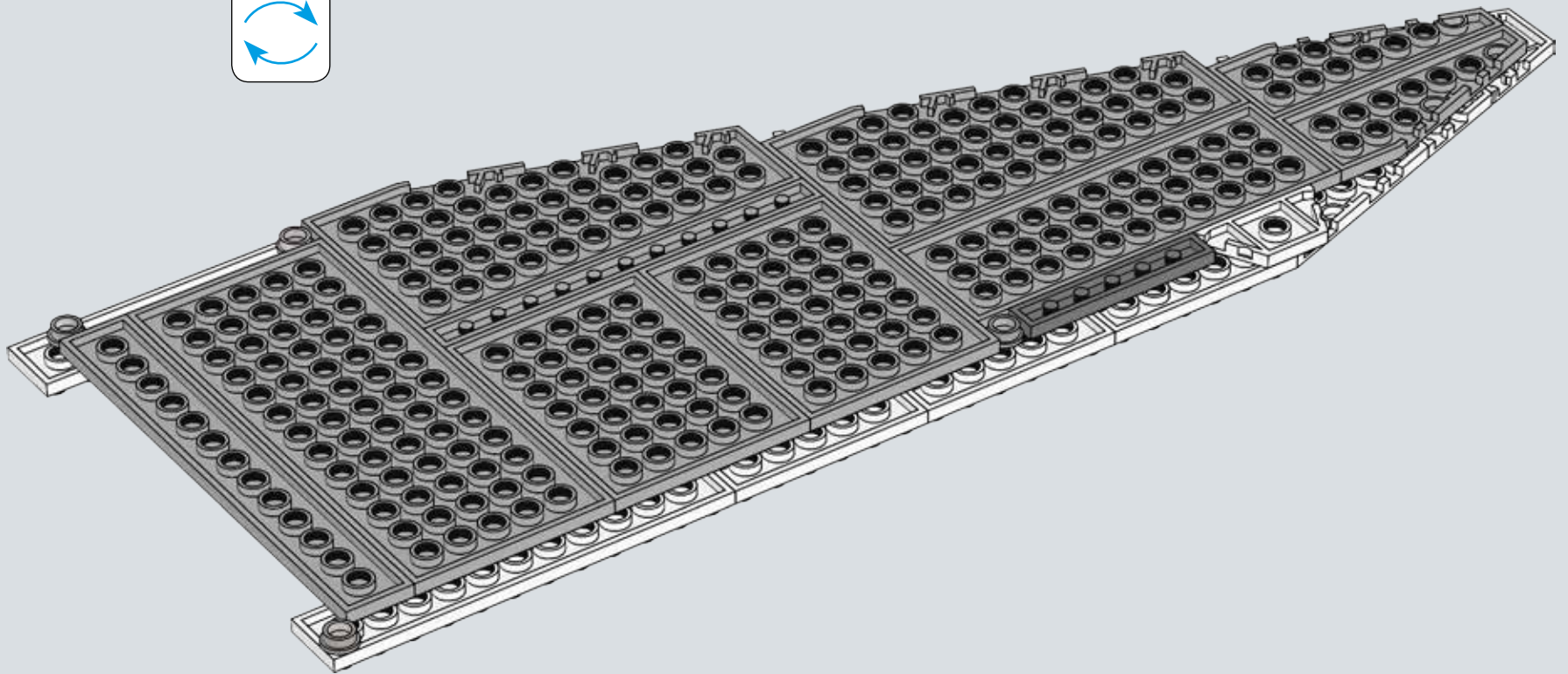
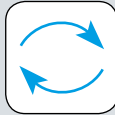

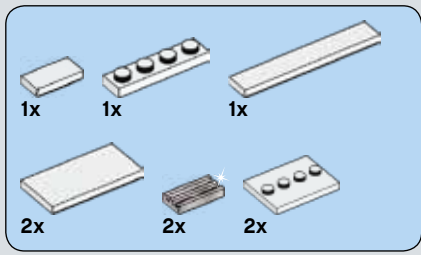

216

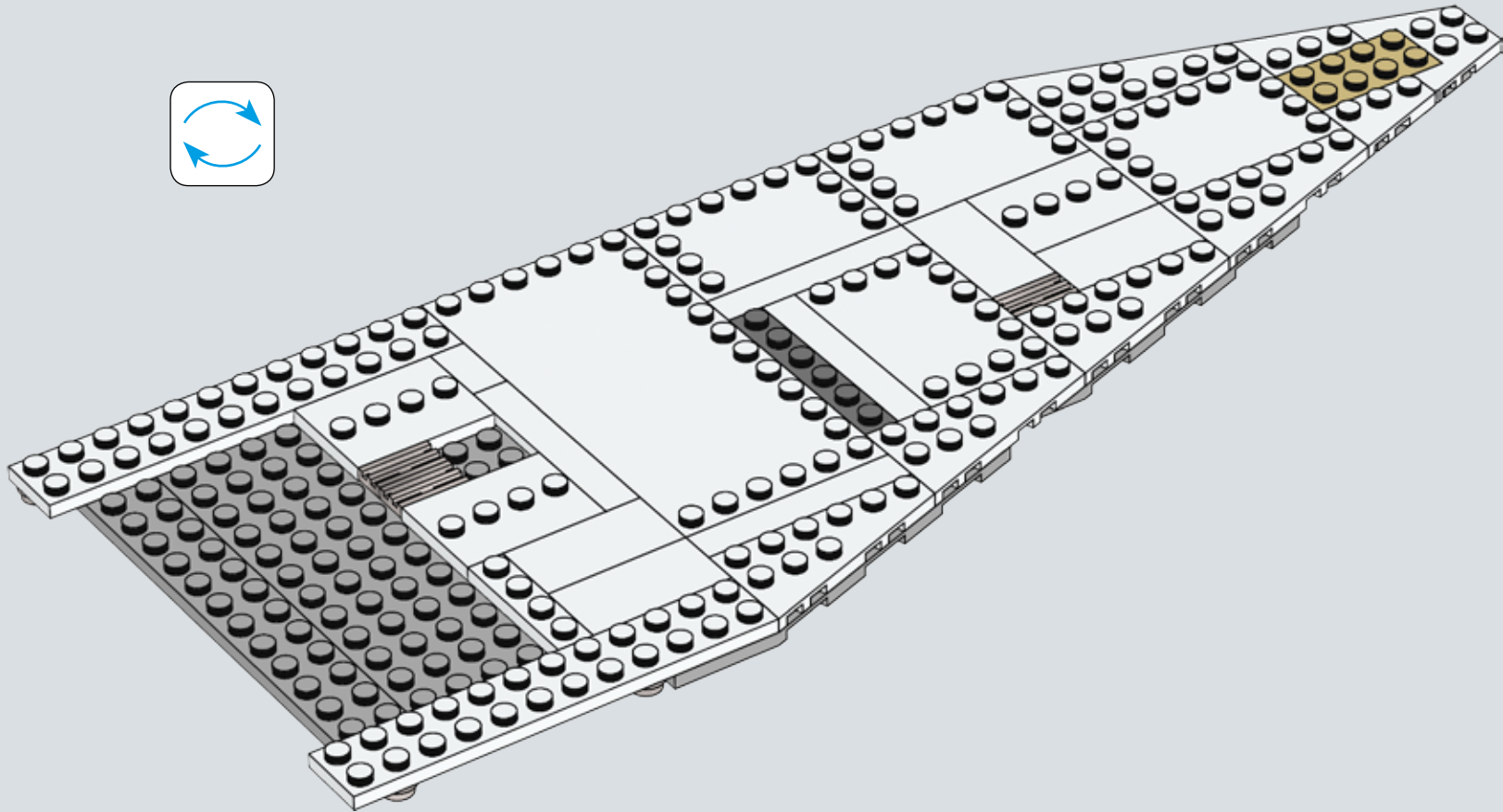

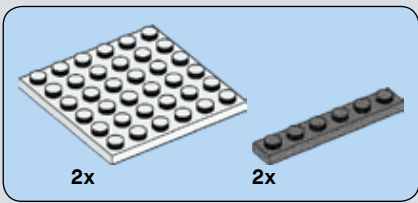

217

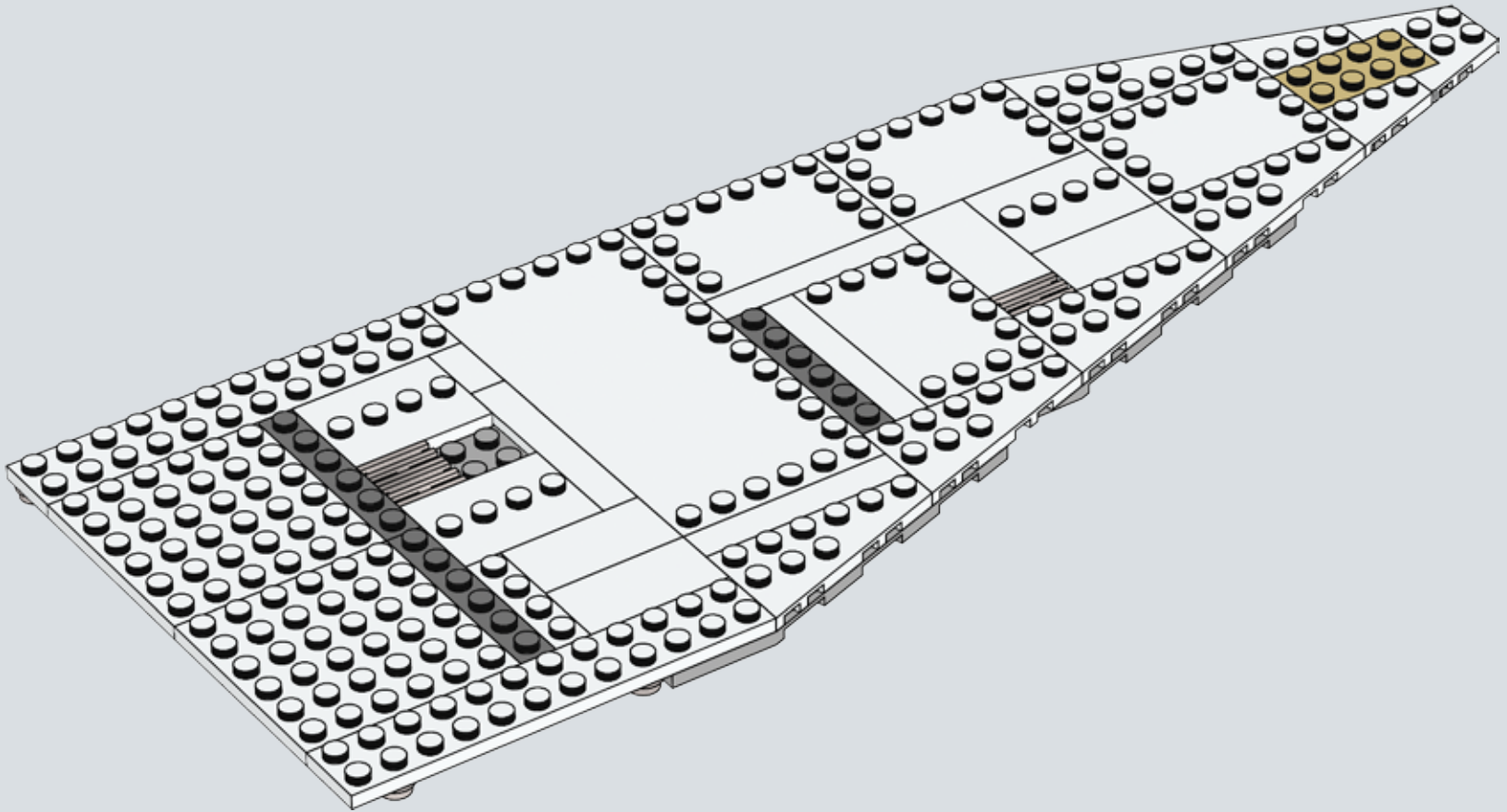

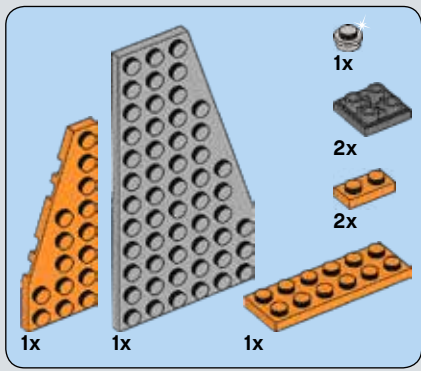

218

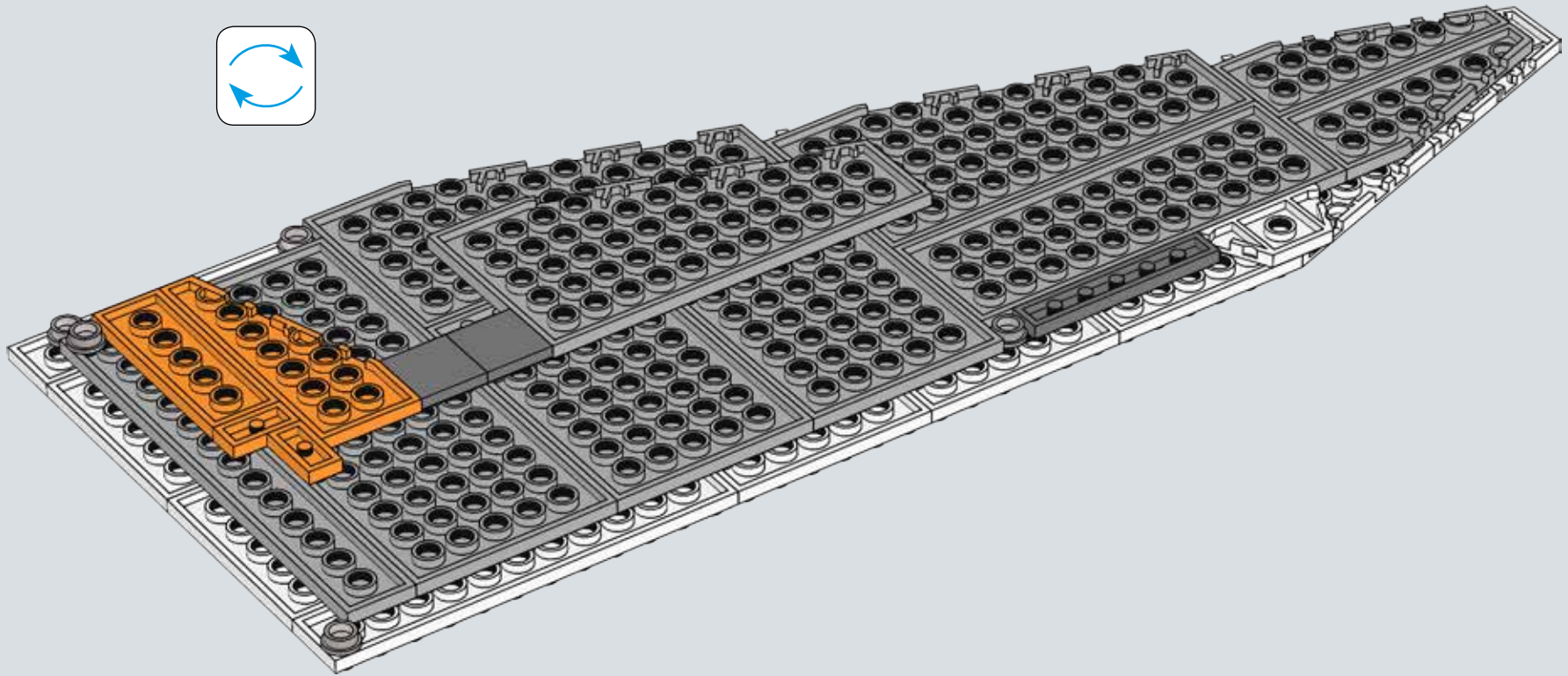
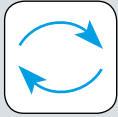

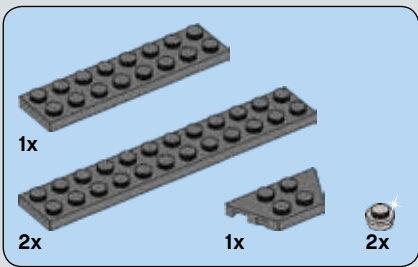

219

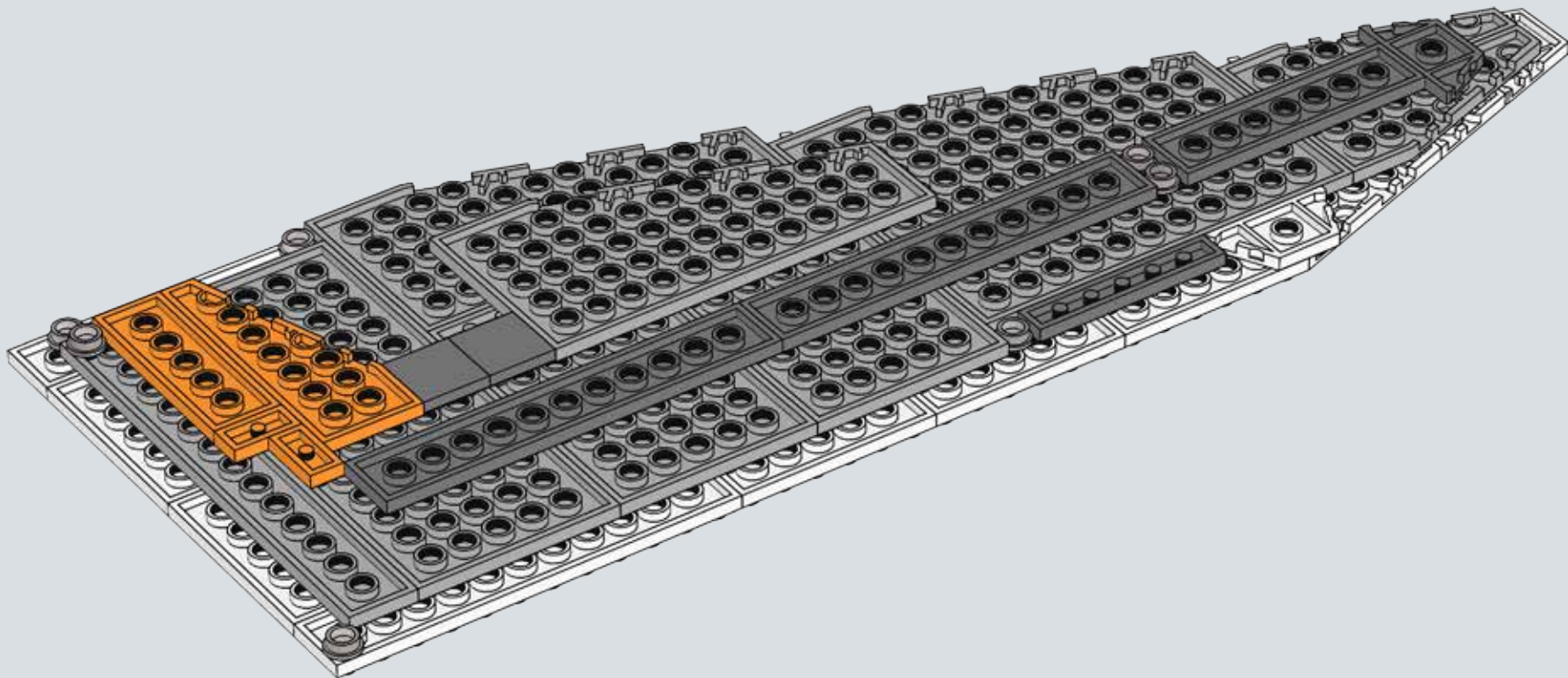

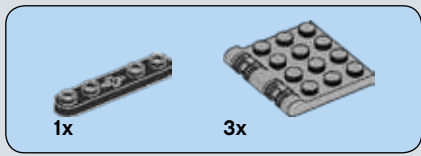

220

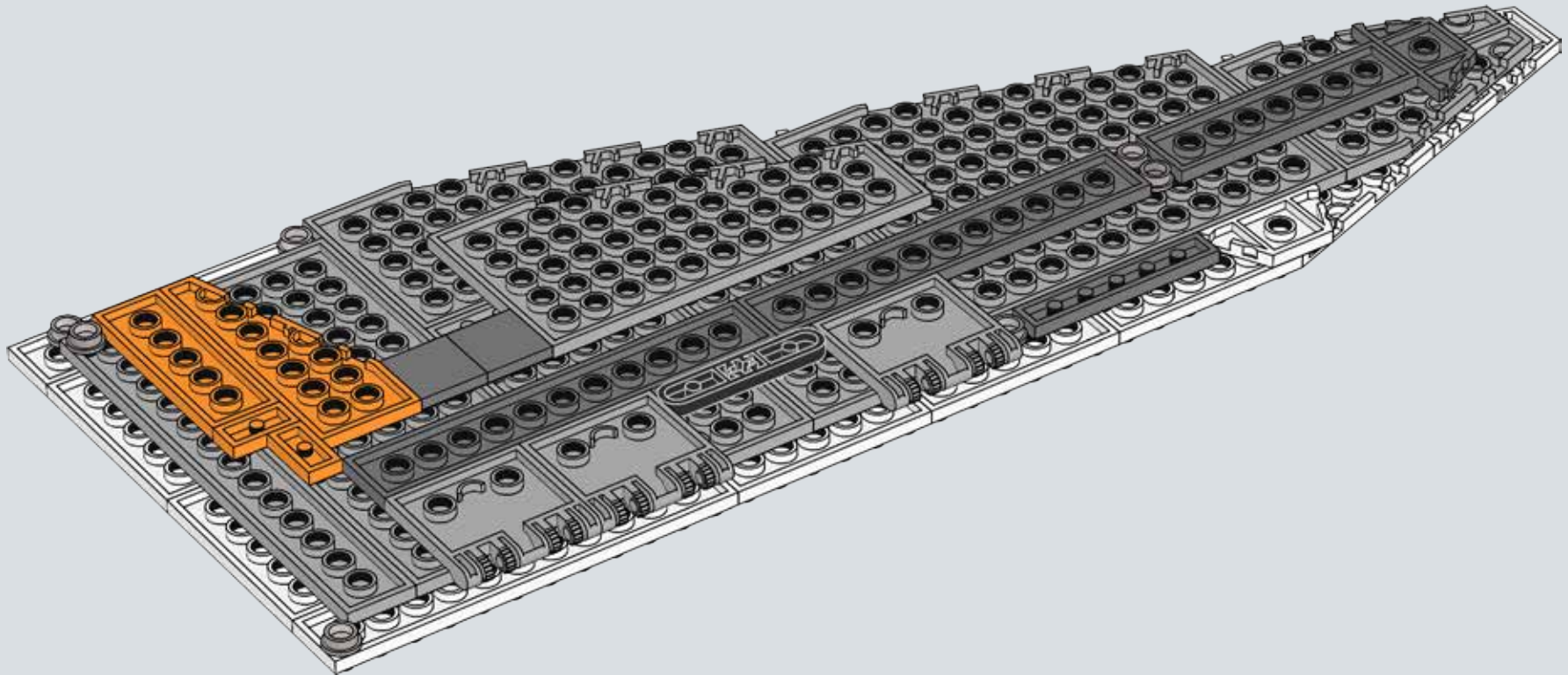

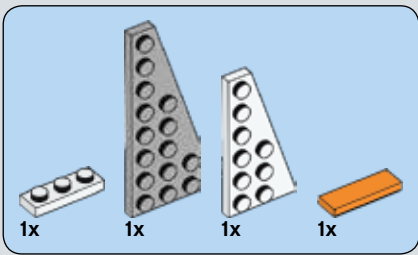

221

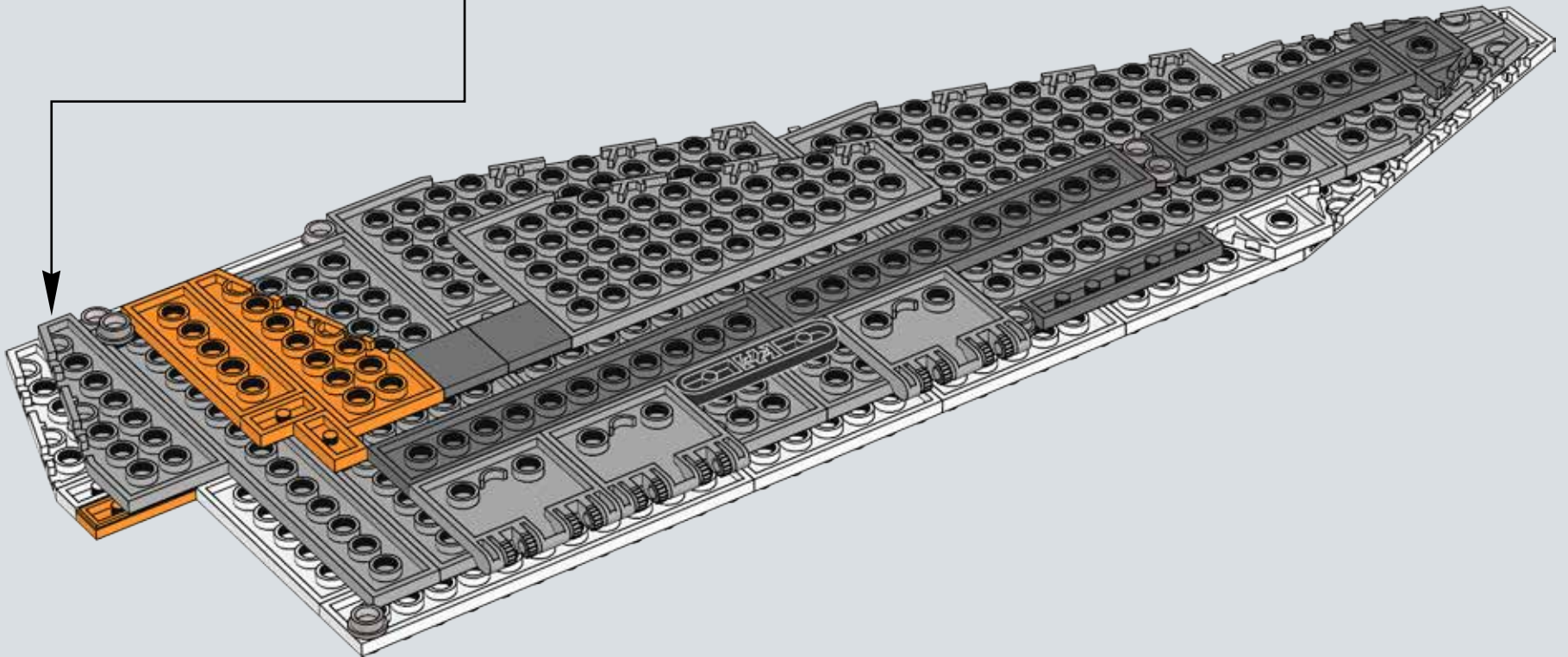
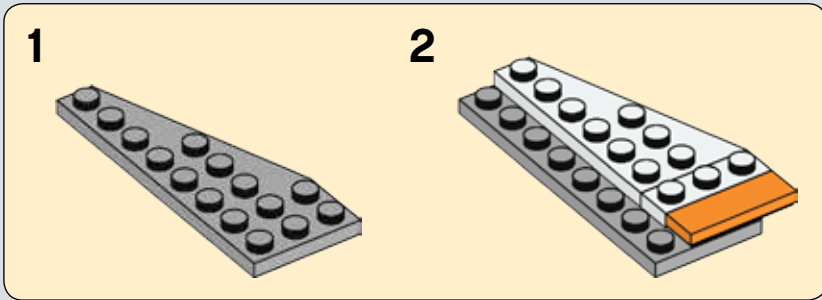

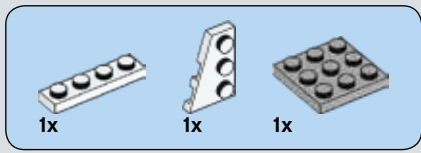

222

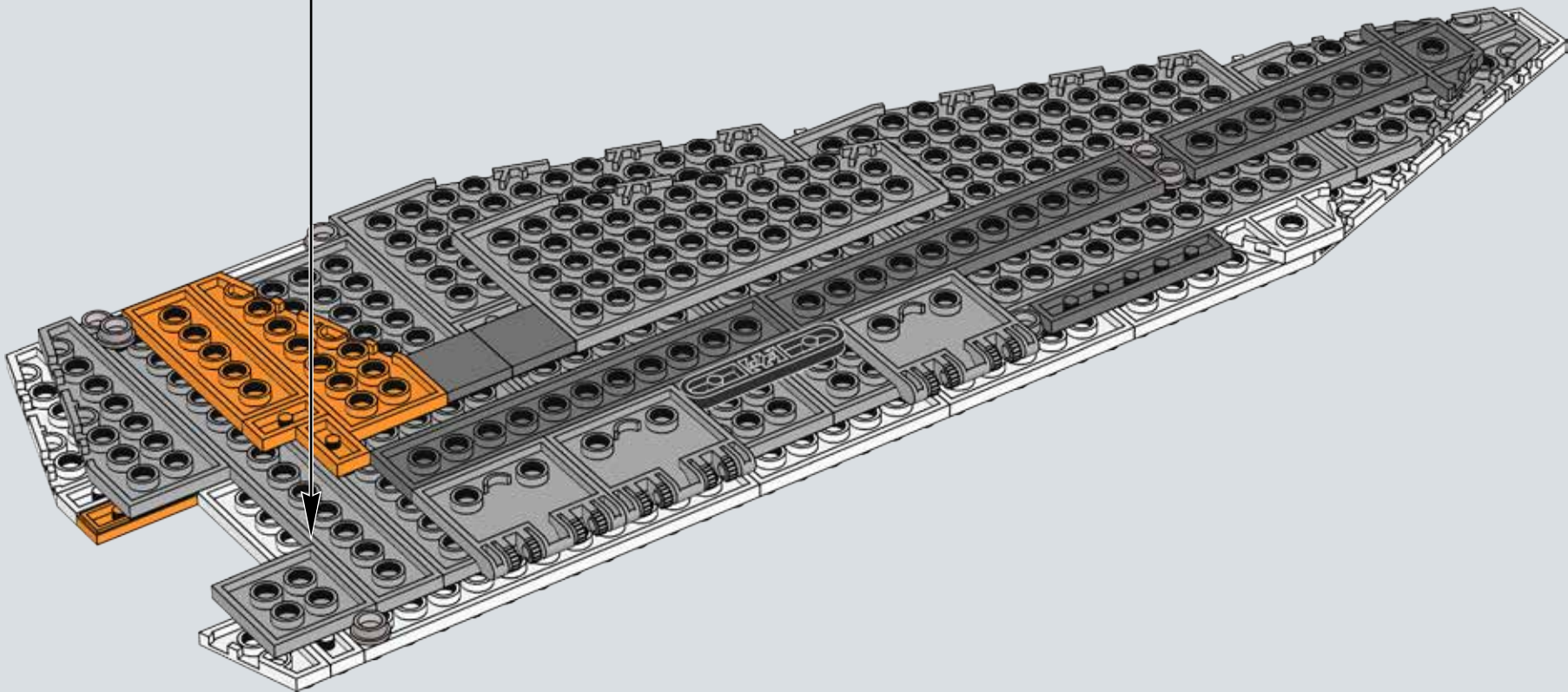
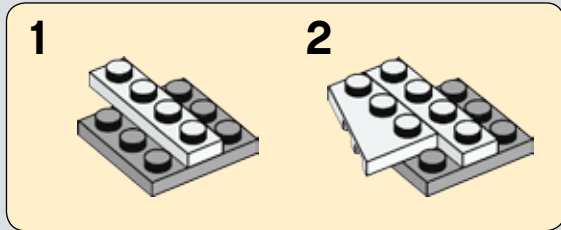



223

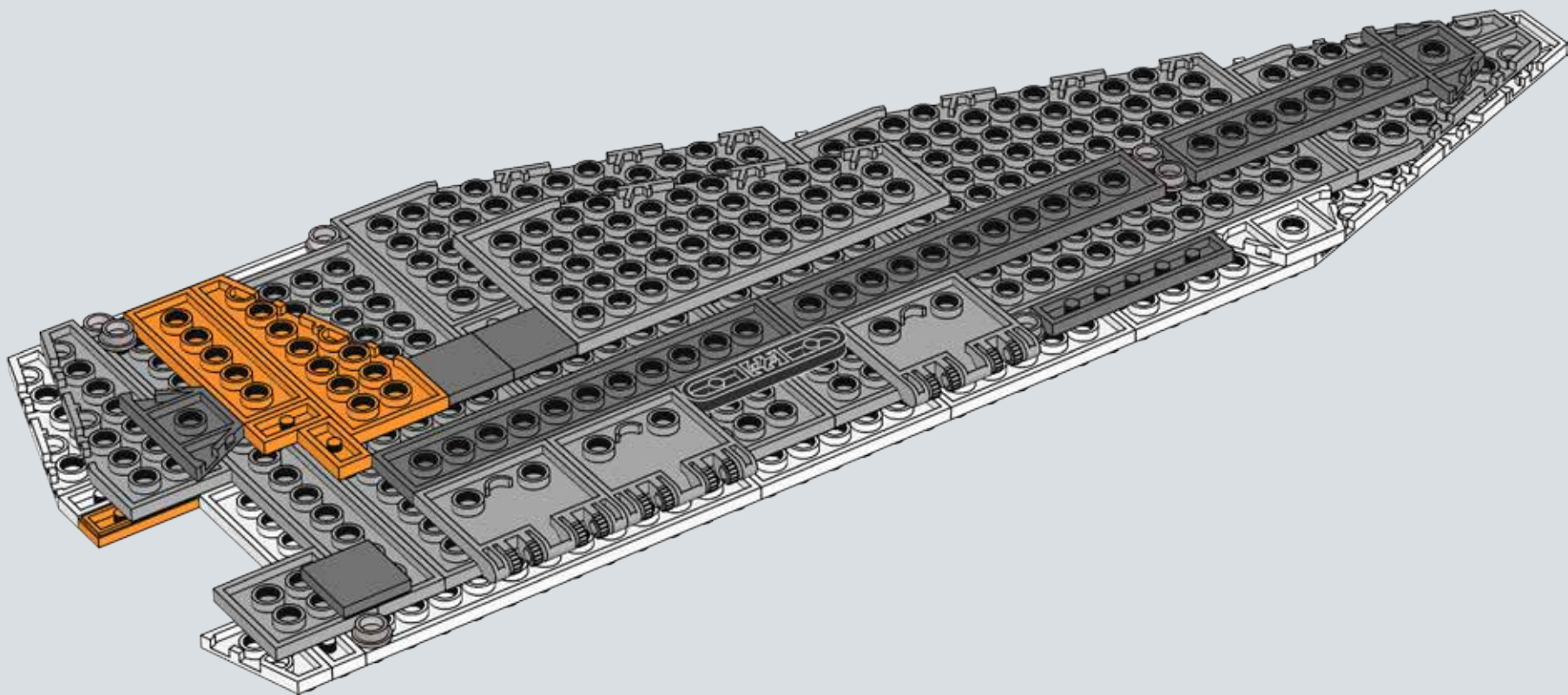

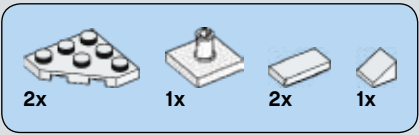

224

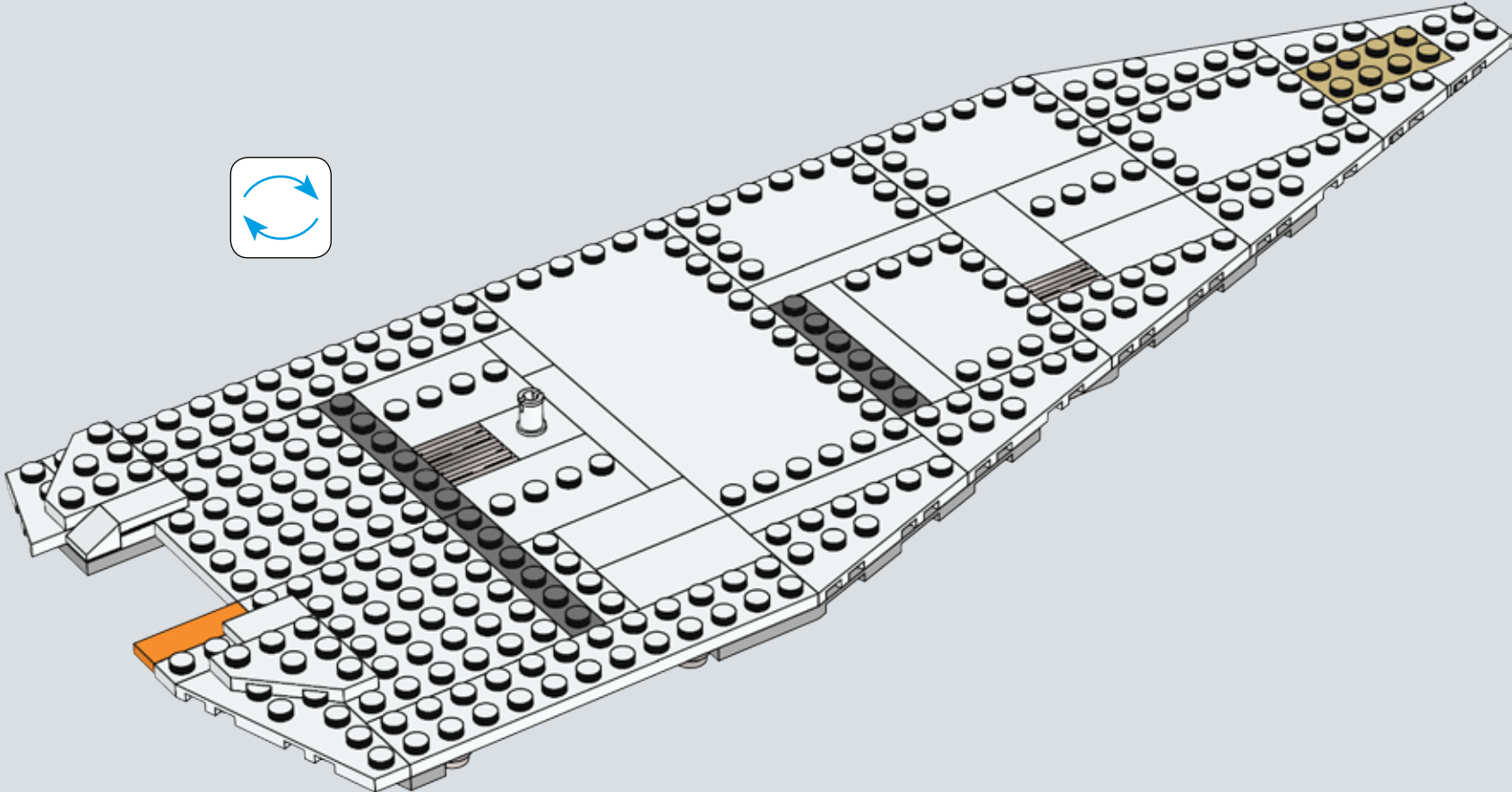

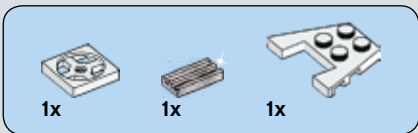

225

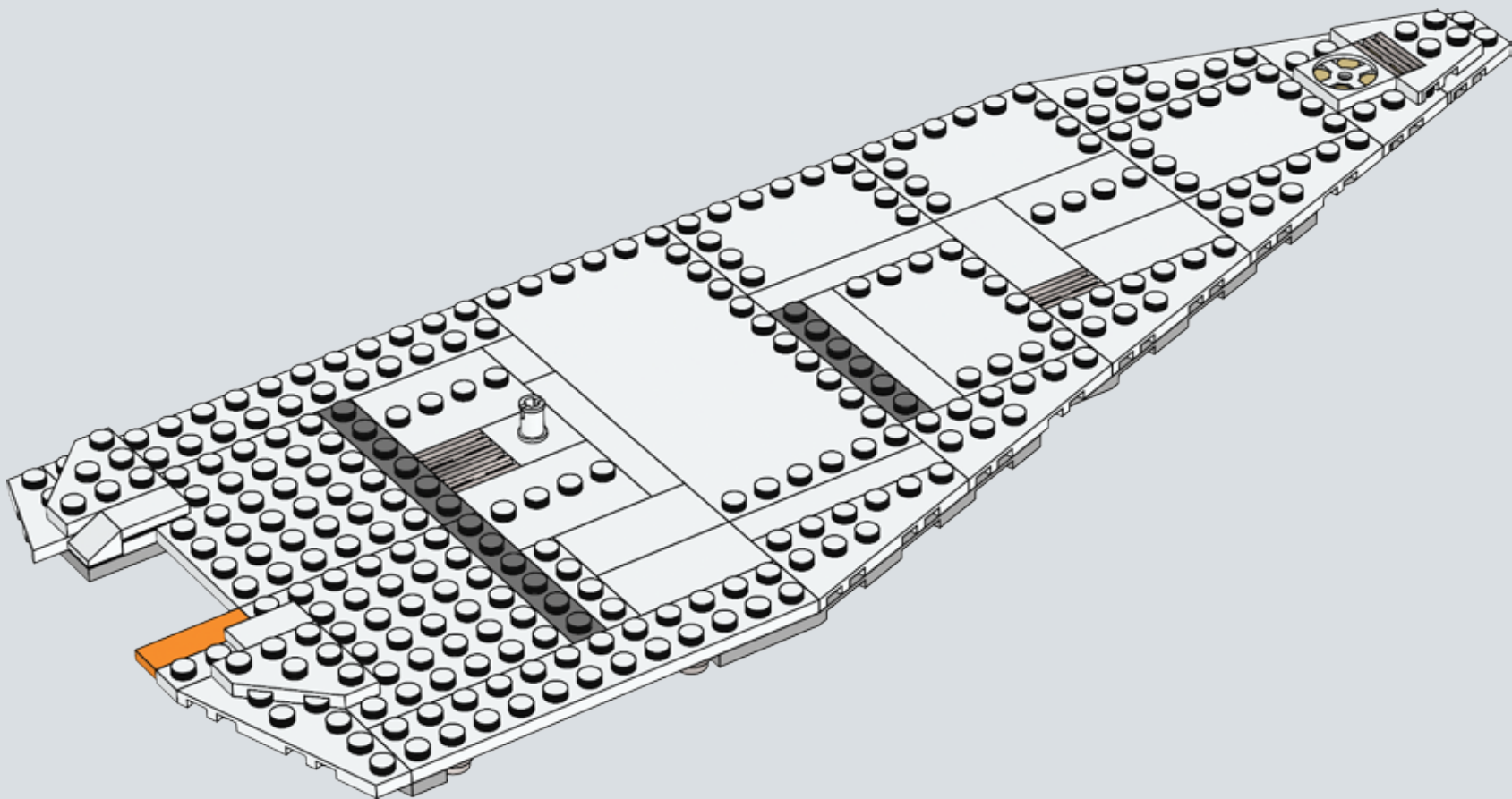



1x

226

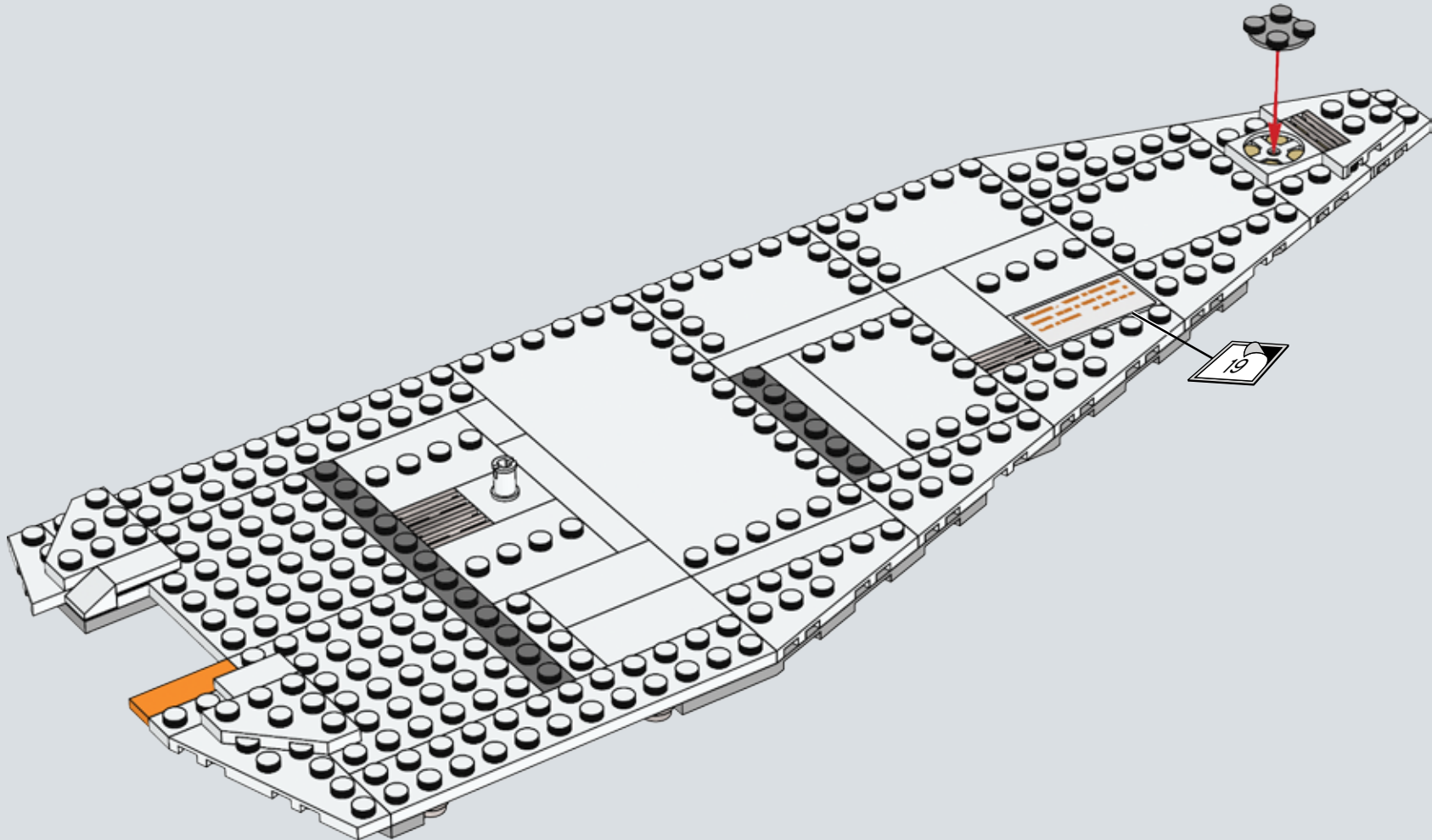

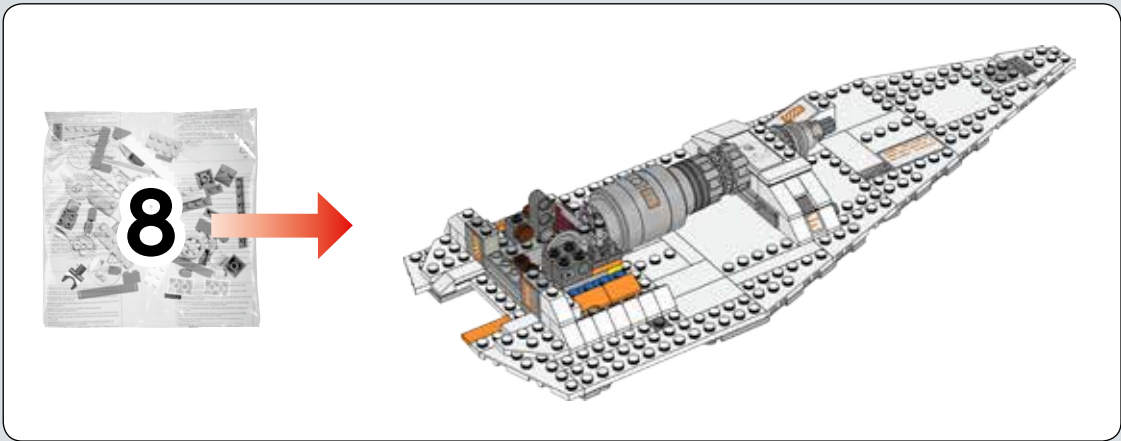

227

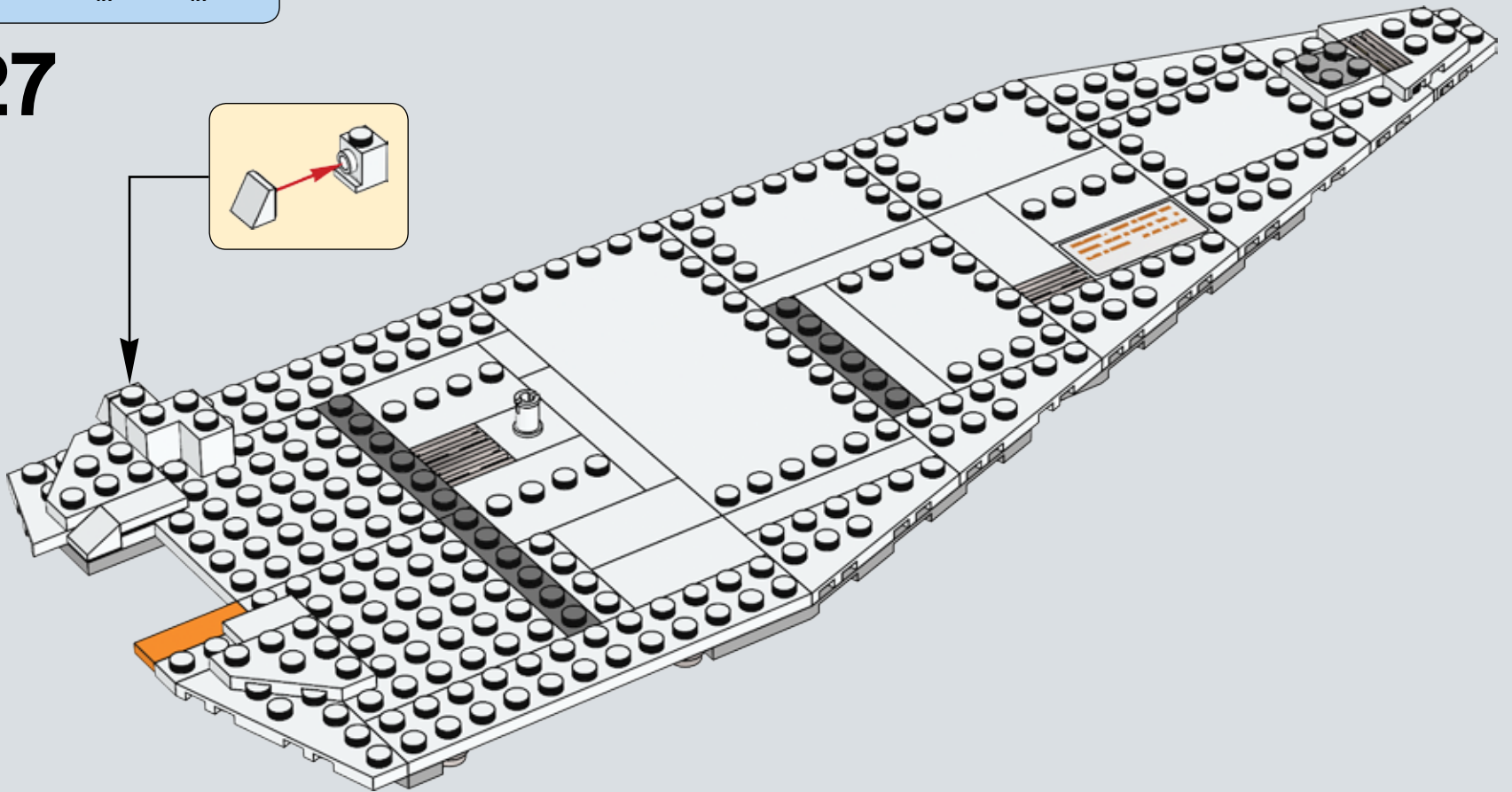

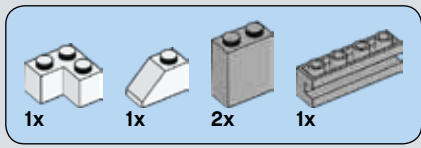

228

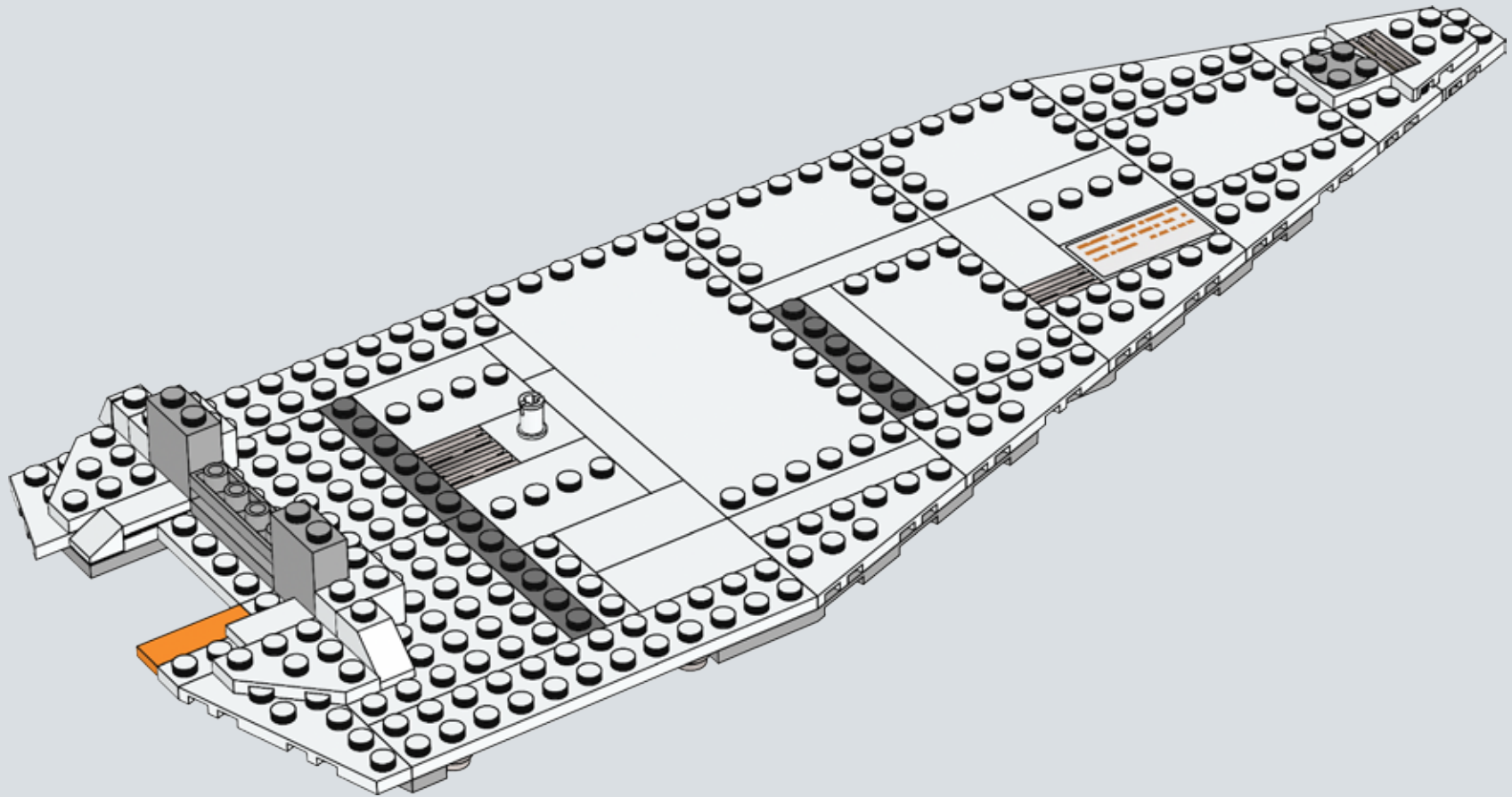



229

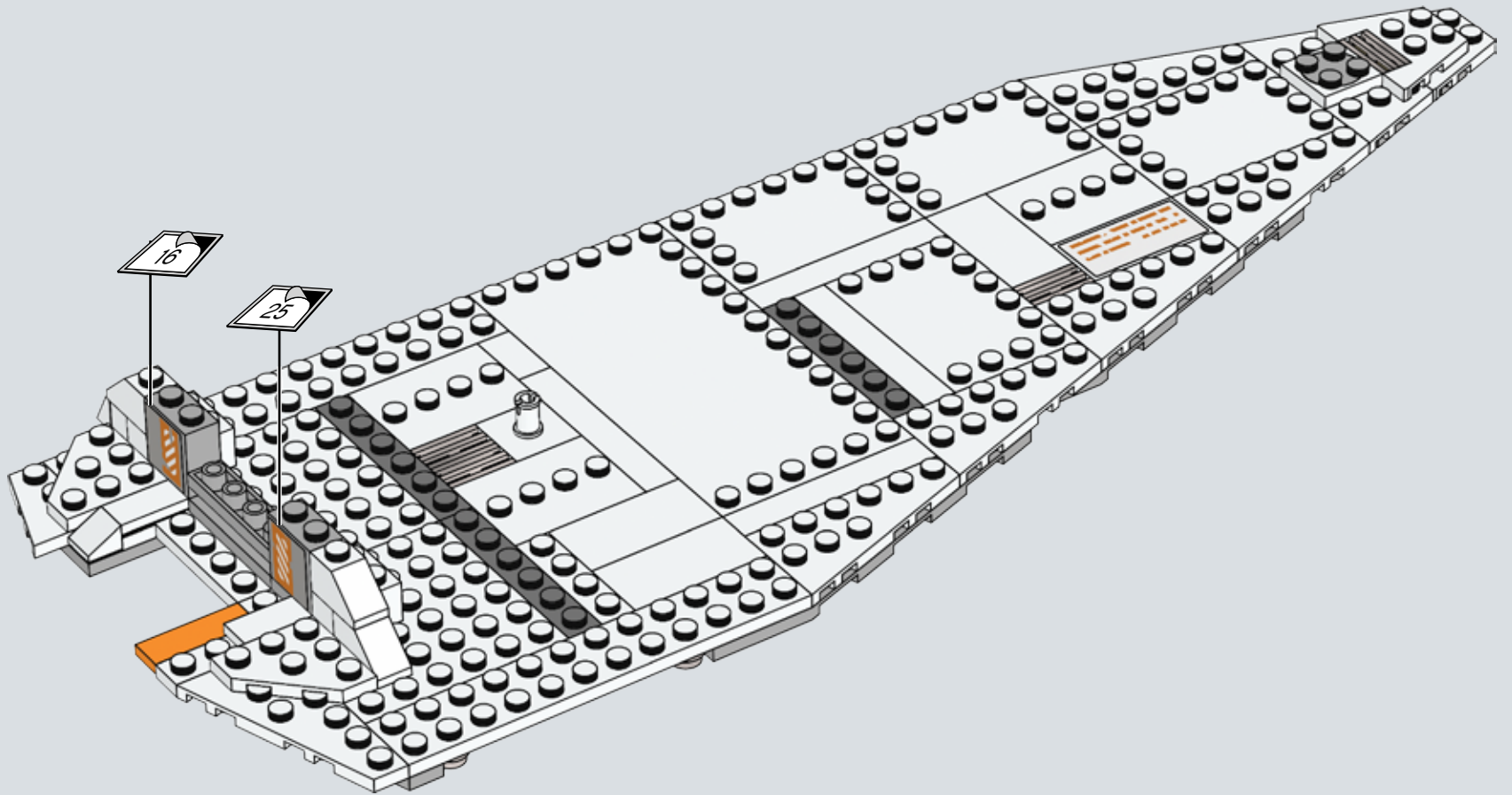



230

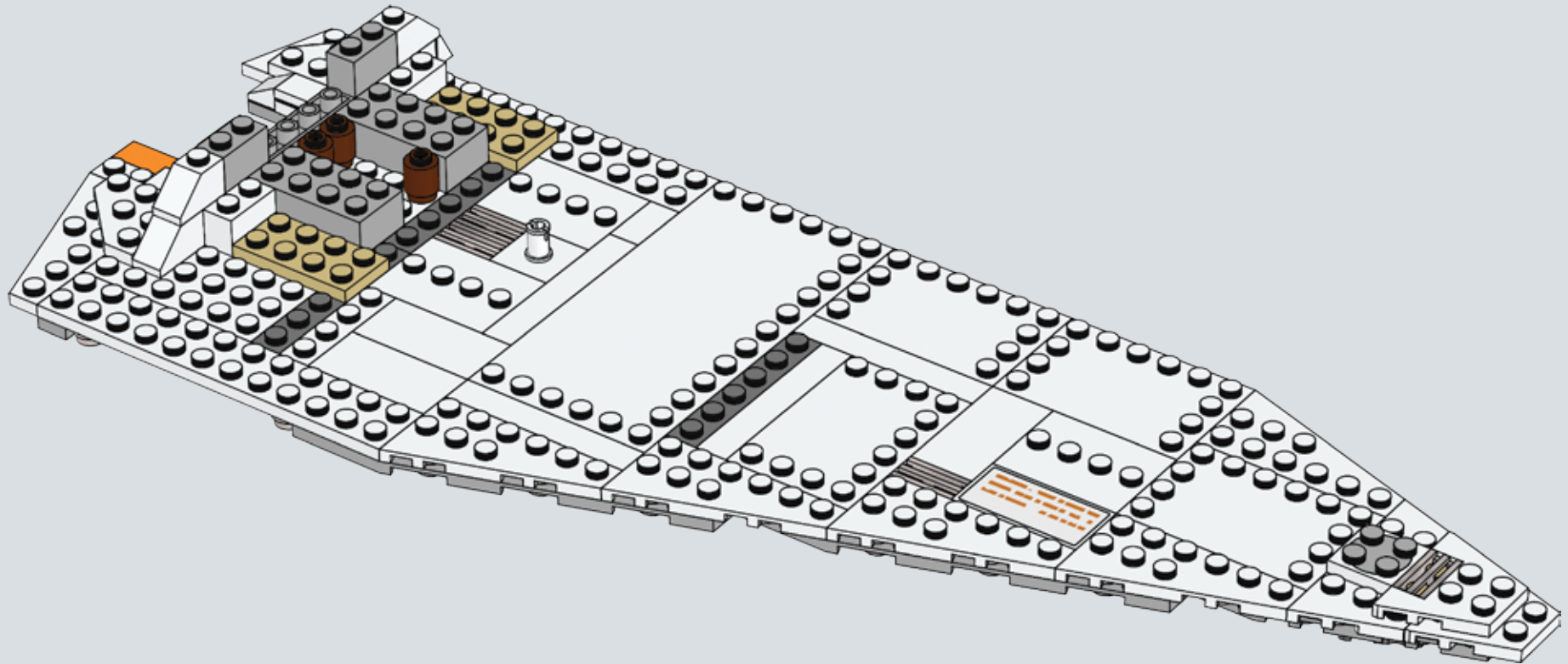



231

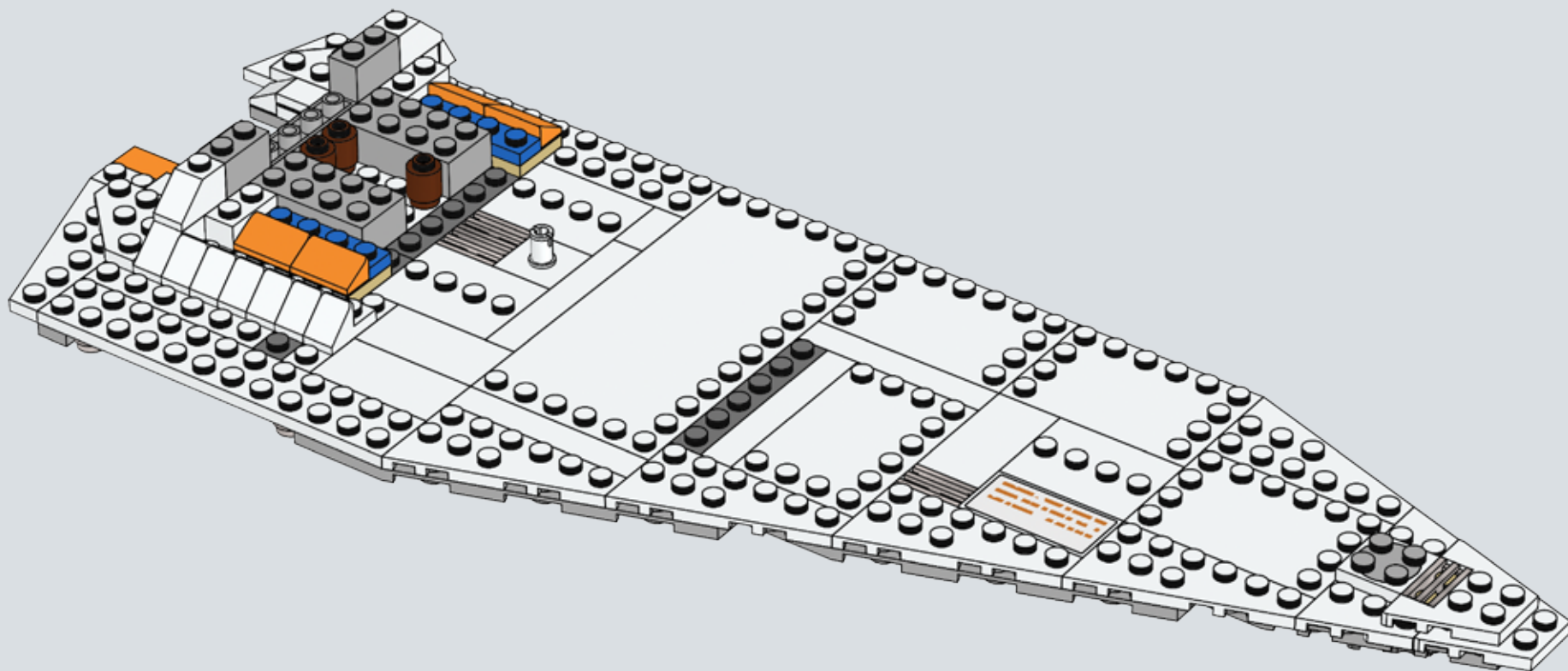

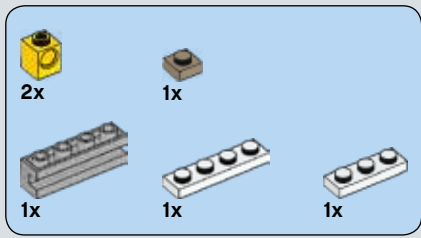

232

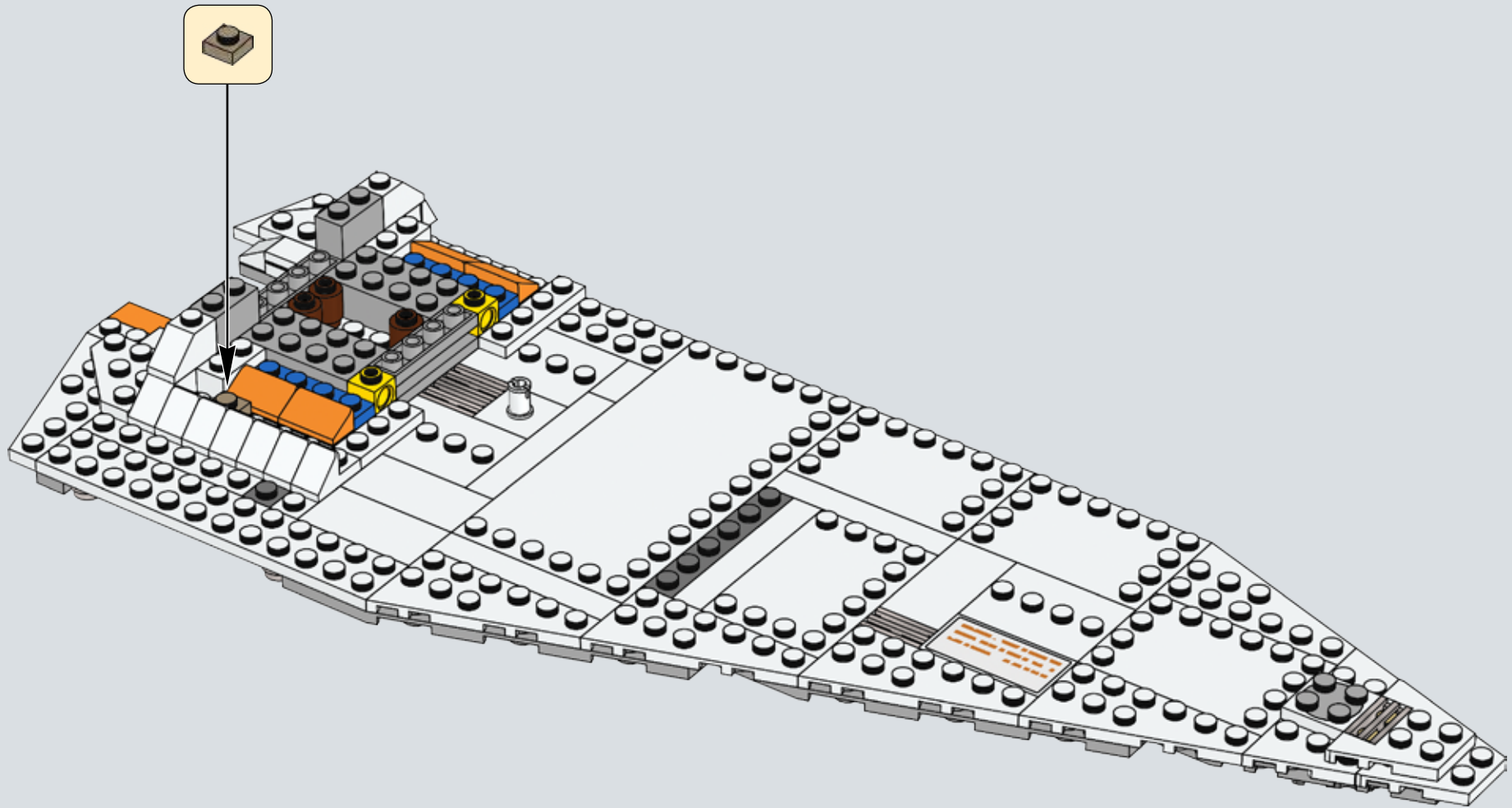



233

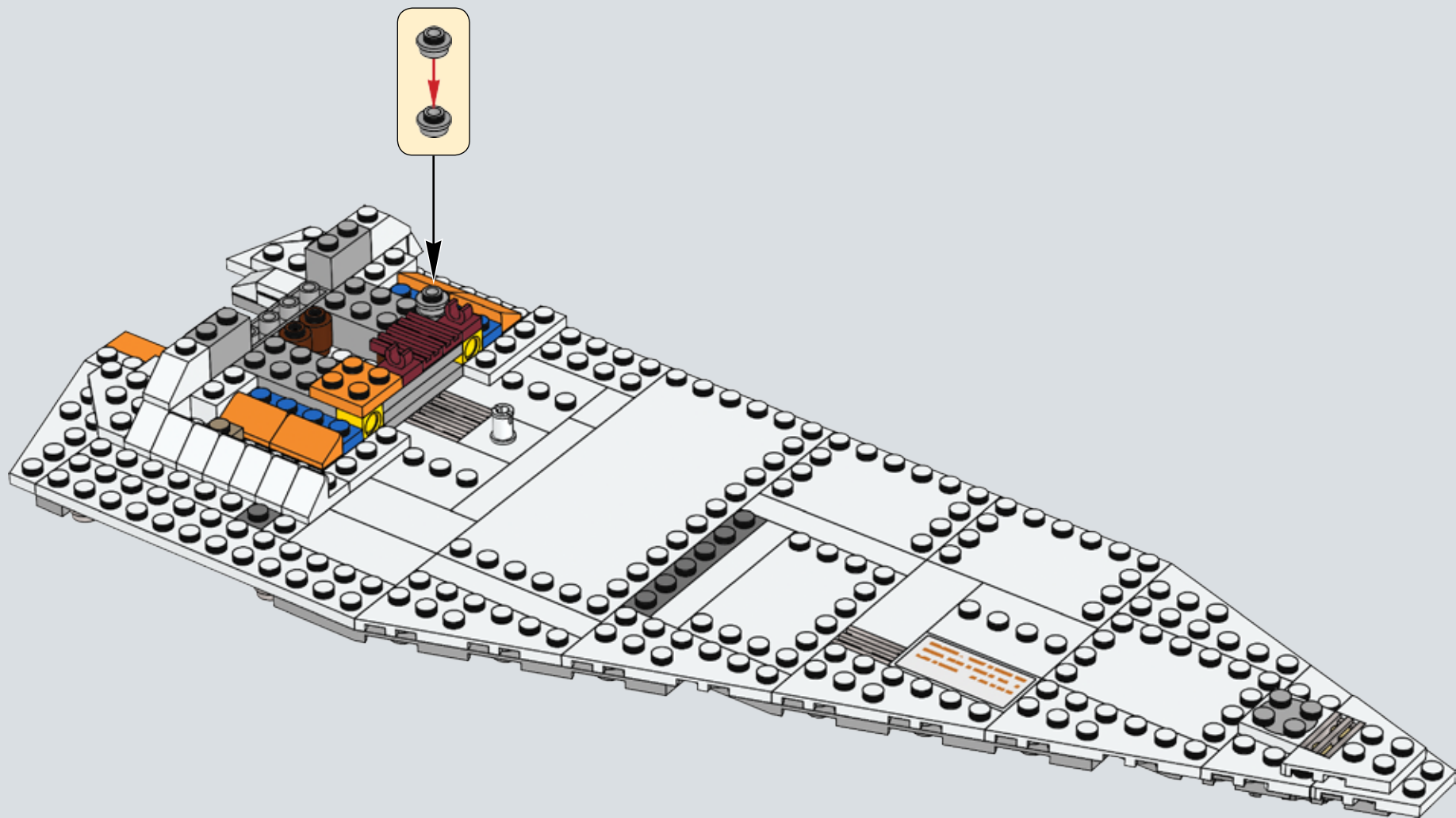



2x

234

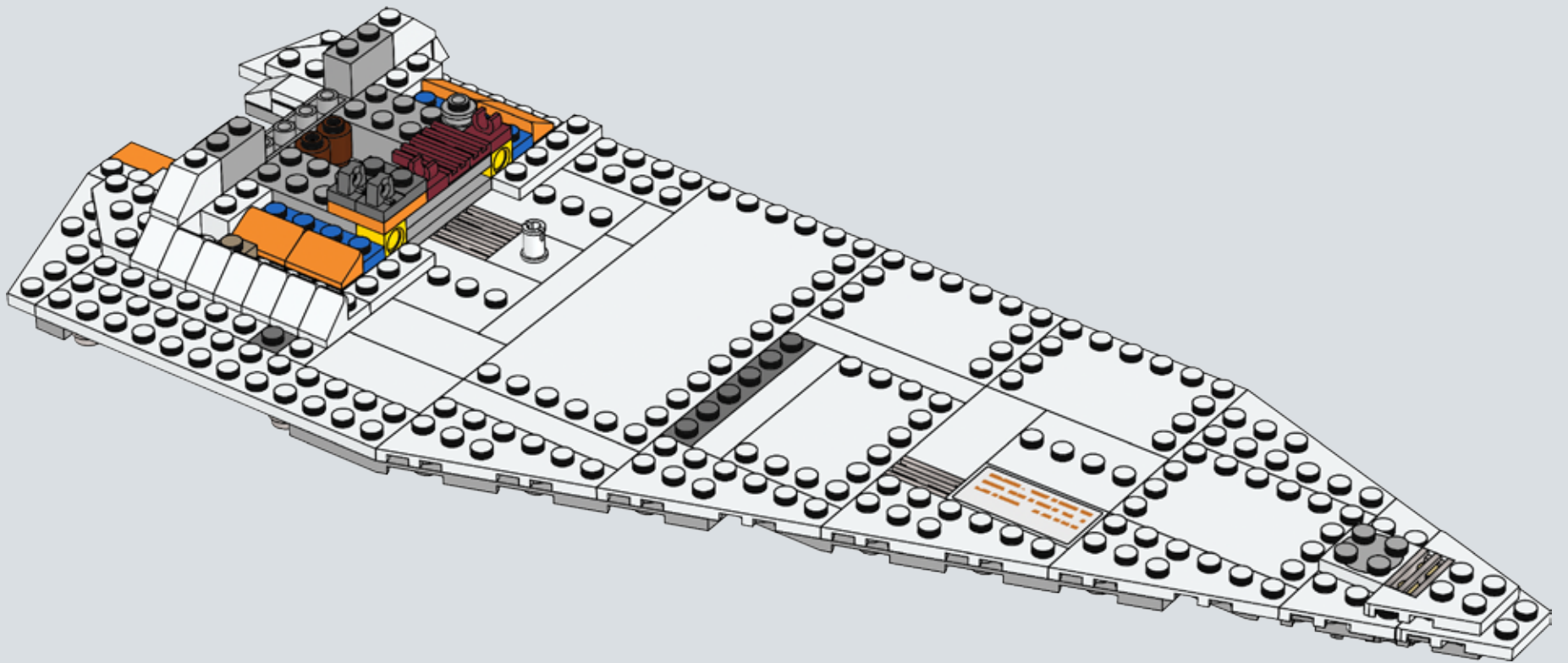

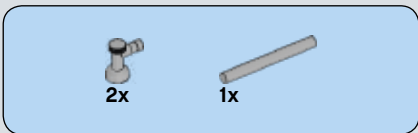

235

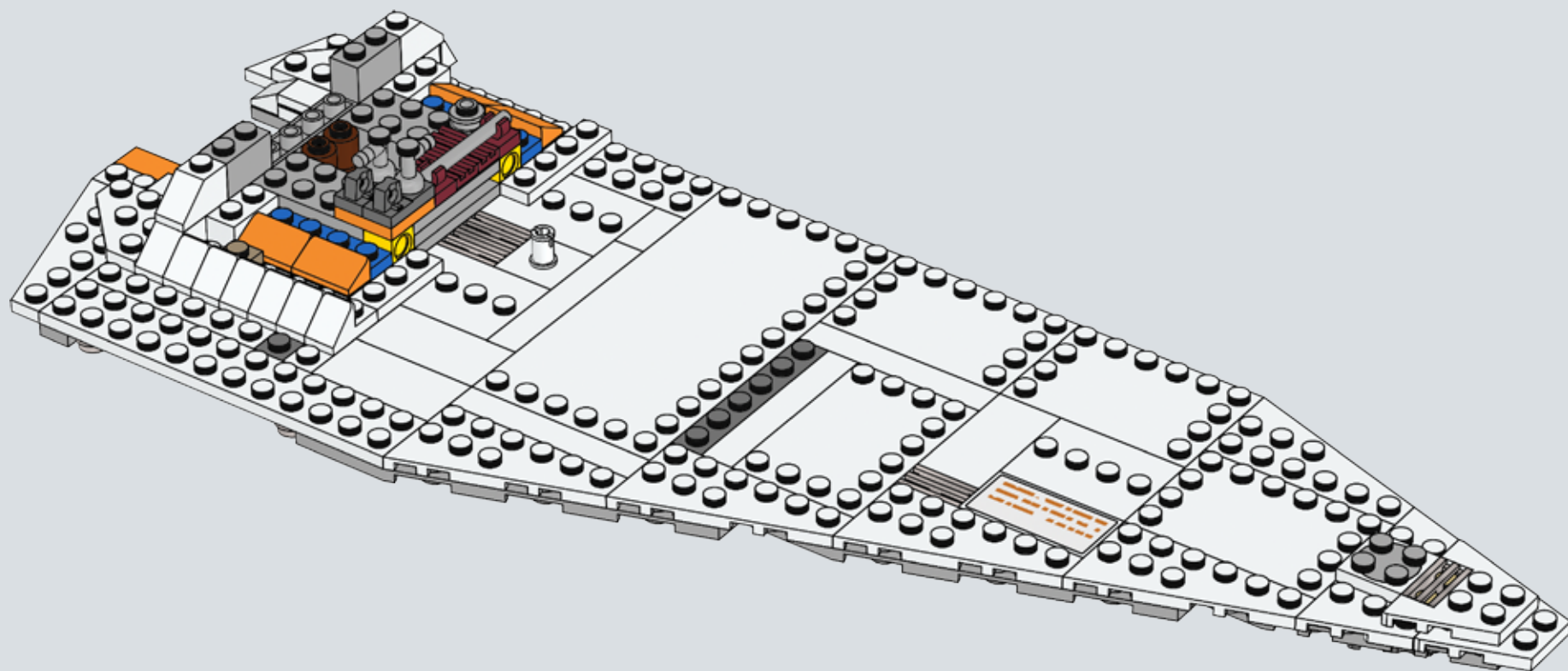

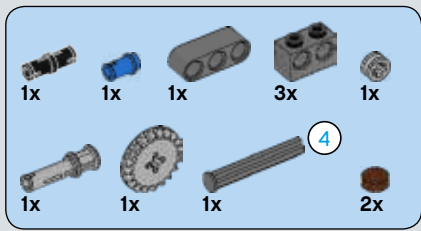

236

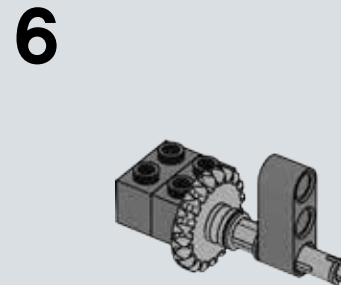
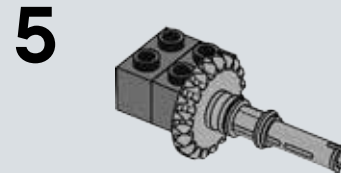
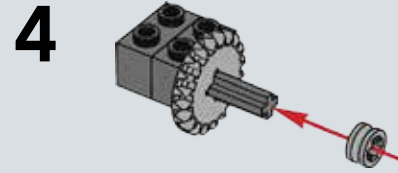
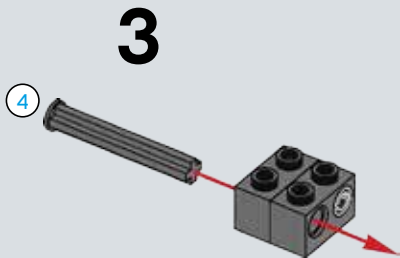
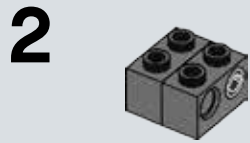
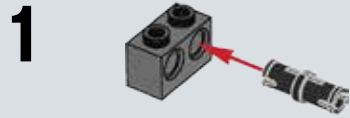

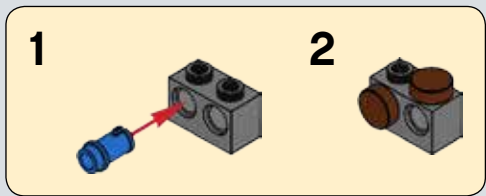

7

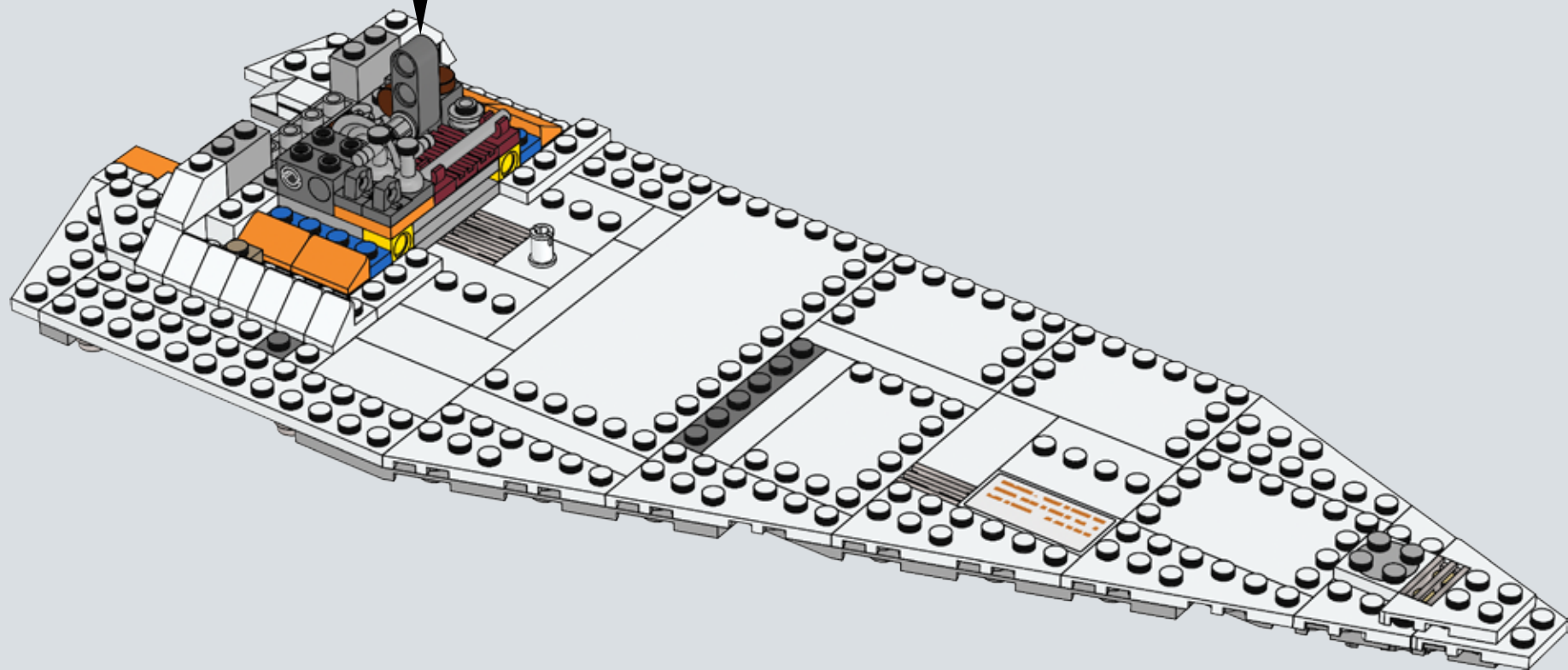
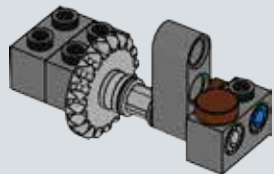

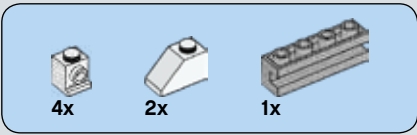

237

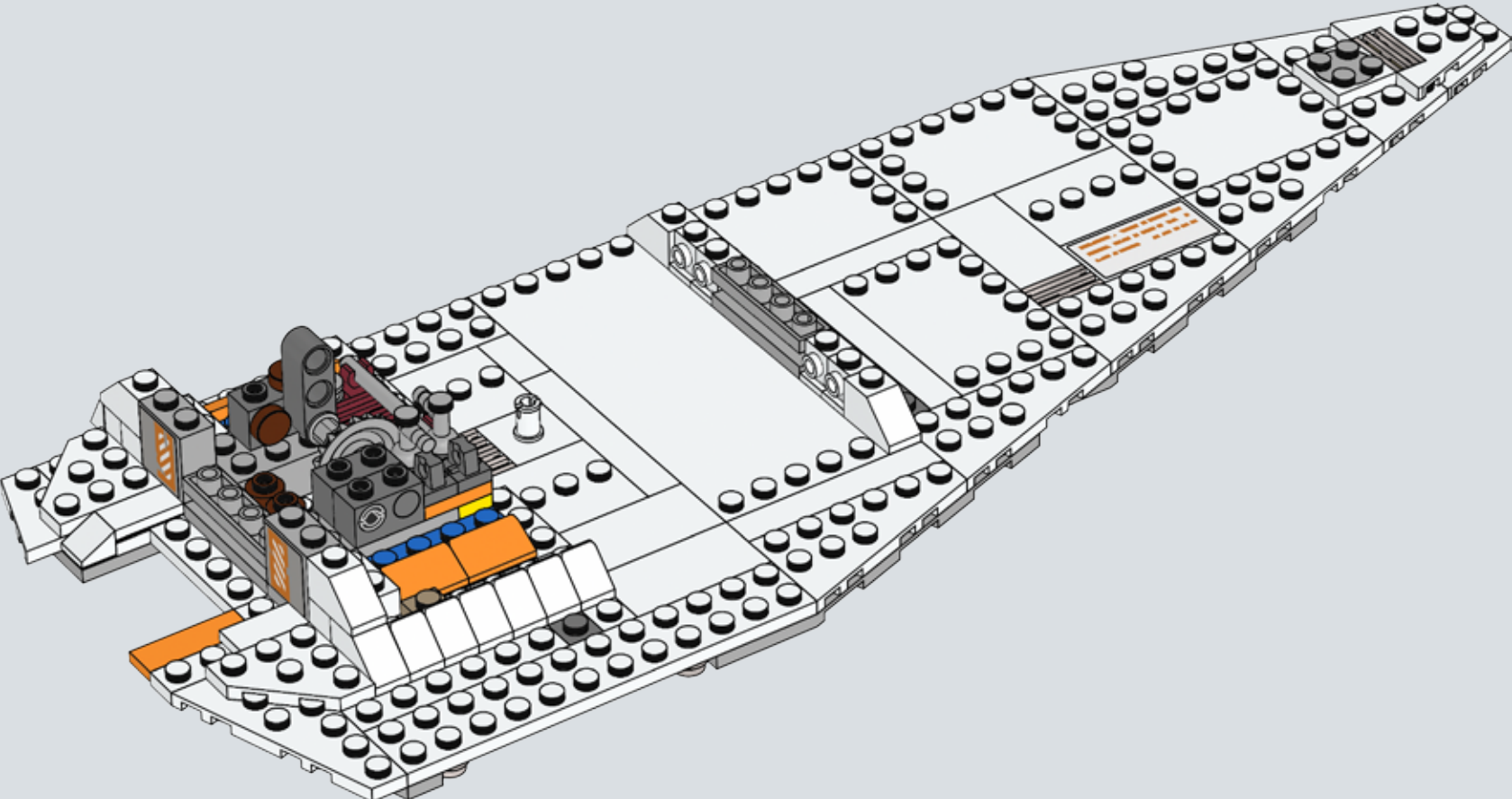

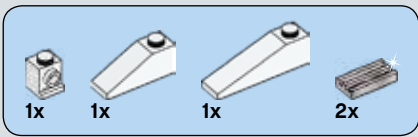

238

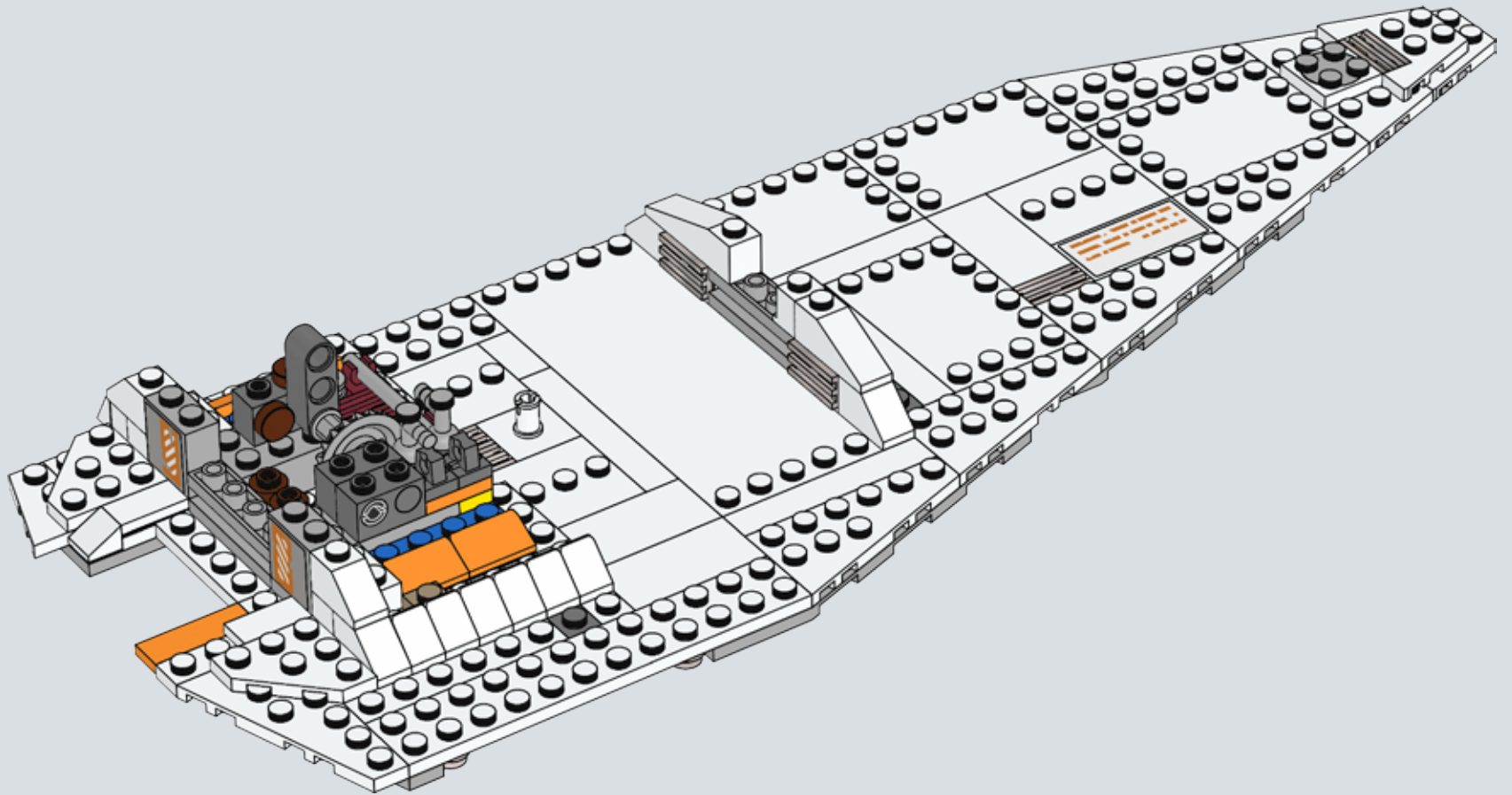



239

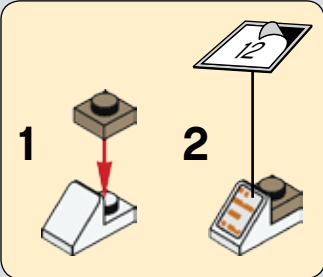
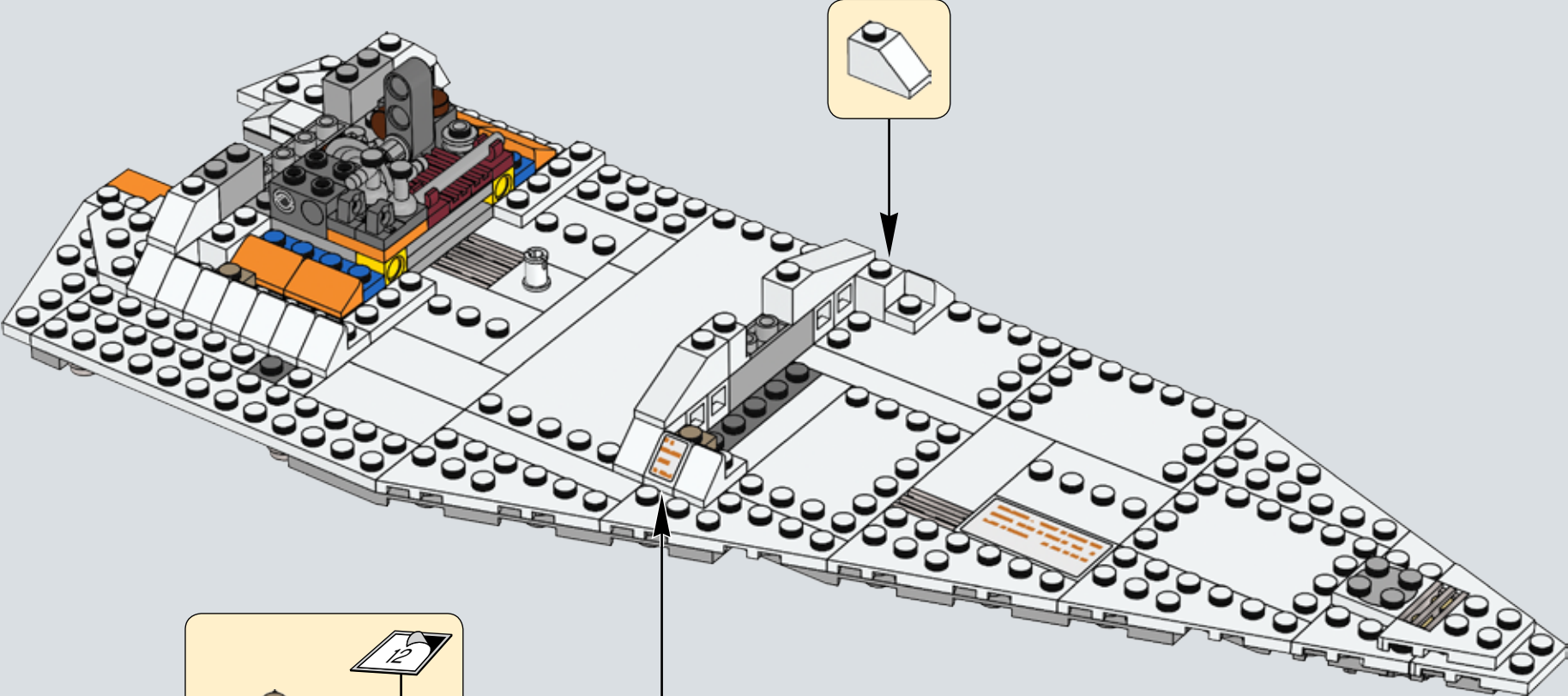

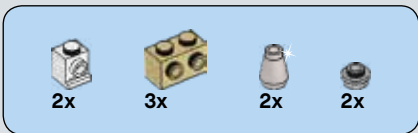

240

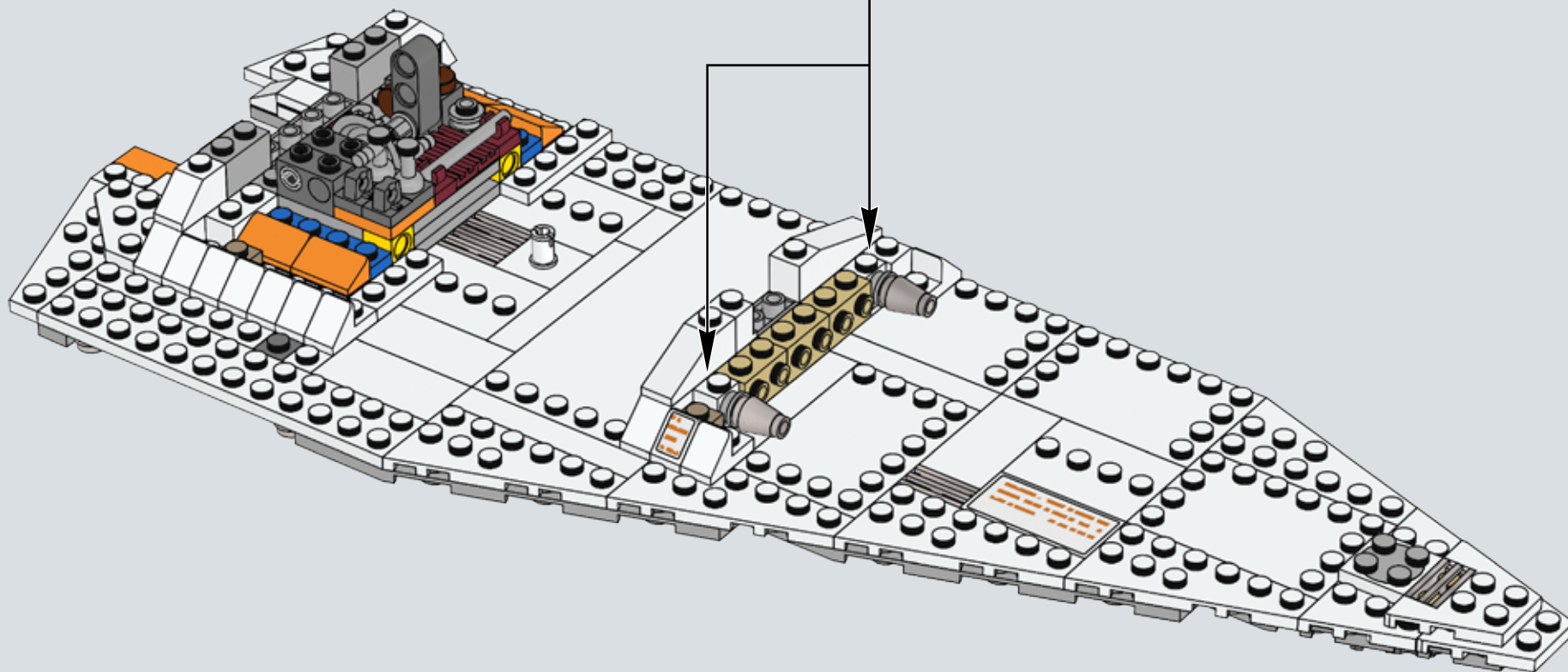
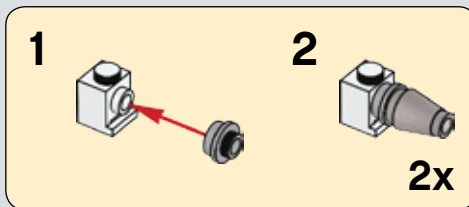

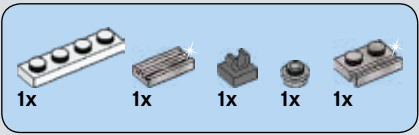

241

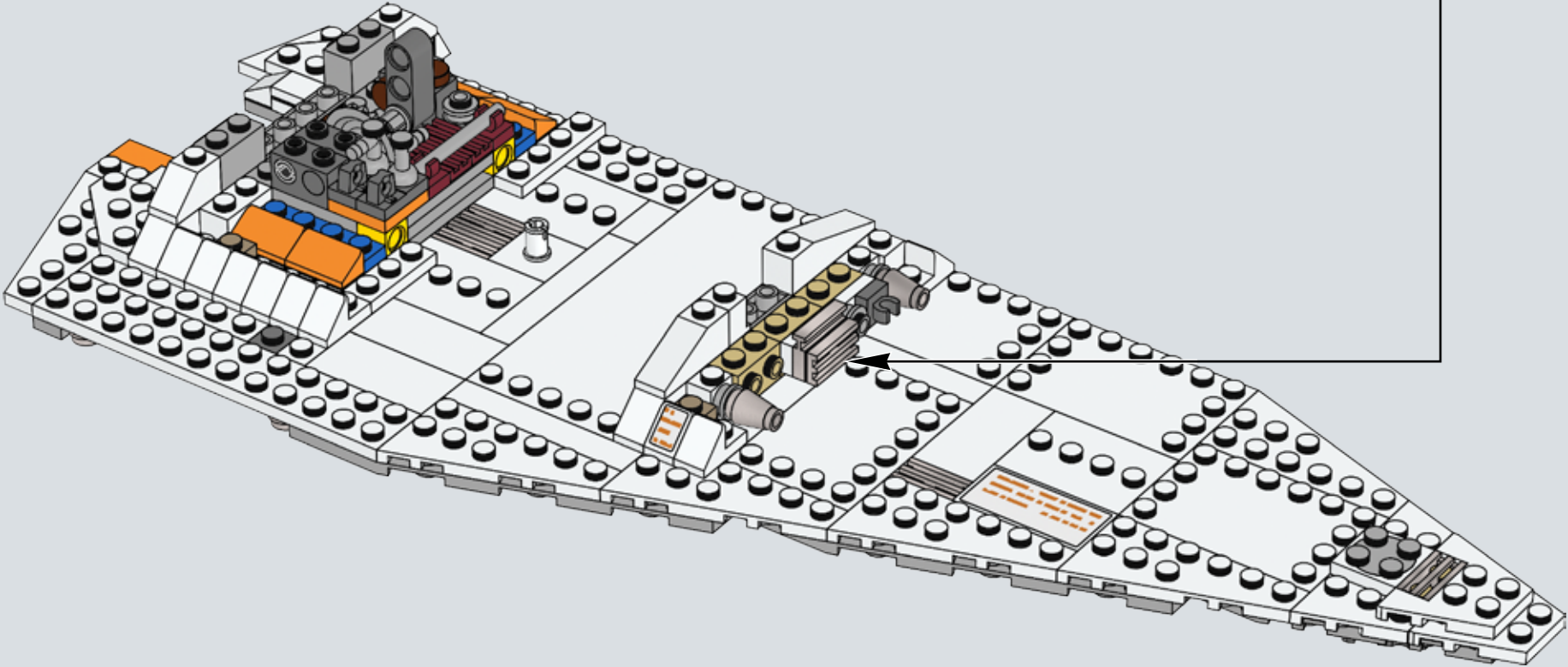
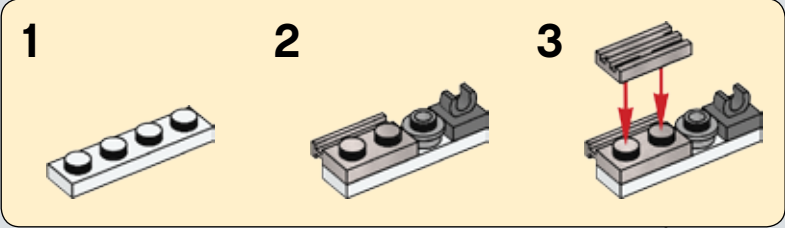



2x



1x

242

1

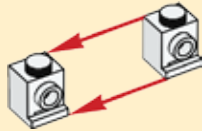

2

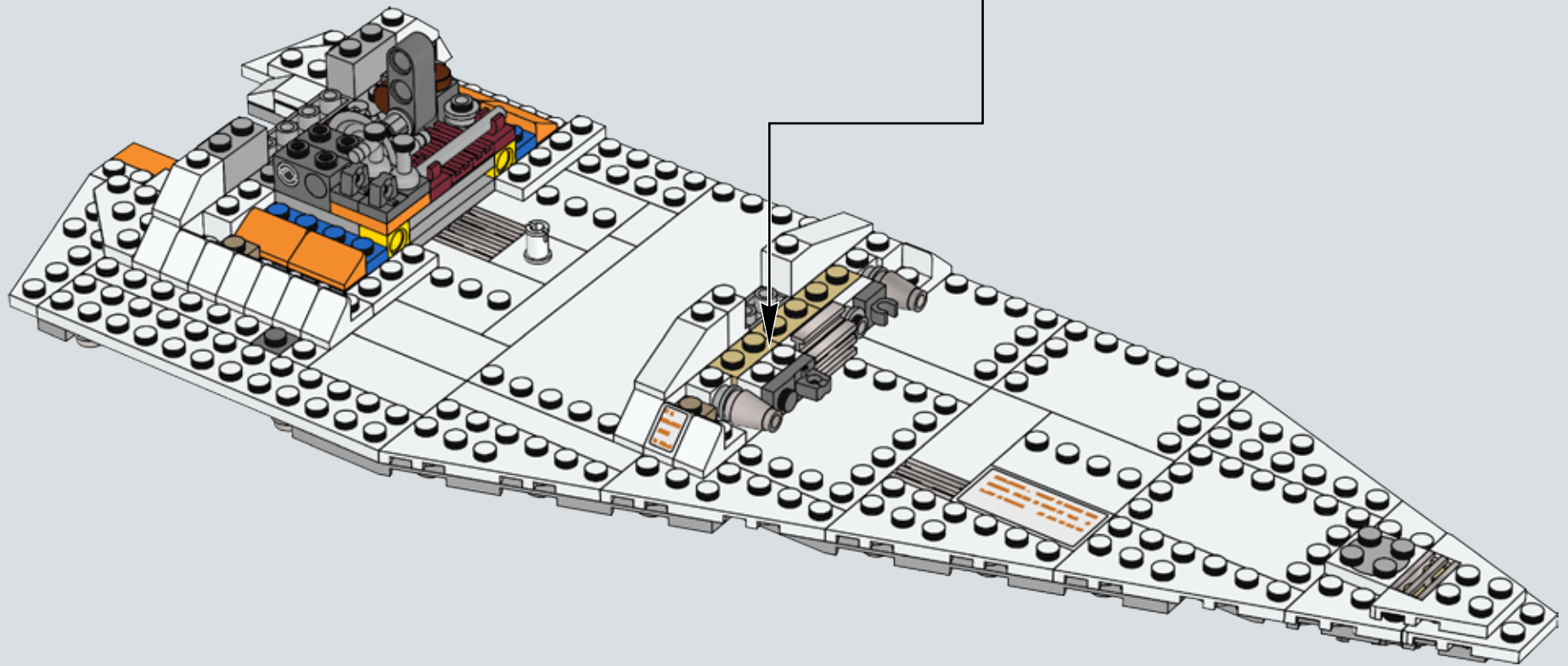



243

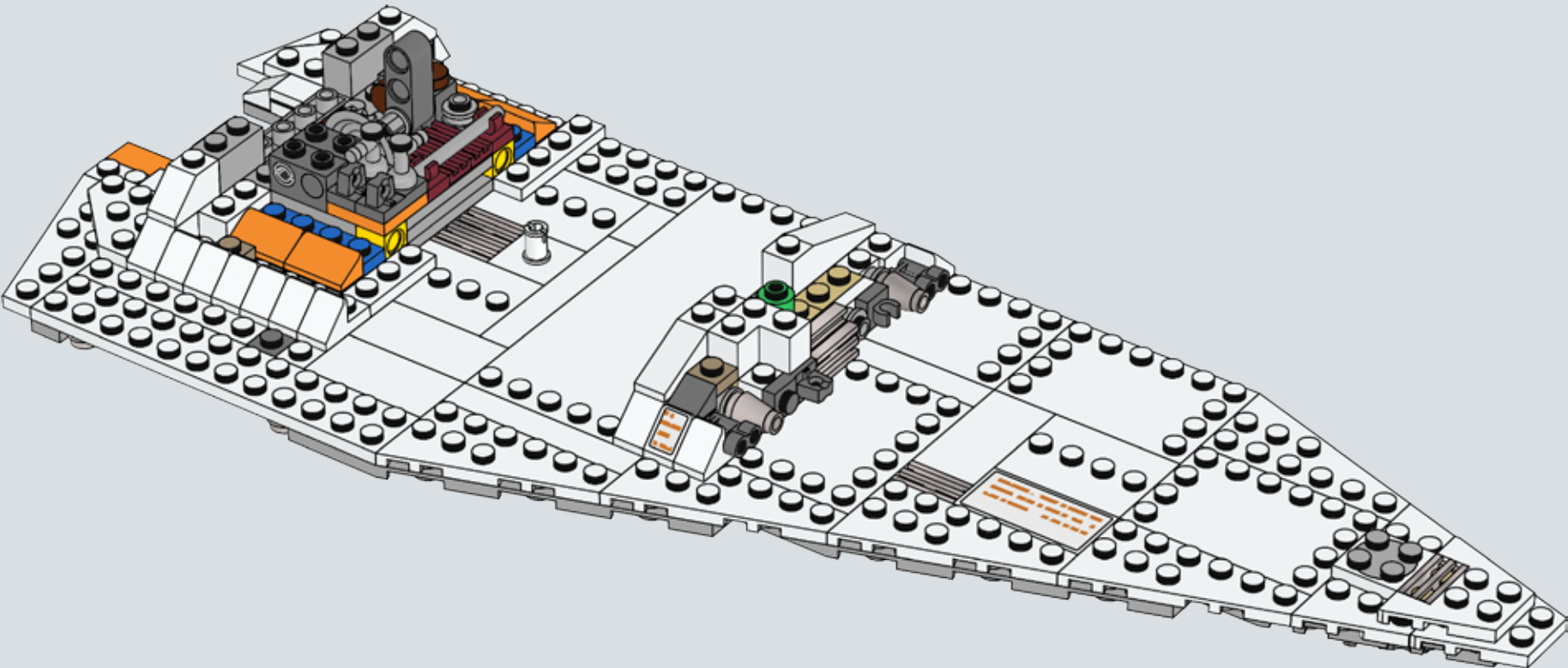

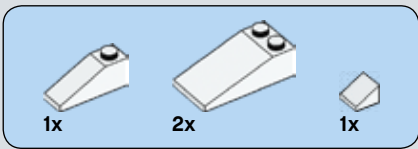

244

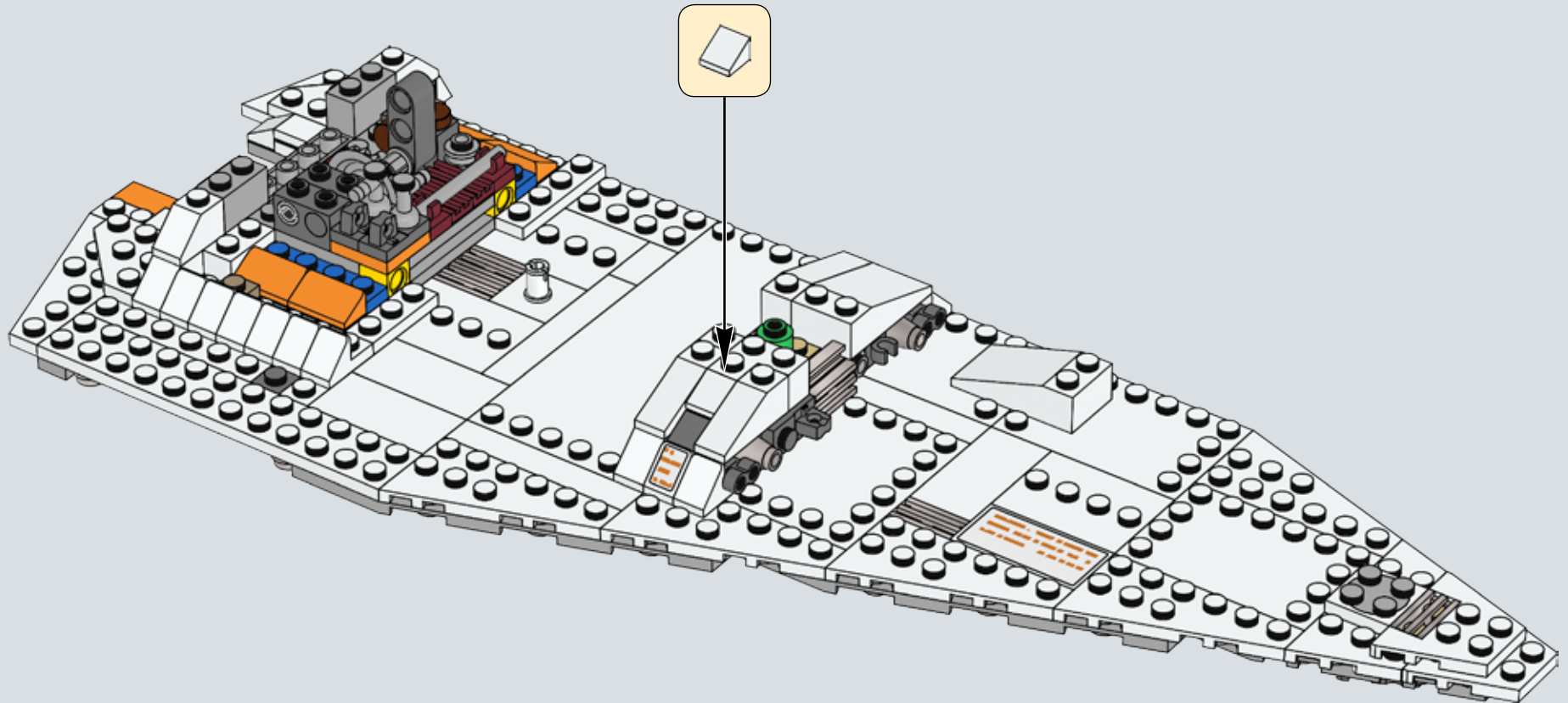

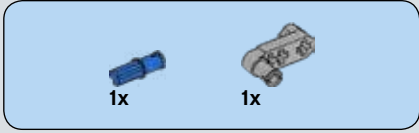
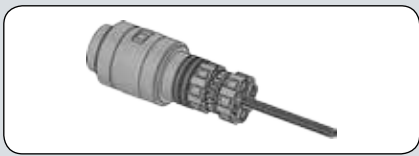

245

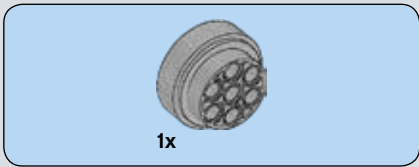
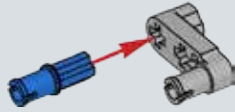

246

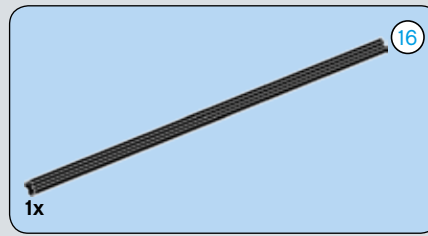
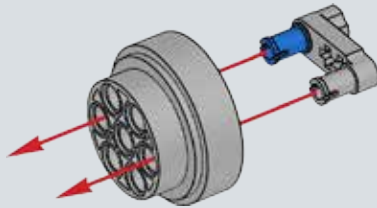

247

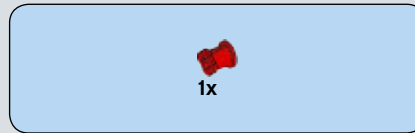
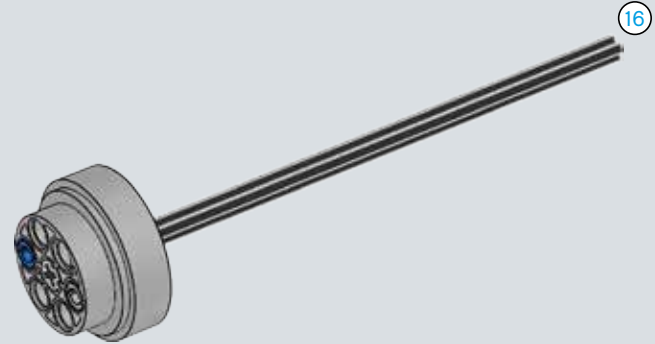

248

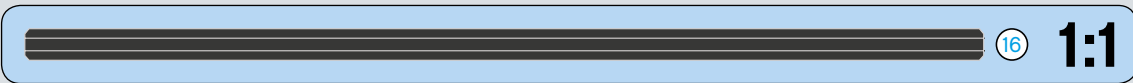
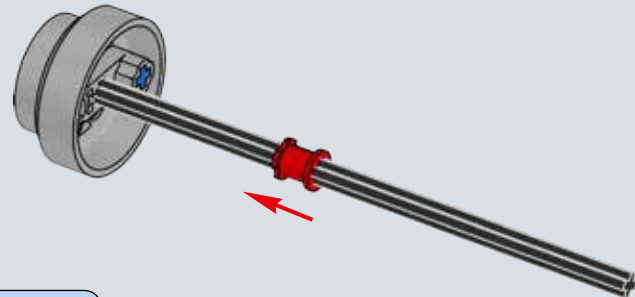

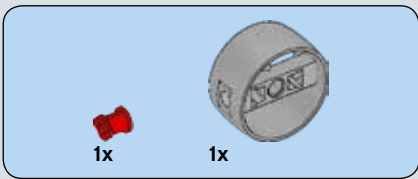

249

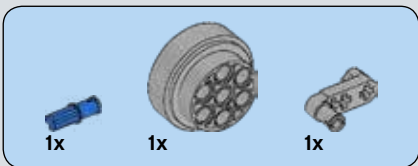
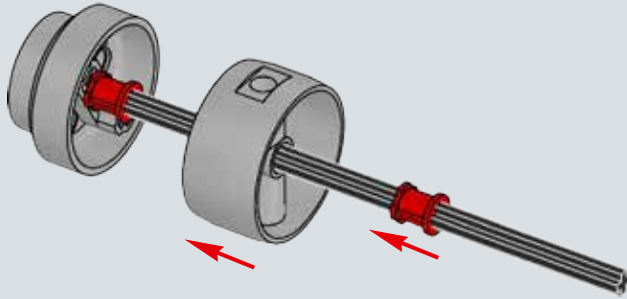

250

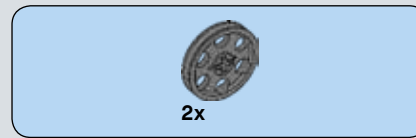
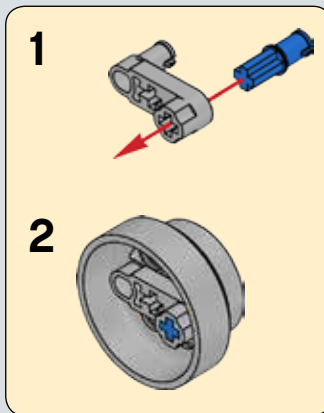
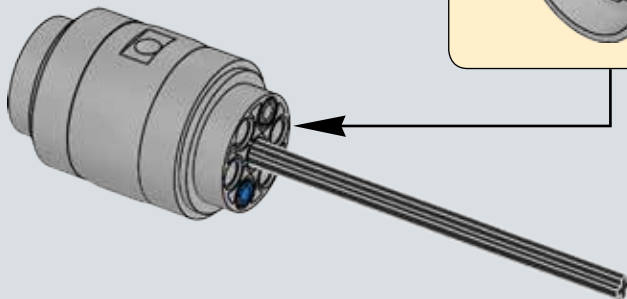

251

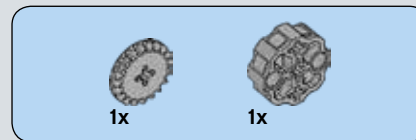
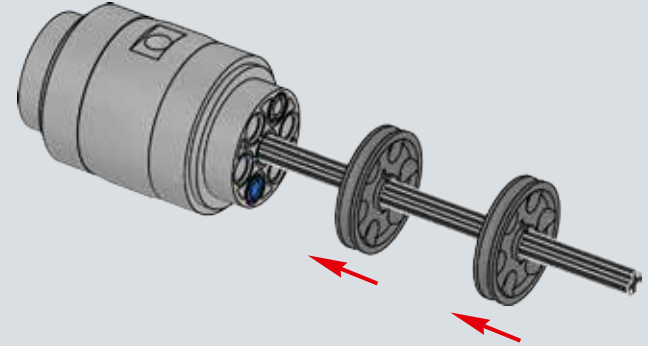

252

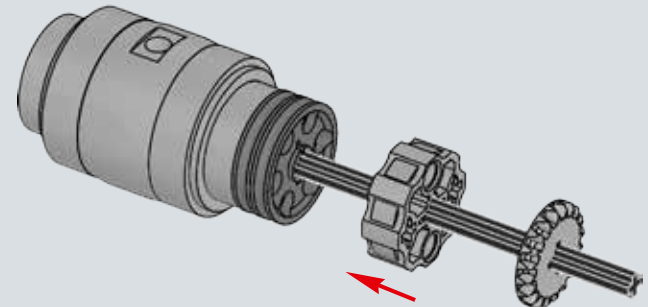

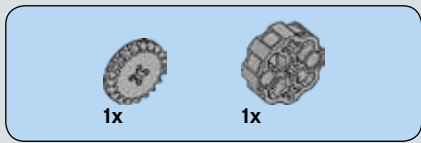

253

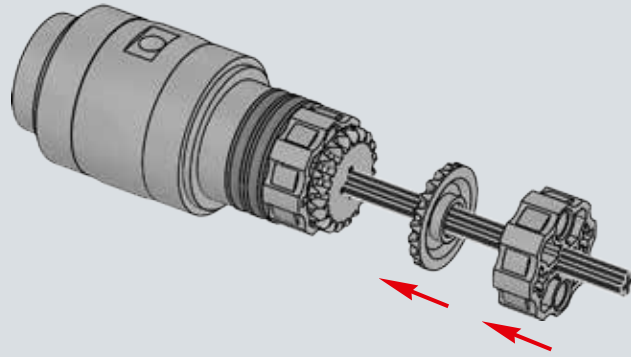

254

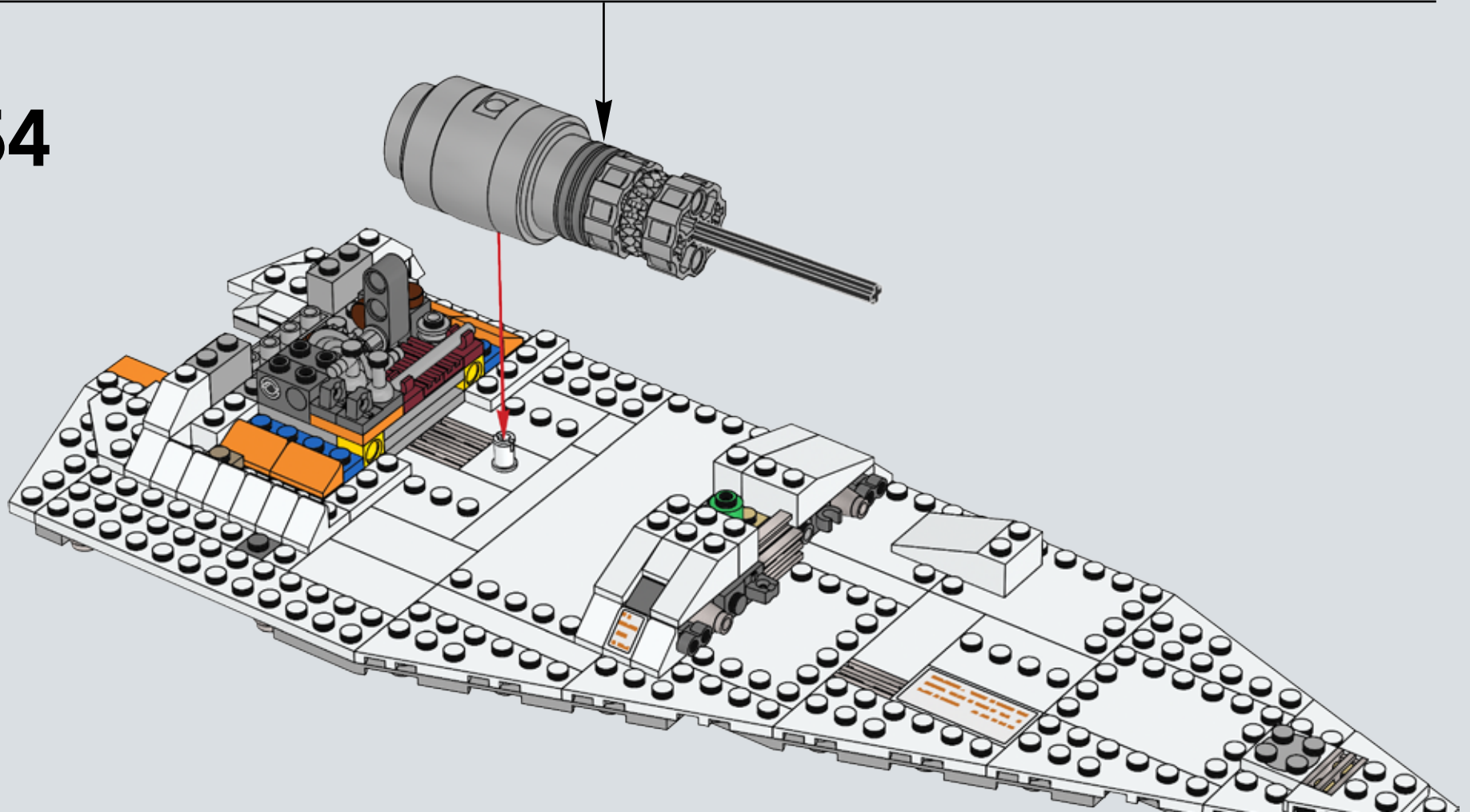

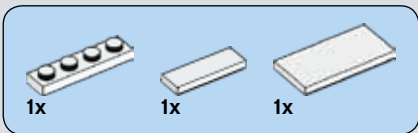

255

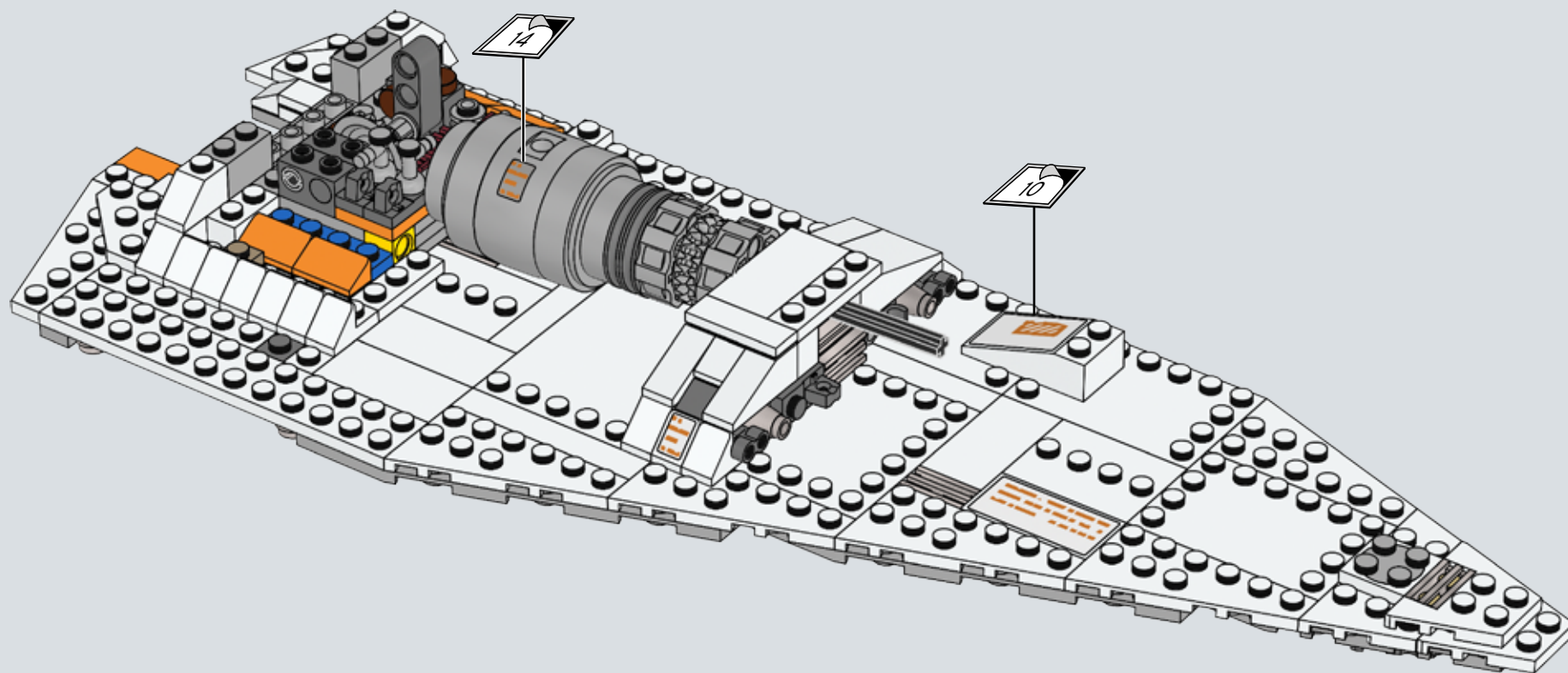



1x



1x

256

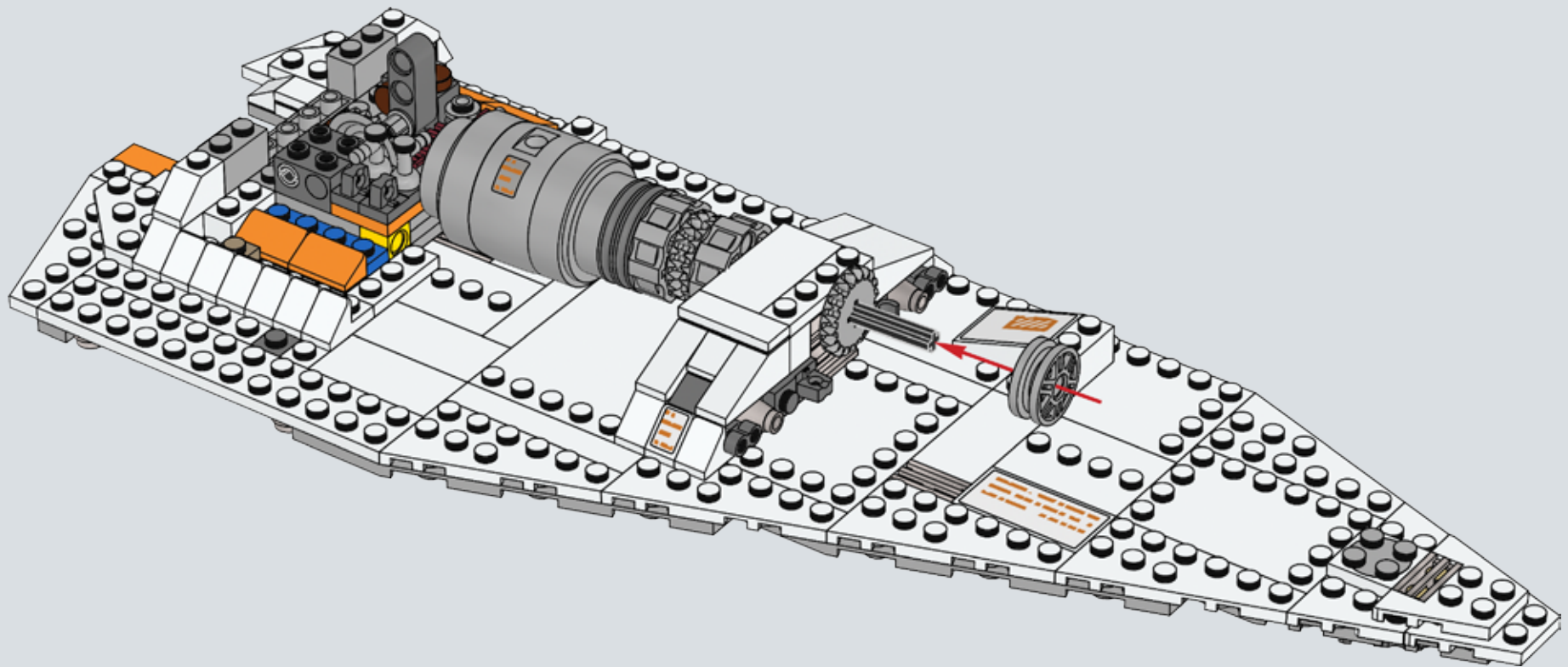



257

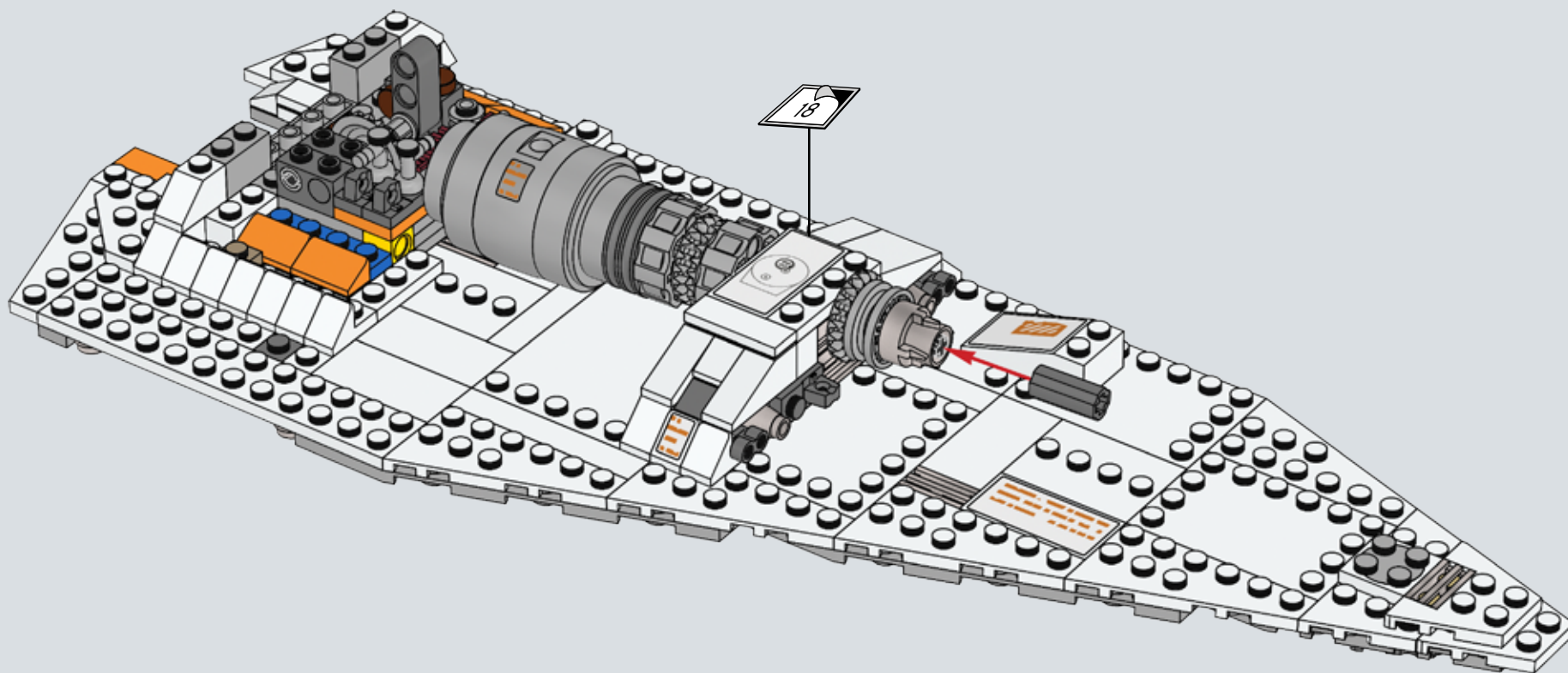

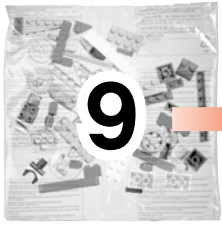

2x

1x

258

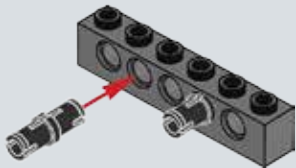

1x

259

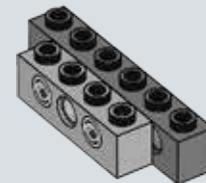

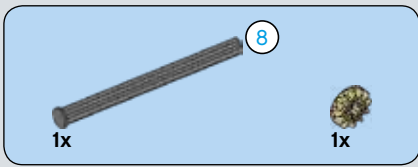

260

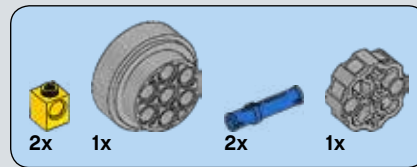
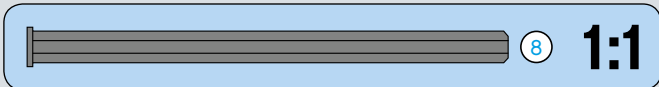
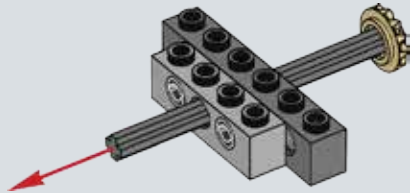
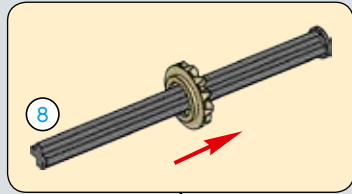

261

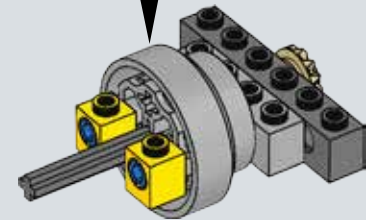
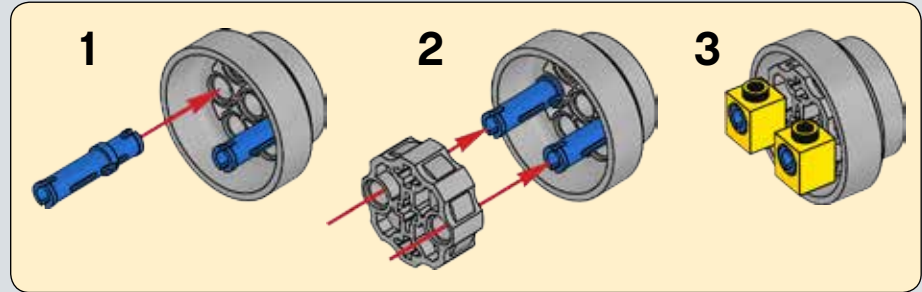

262

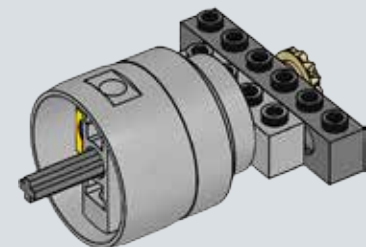

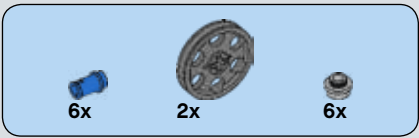

263

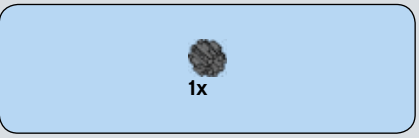
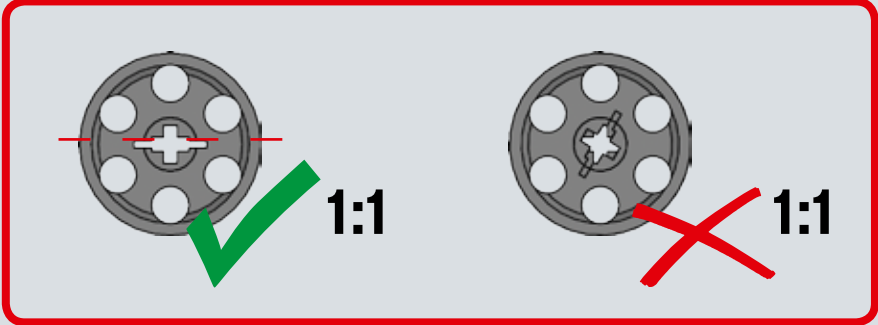
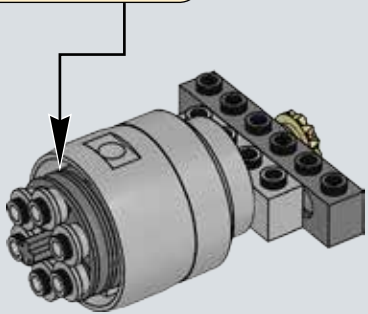
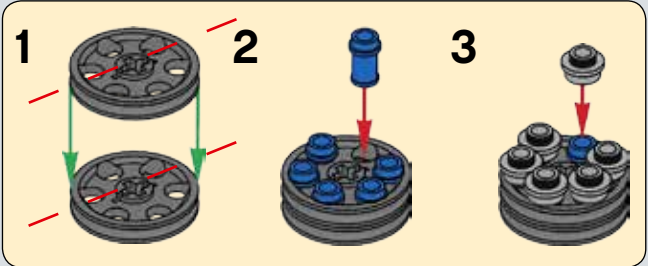

264

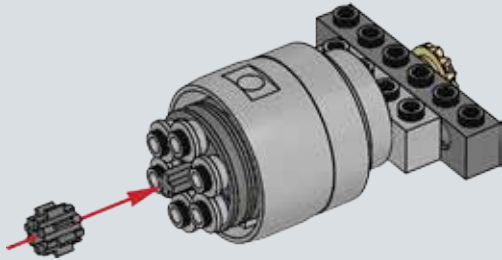

265

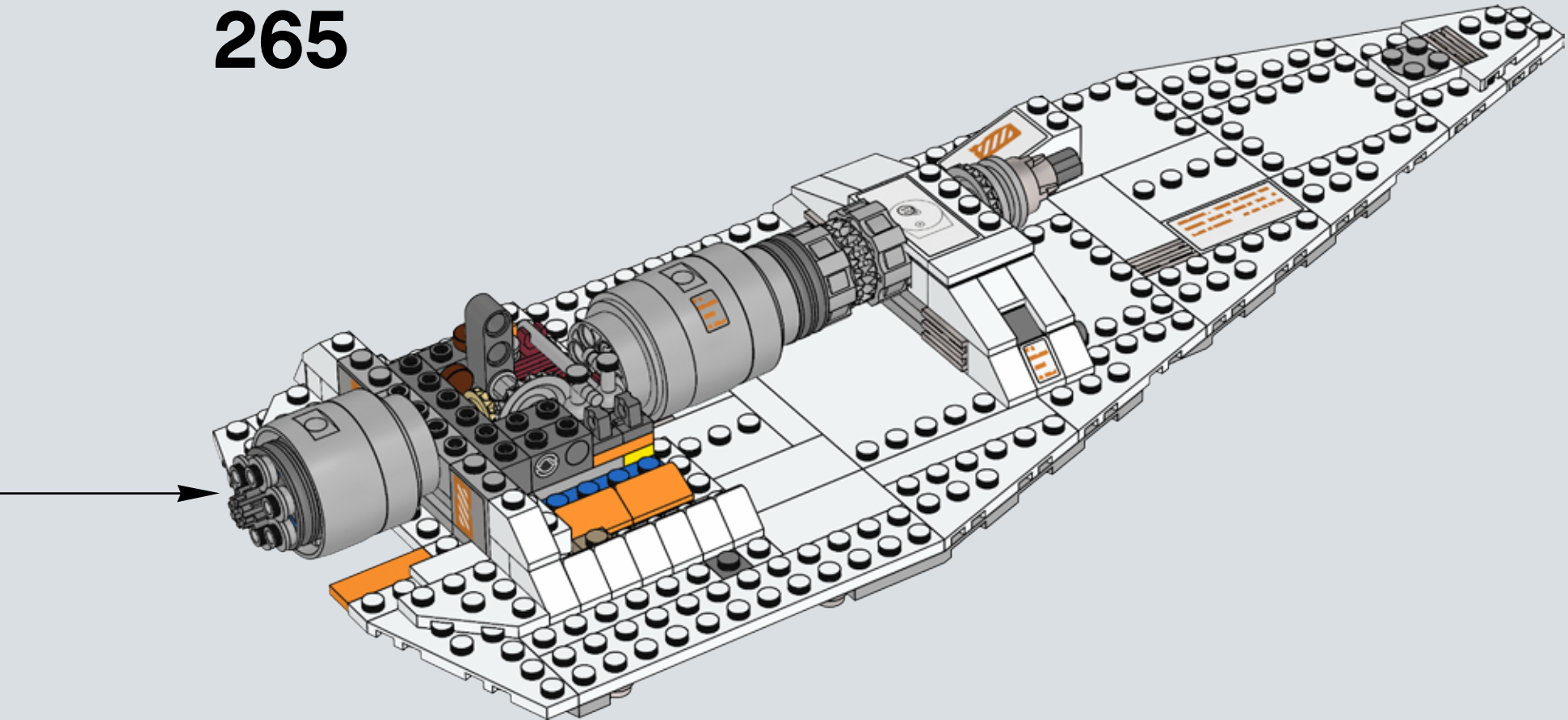



266

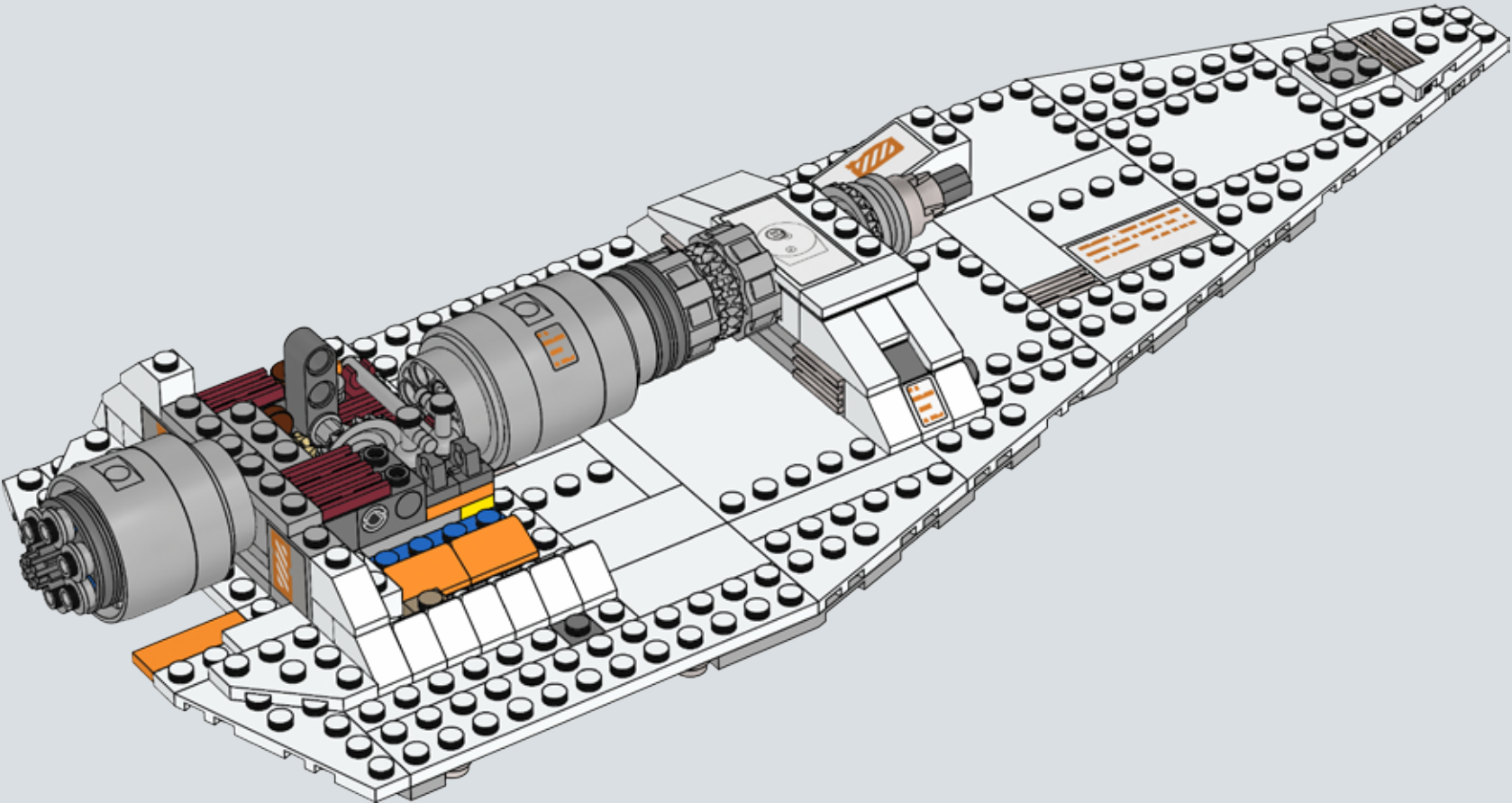



267

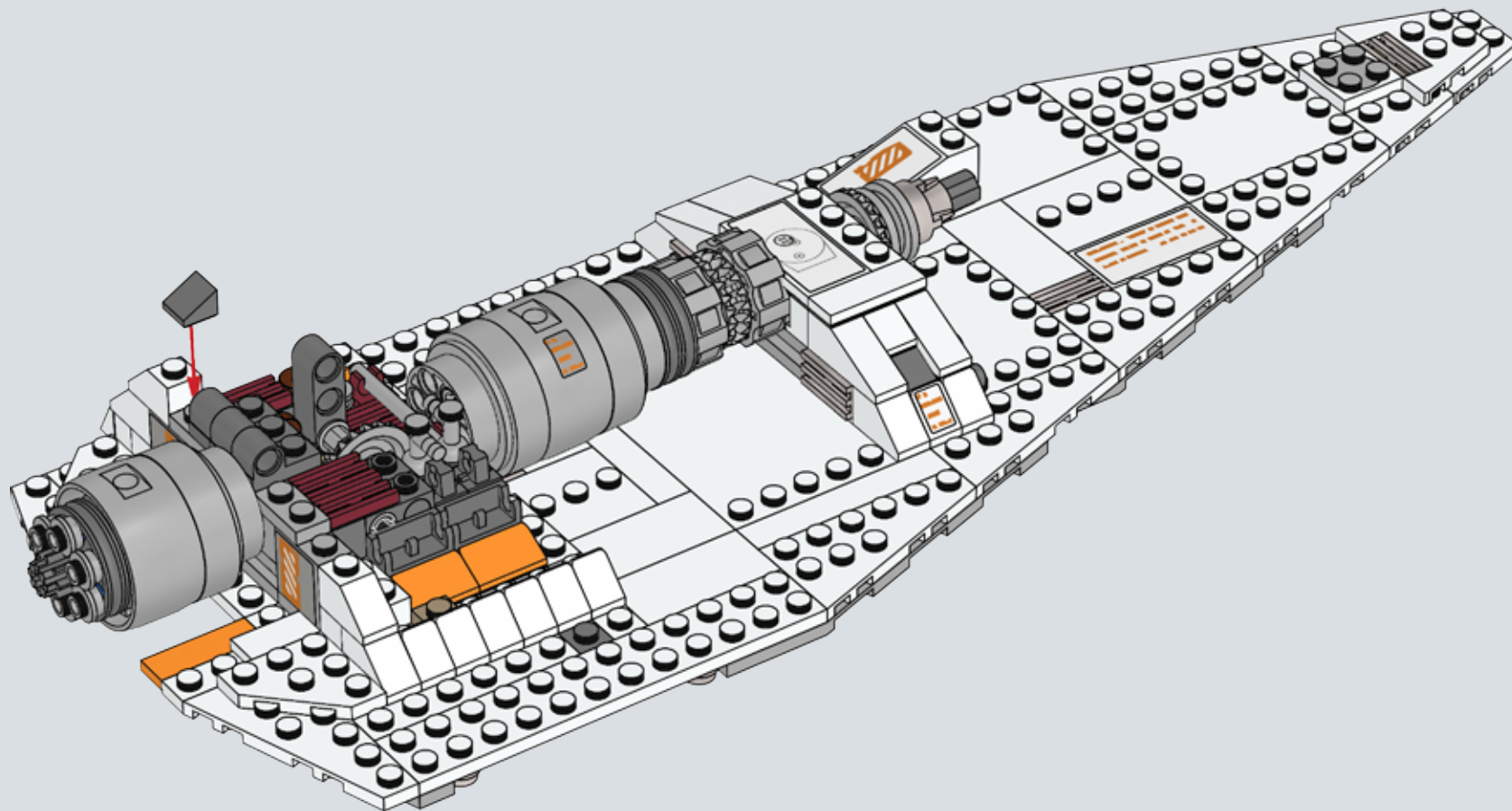

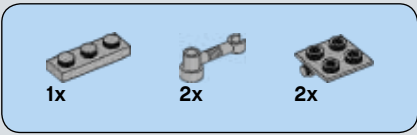

268

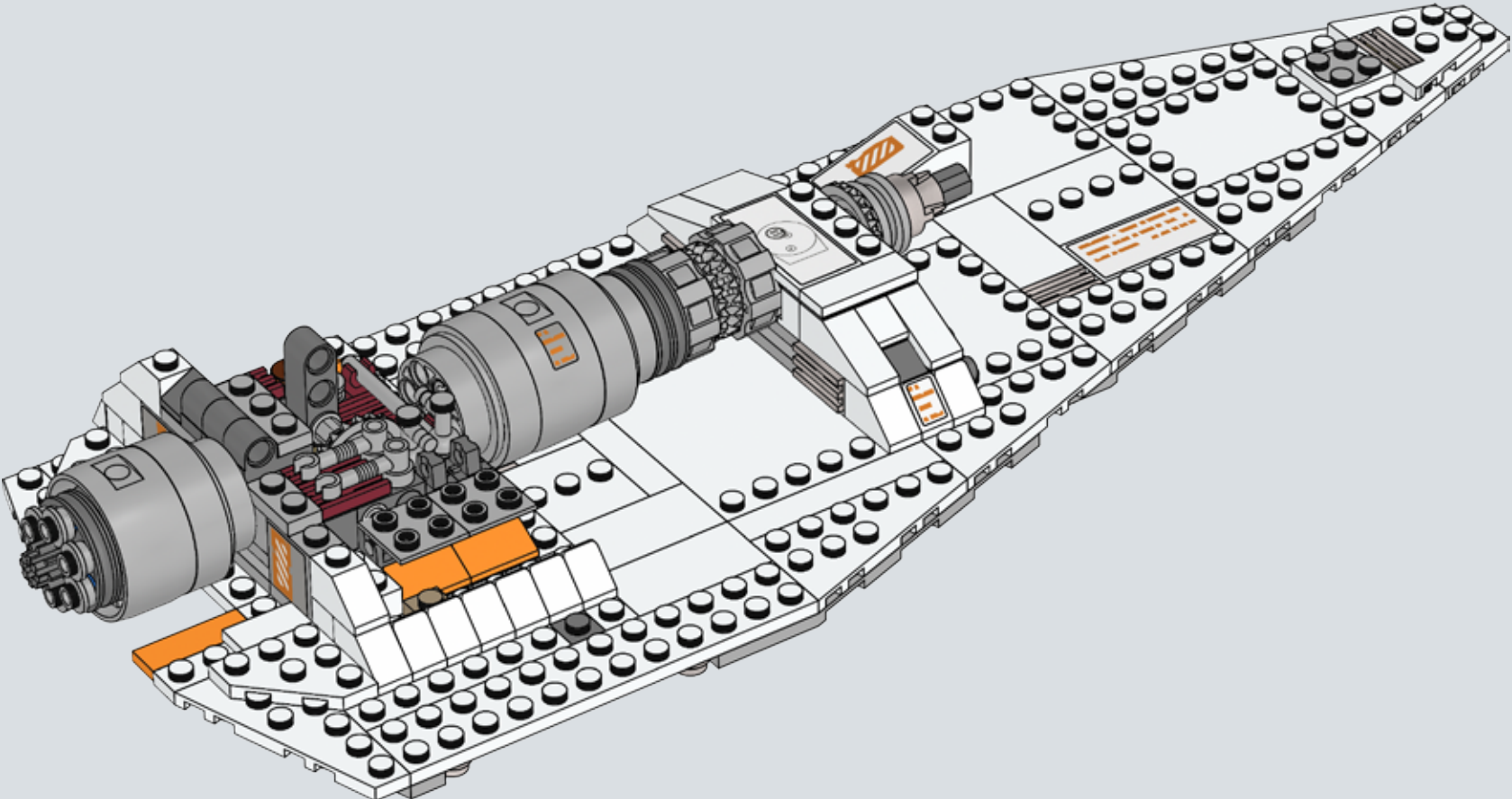



269

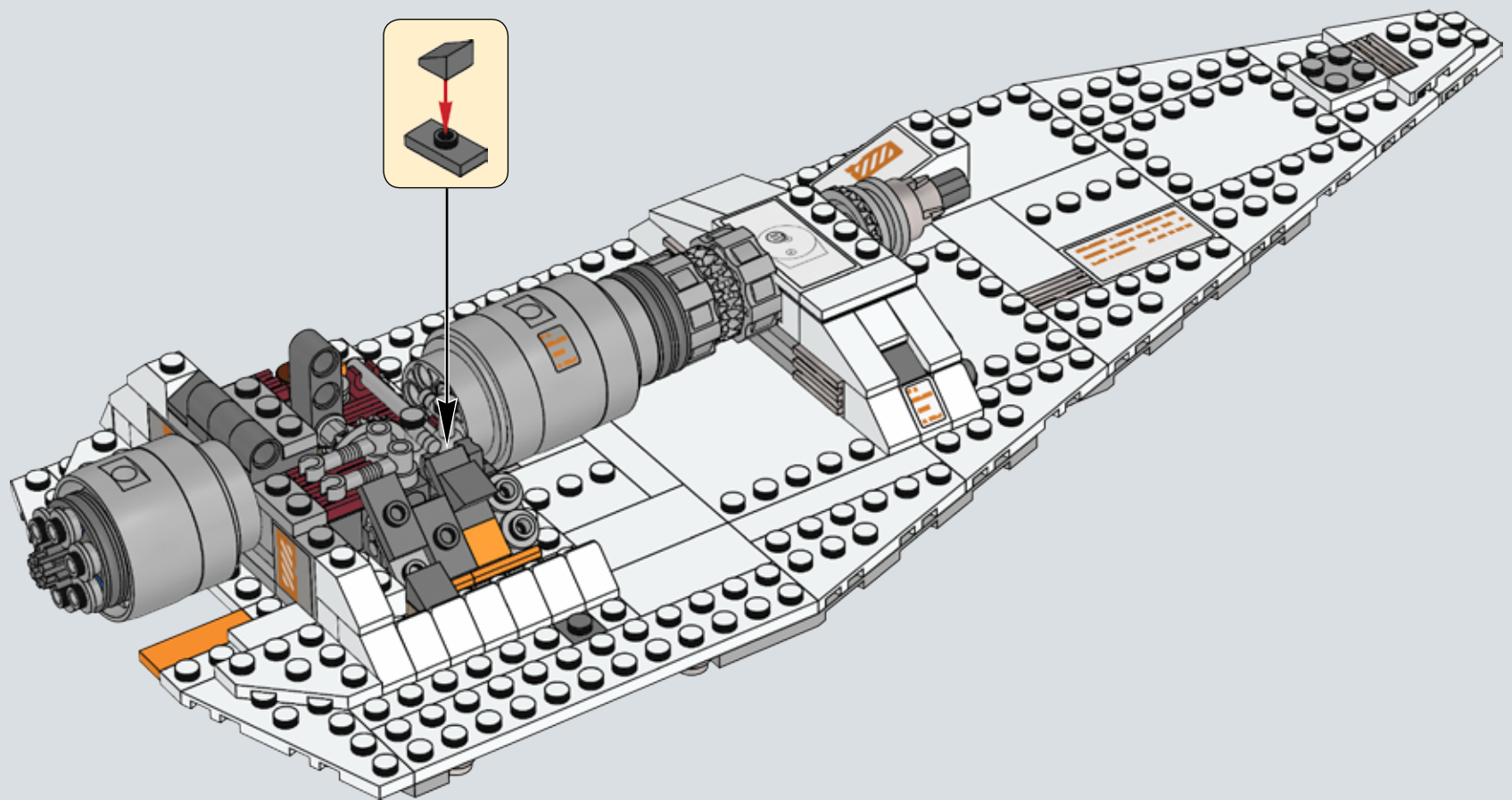



270

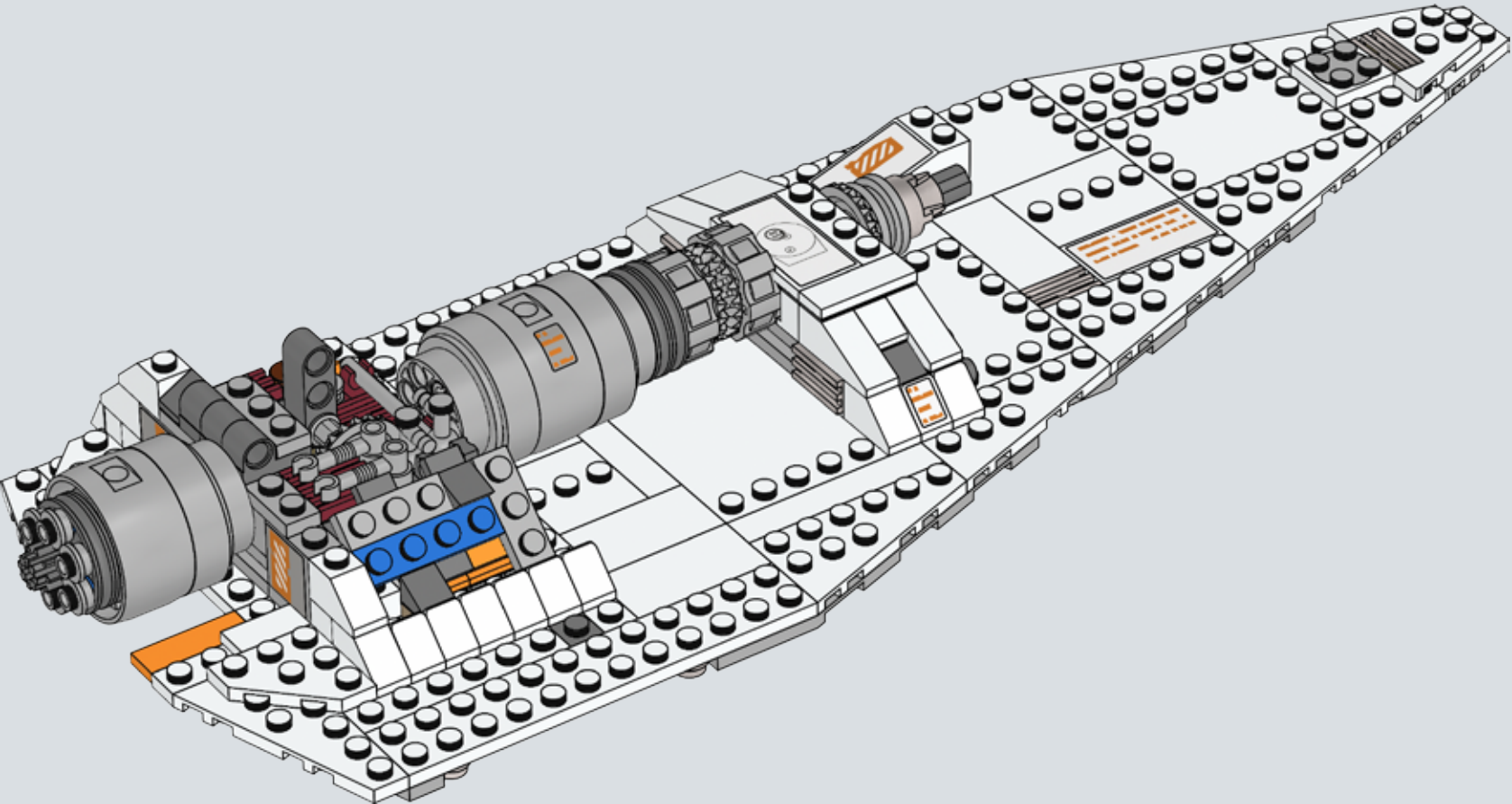

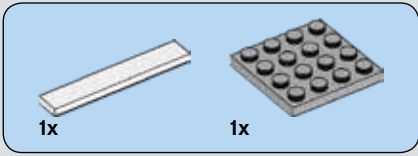
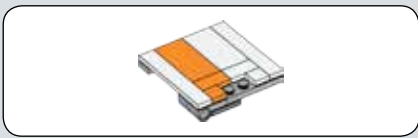

271

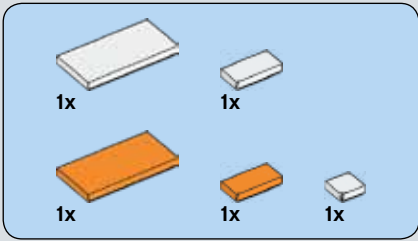
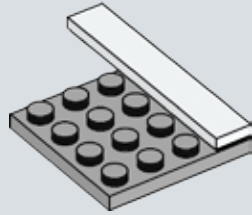

272

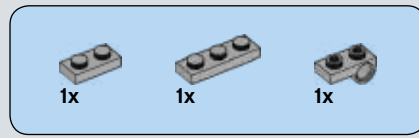
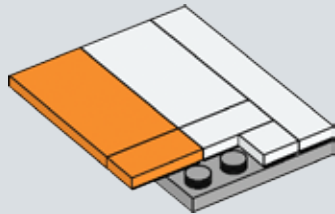

273

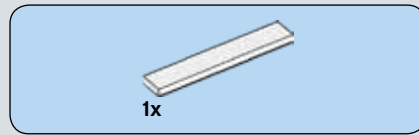
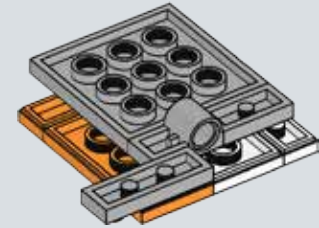
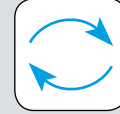

274

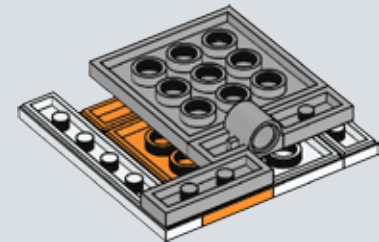



2x

275

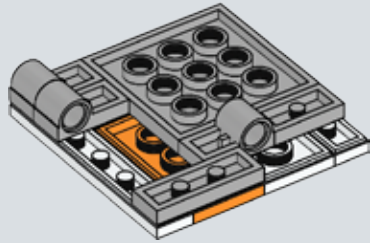

1x



1x

276

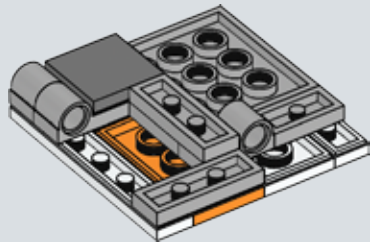

1x

277

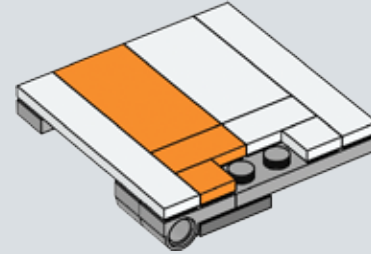
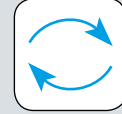

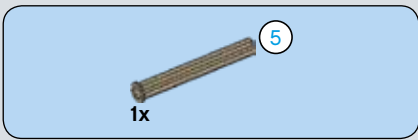

278

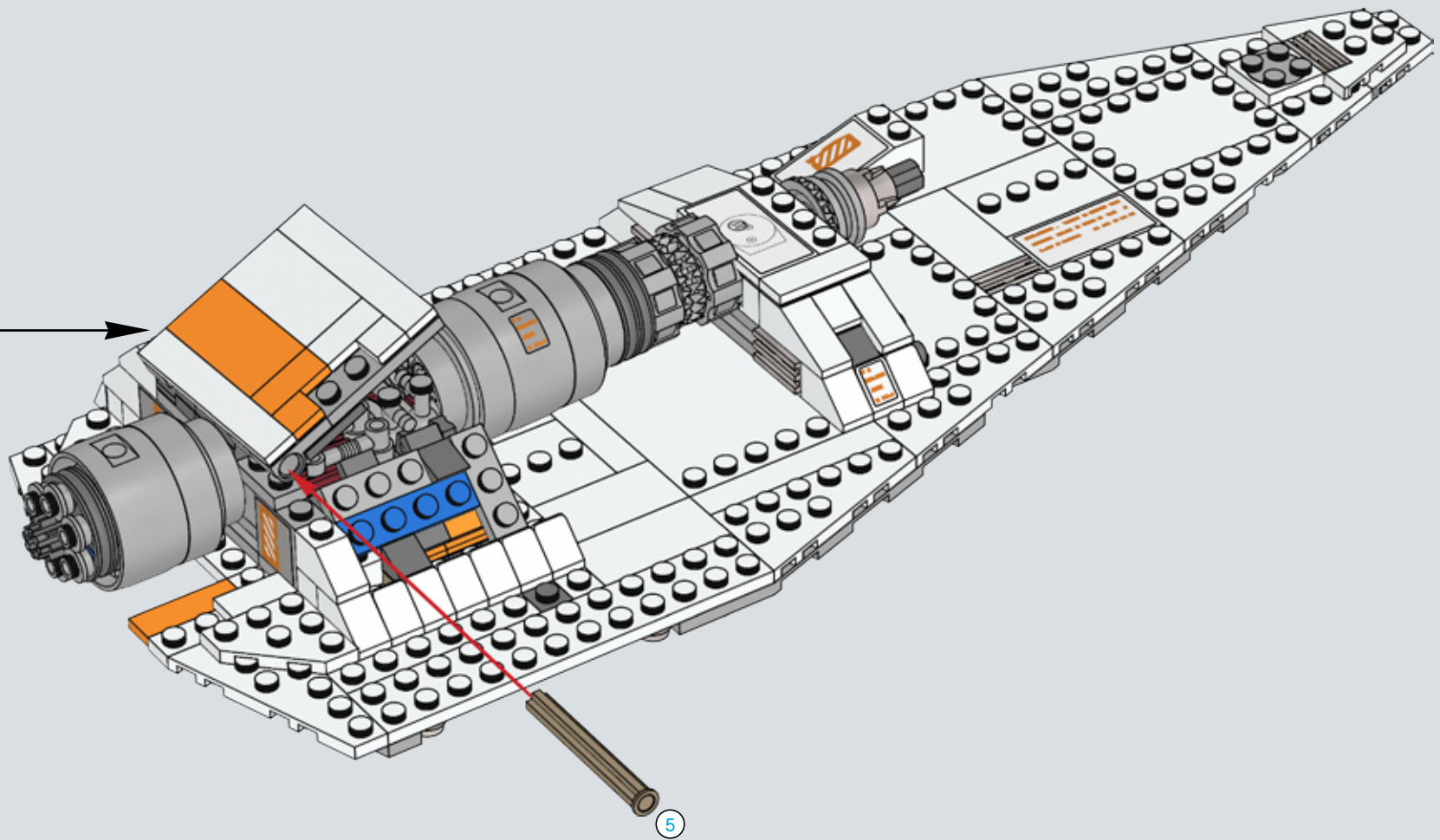



1x

279

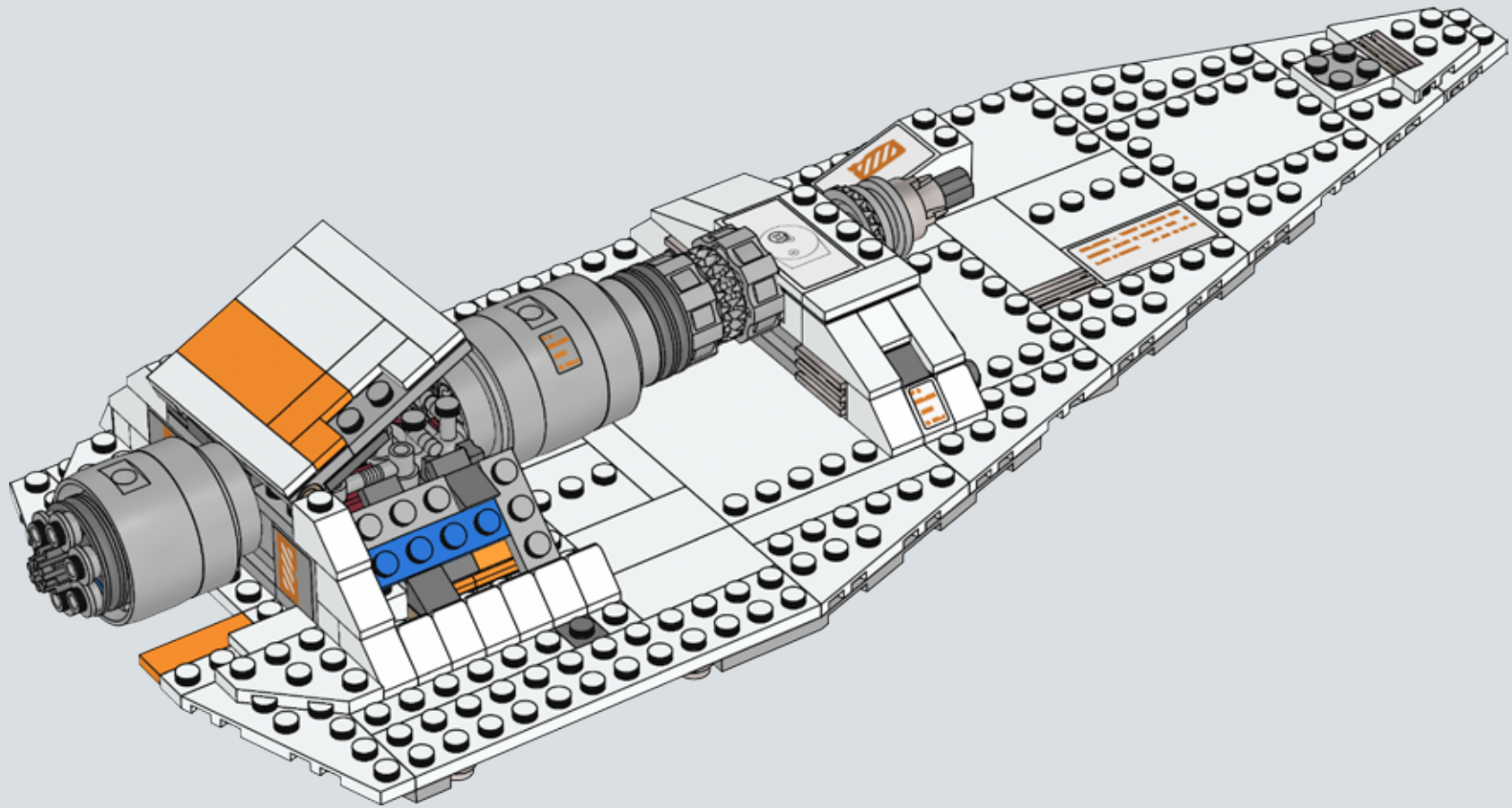

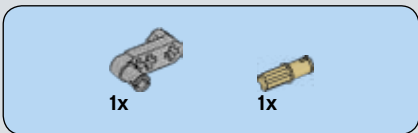

280

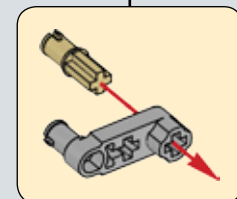
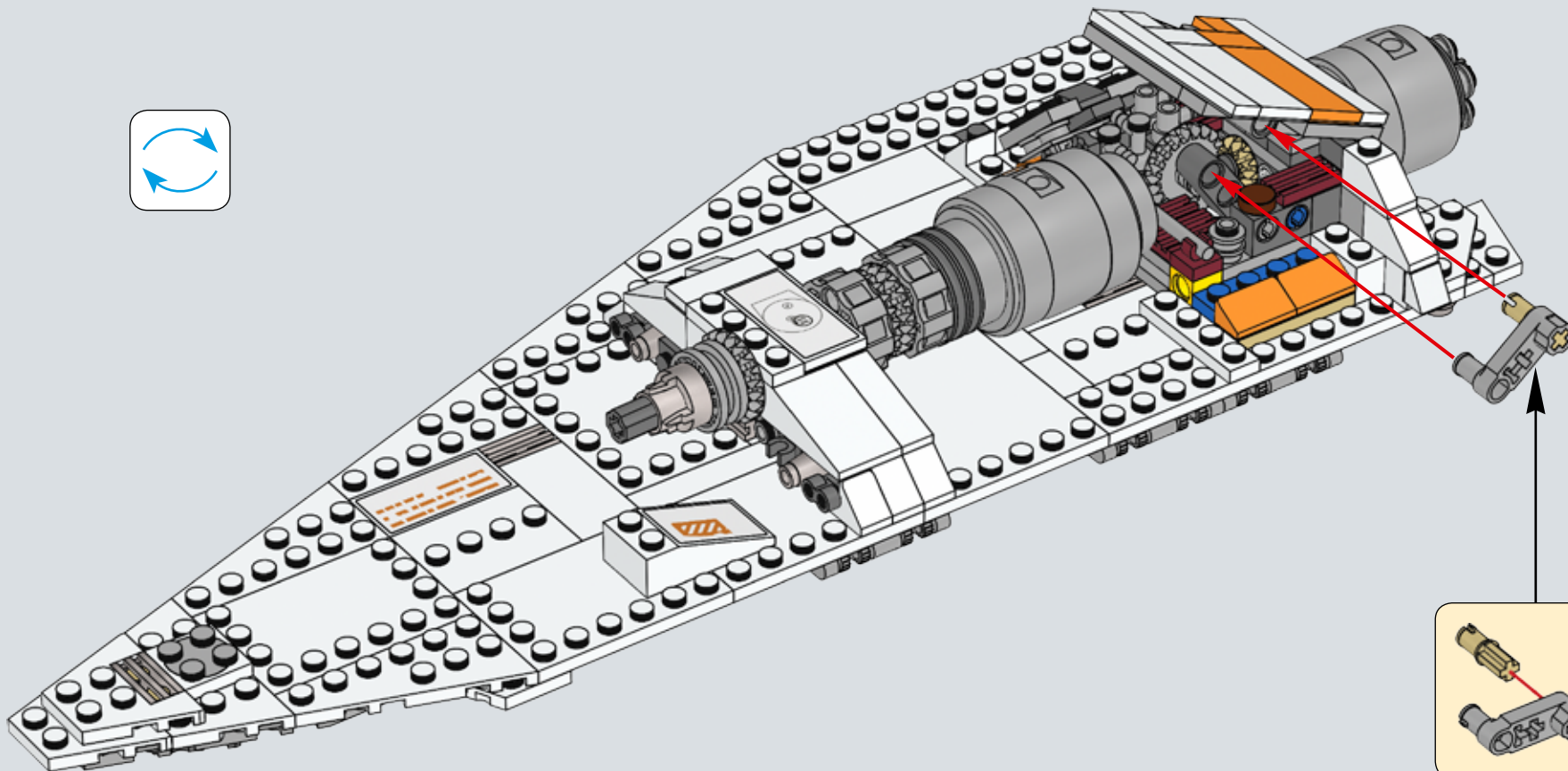
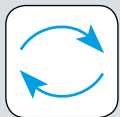

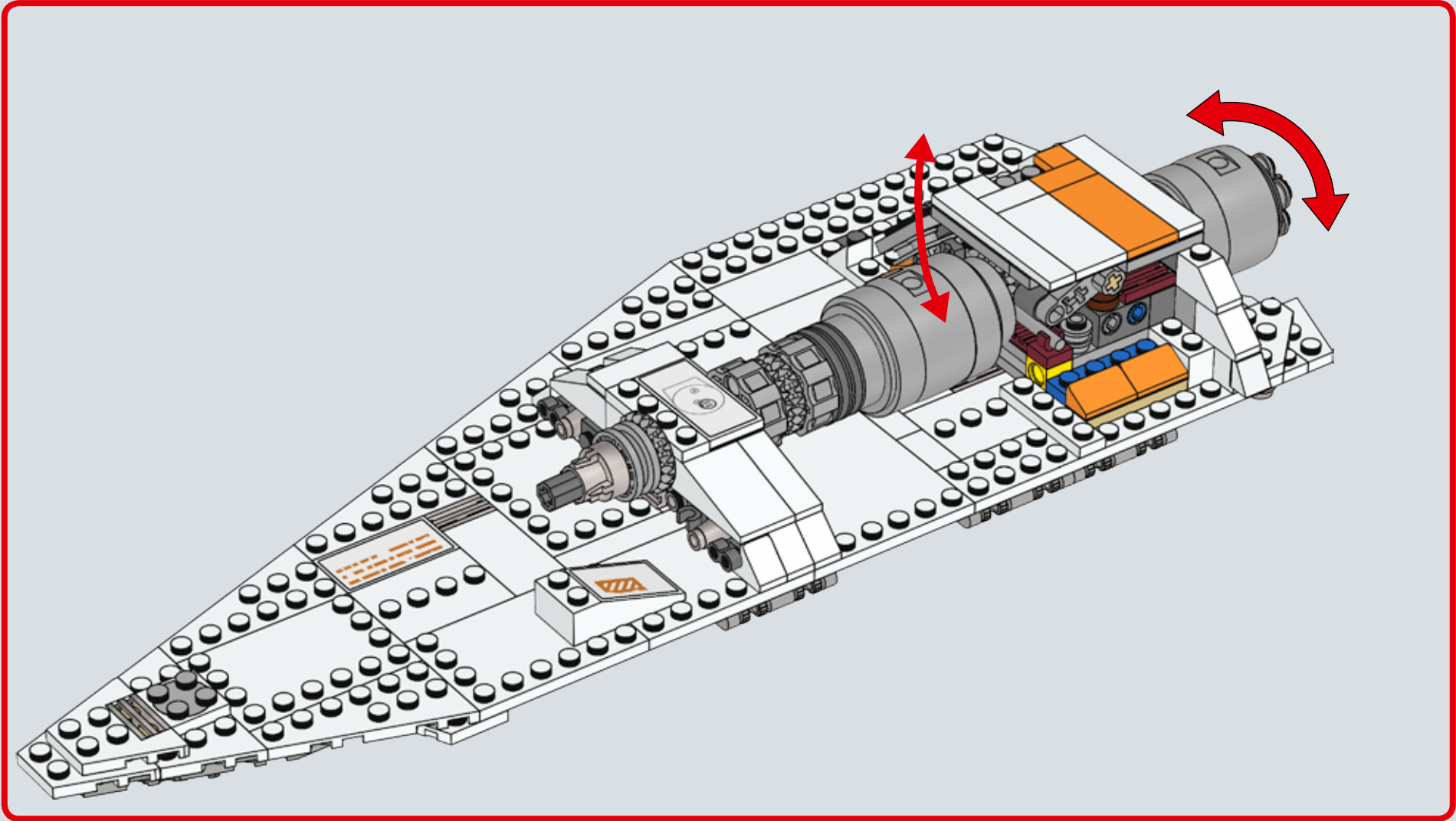



281

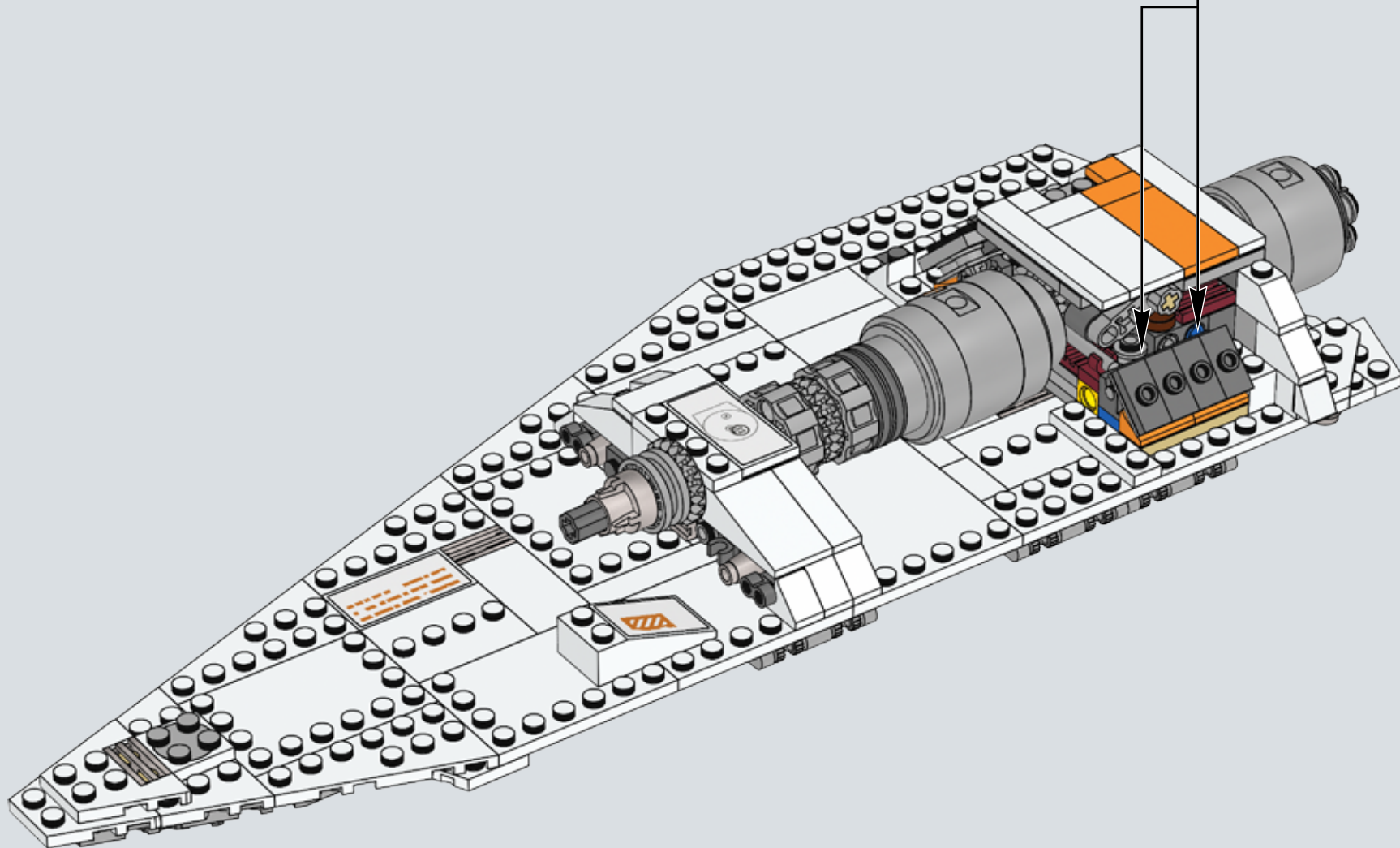
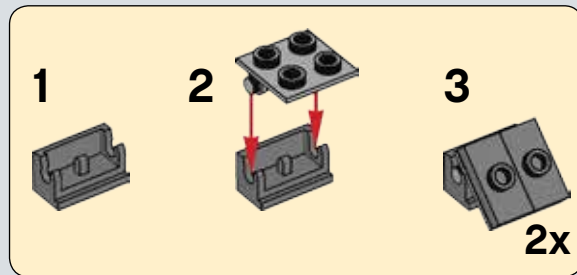

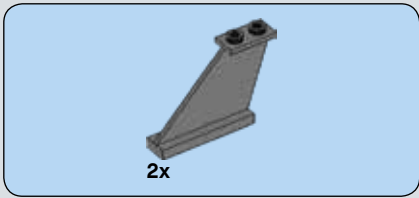

282

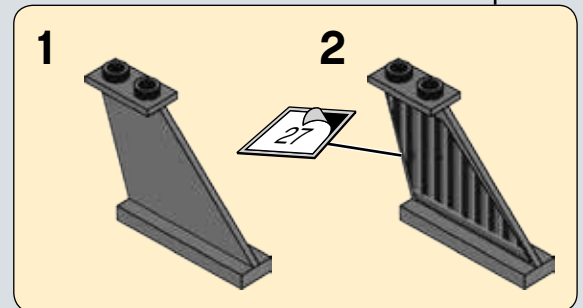
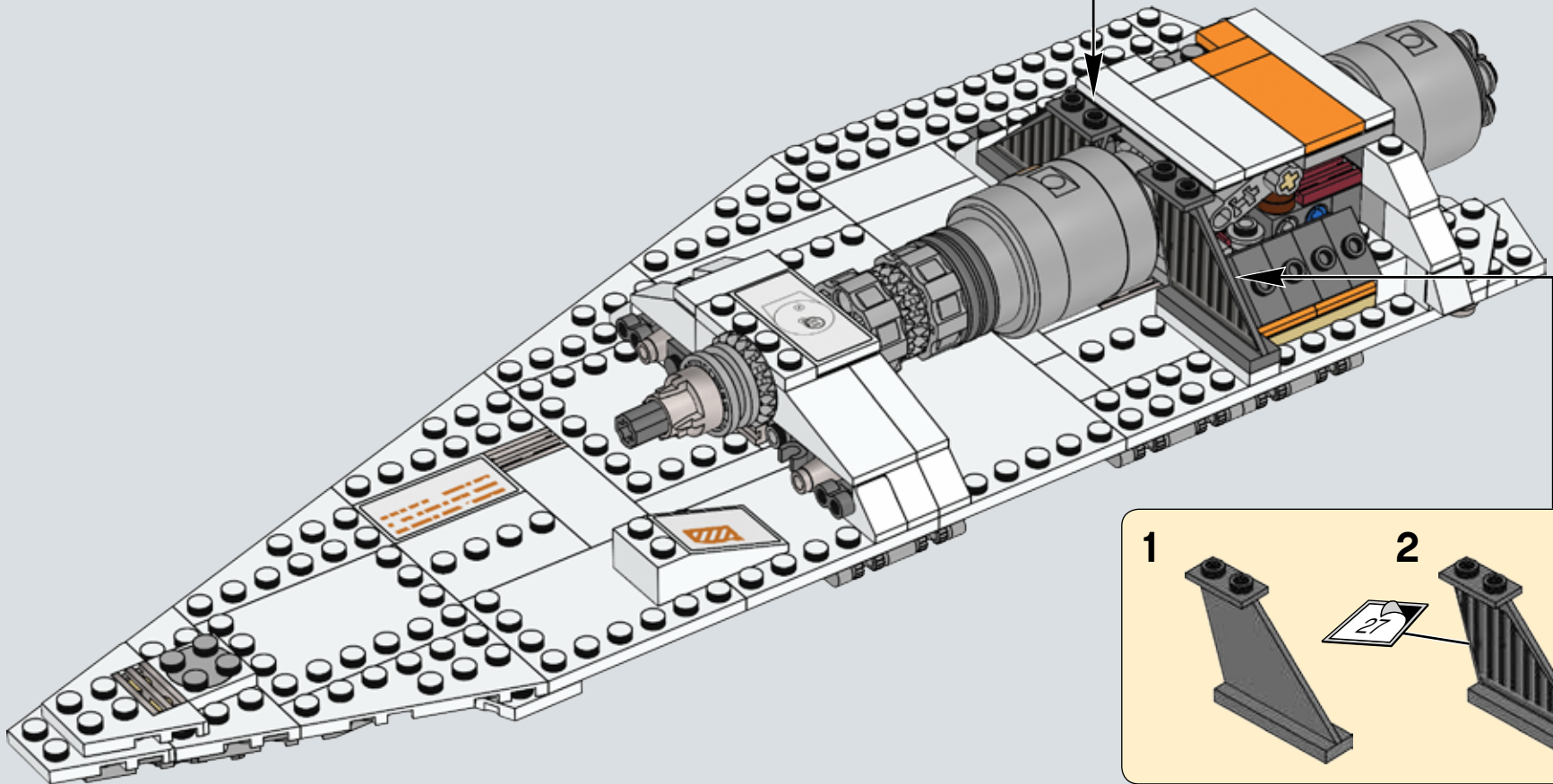
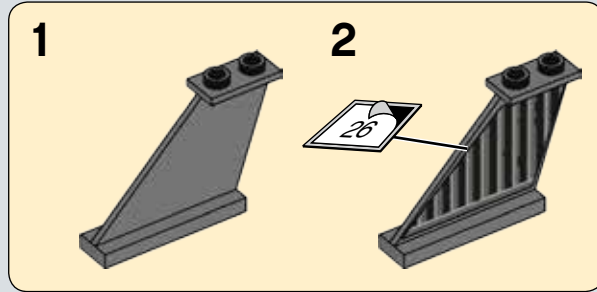



283

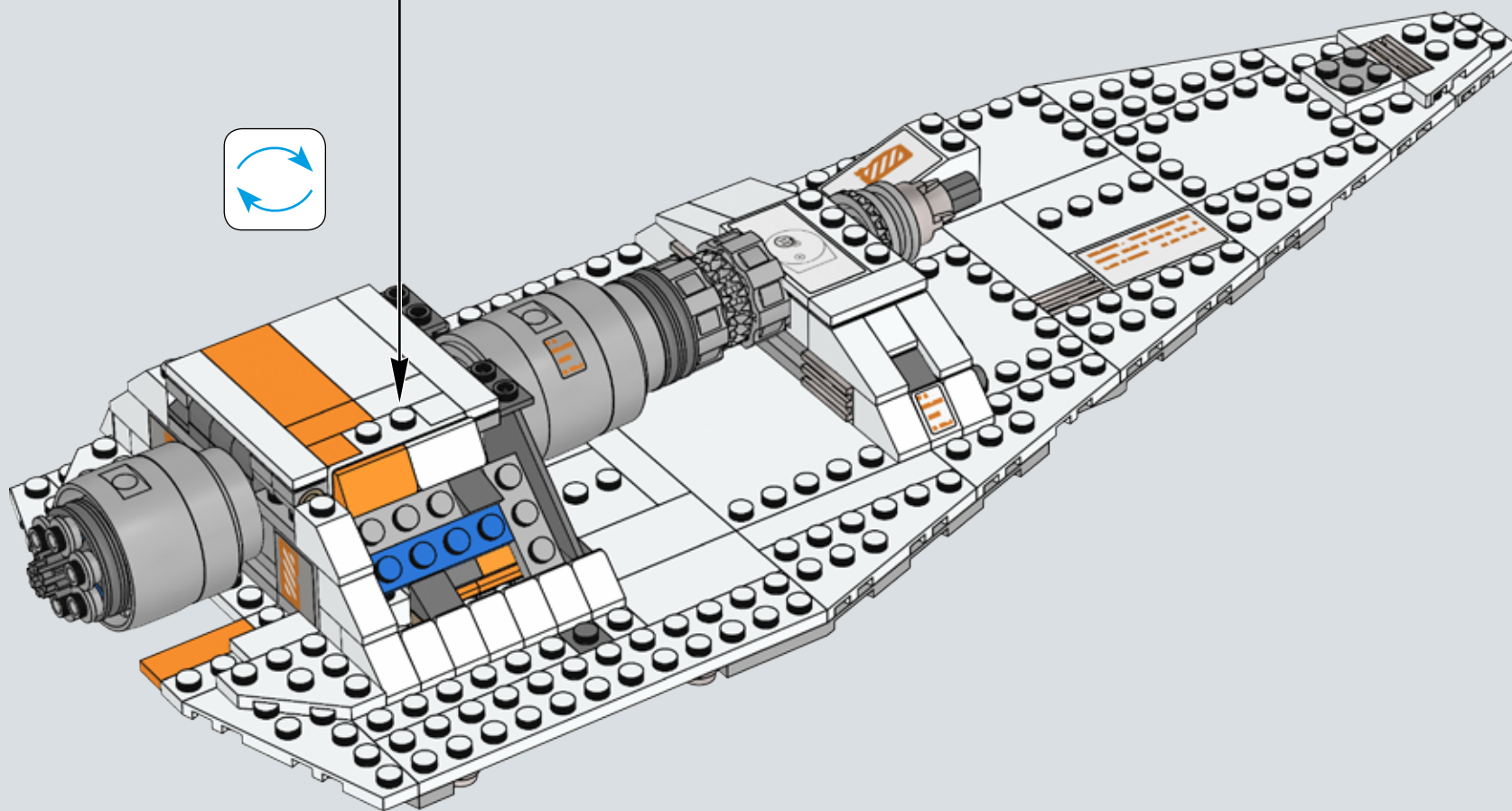
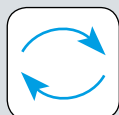
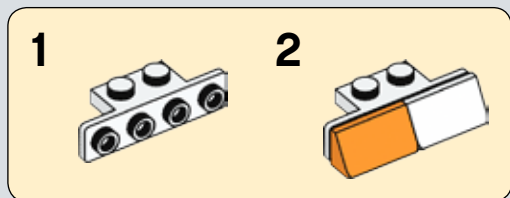

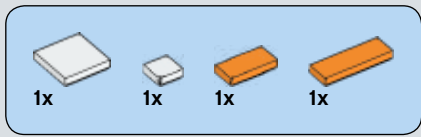

284

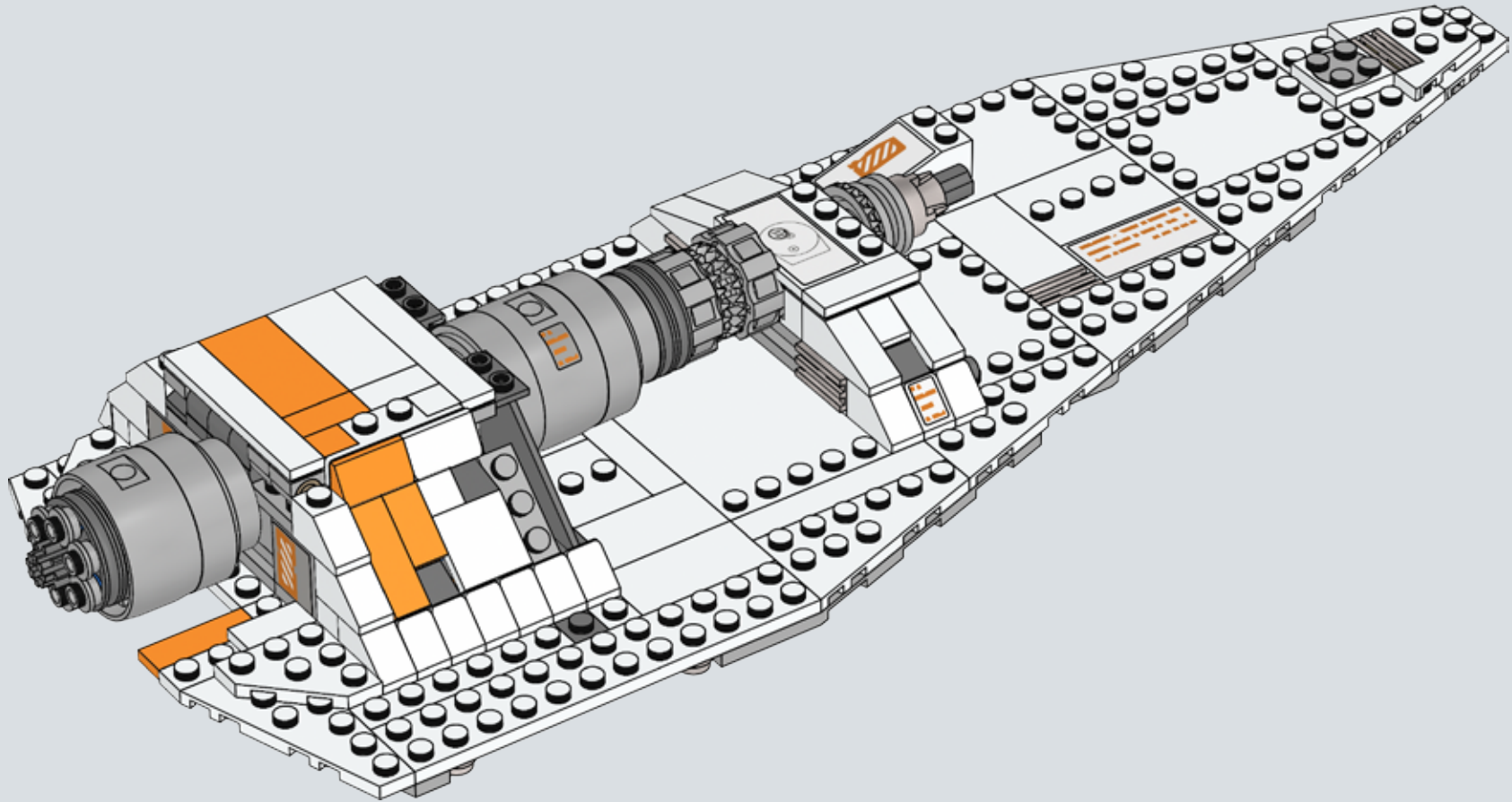

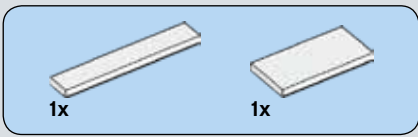

285

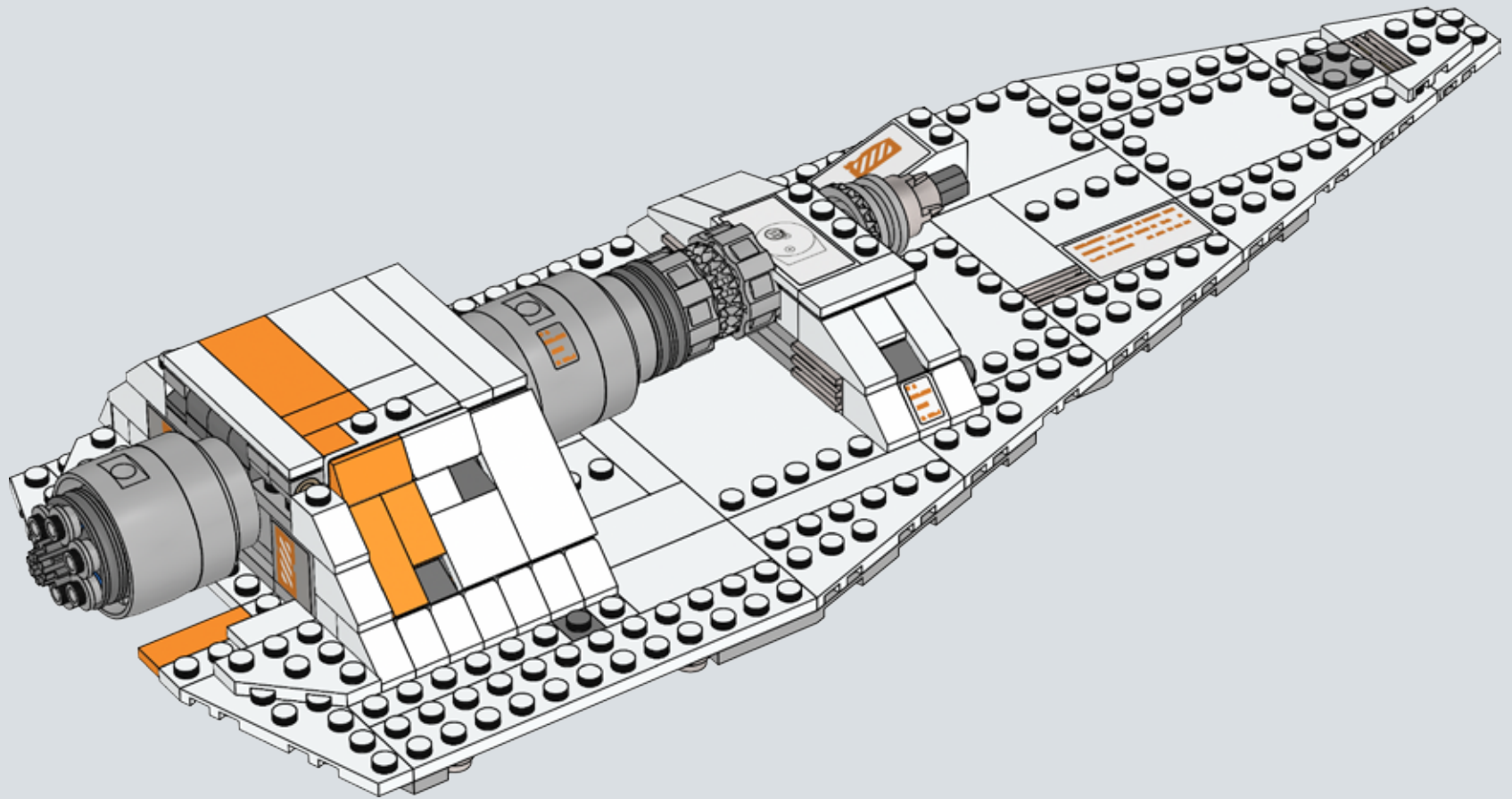



2x



3x

286

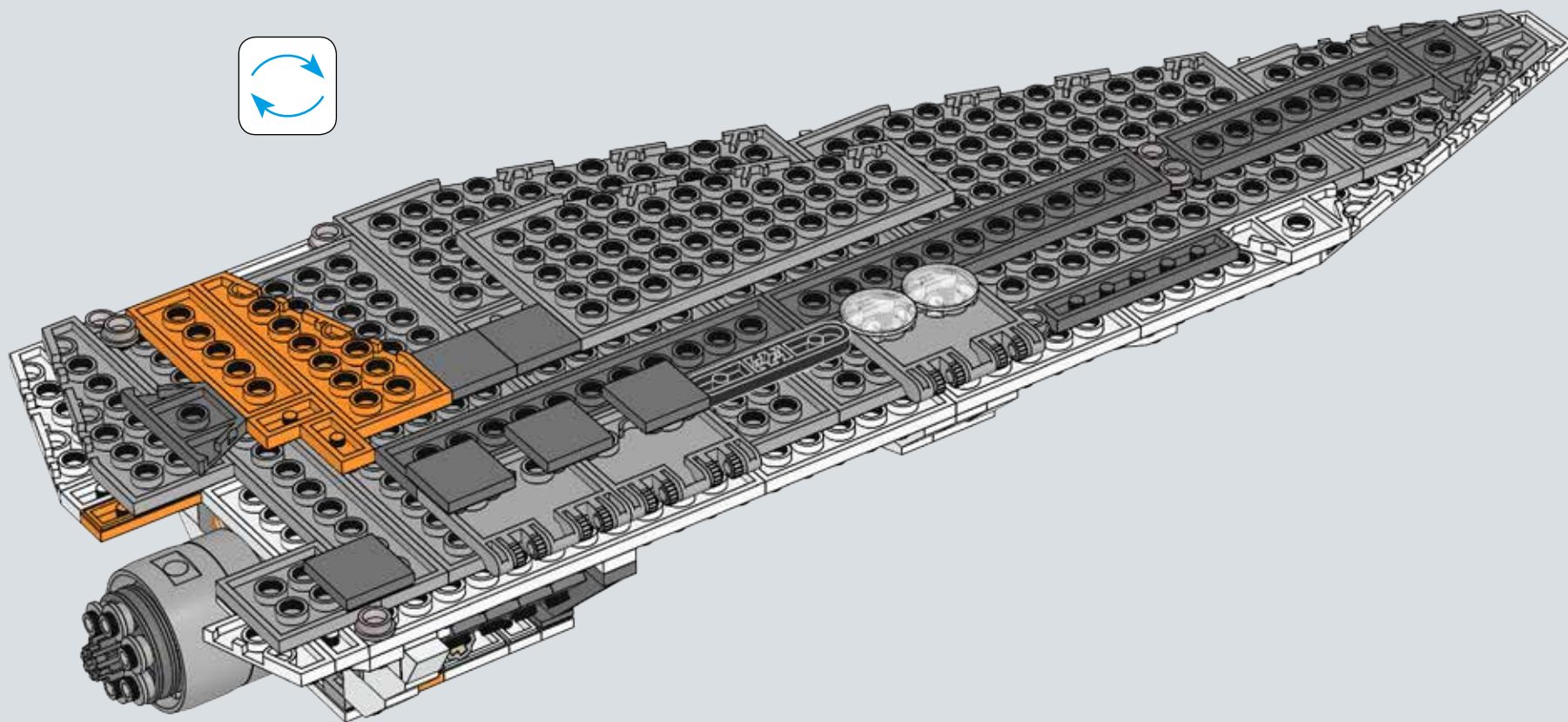
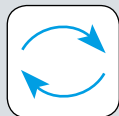

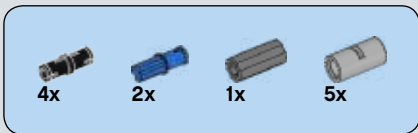

287

1

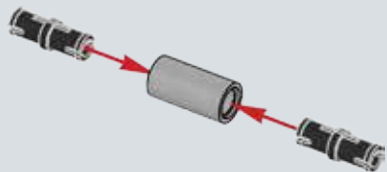

2

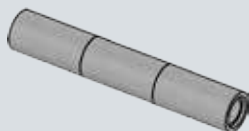

3

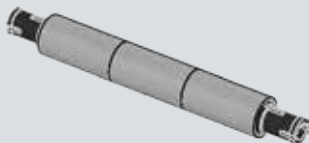

4

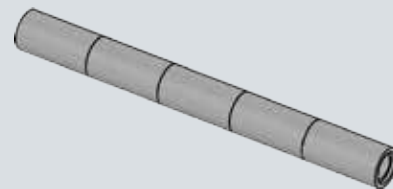

5

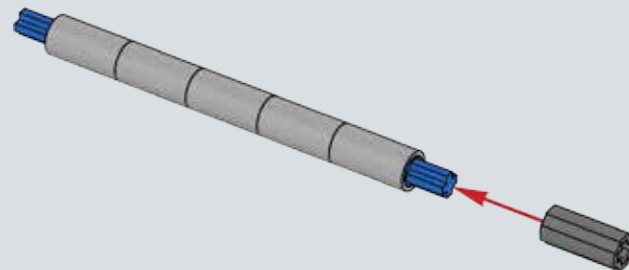

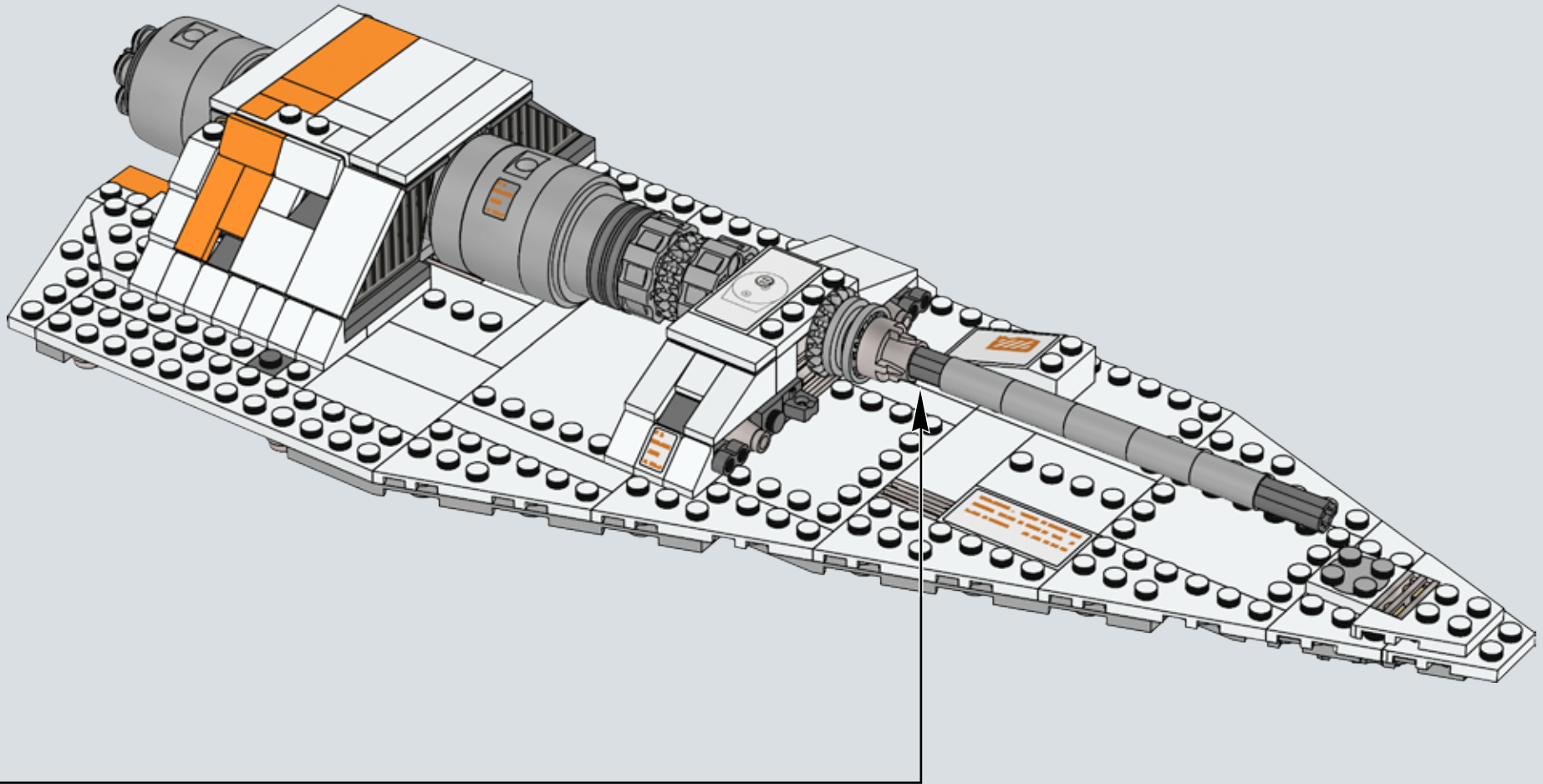

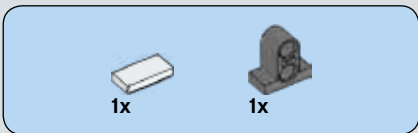

288

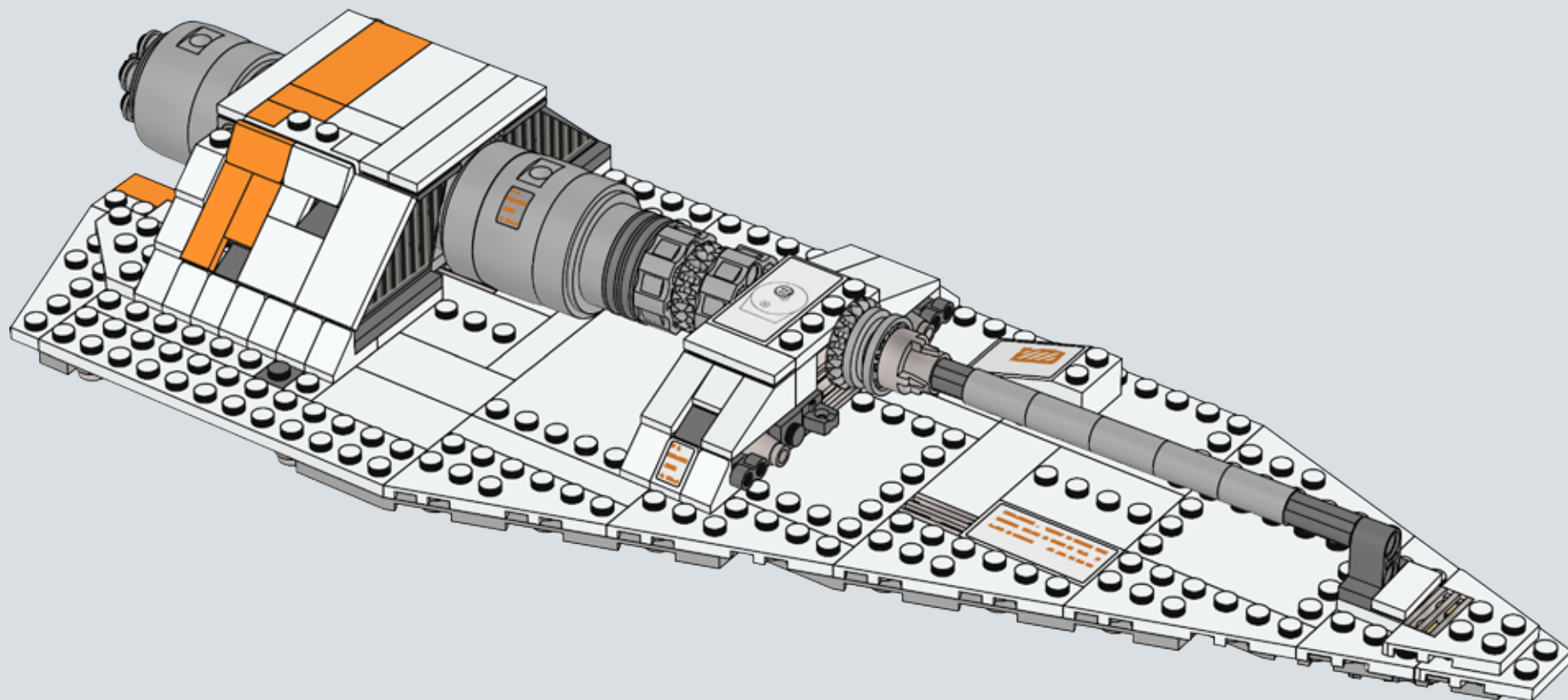

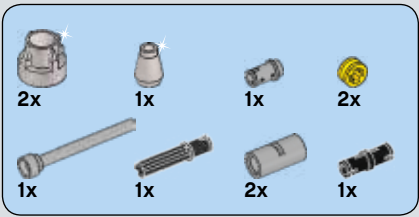

289

1

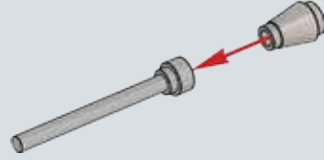

2

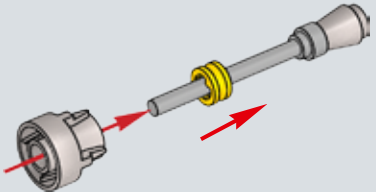

3

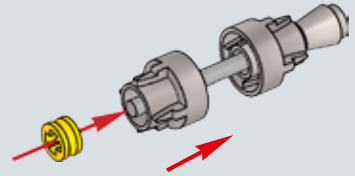

4

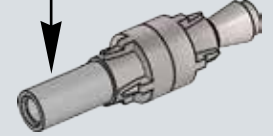
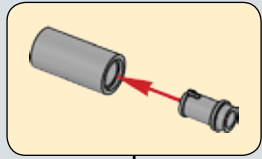

5

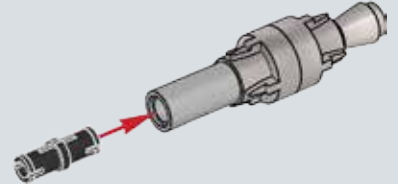

6

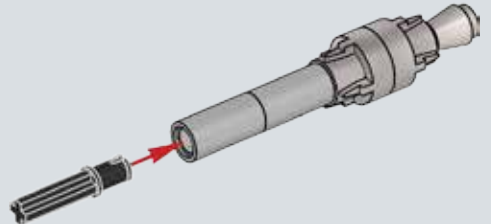

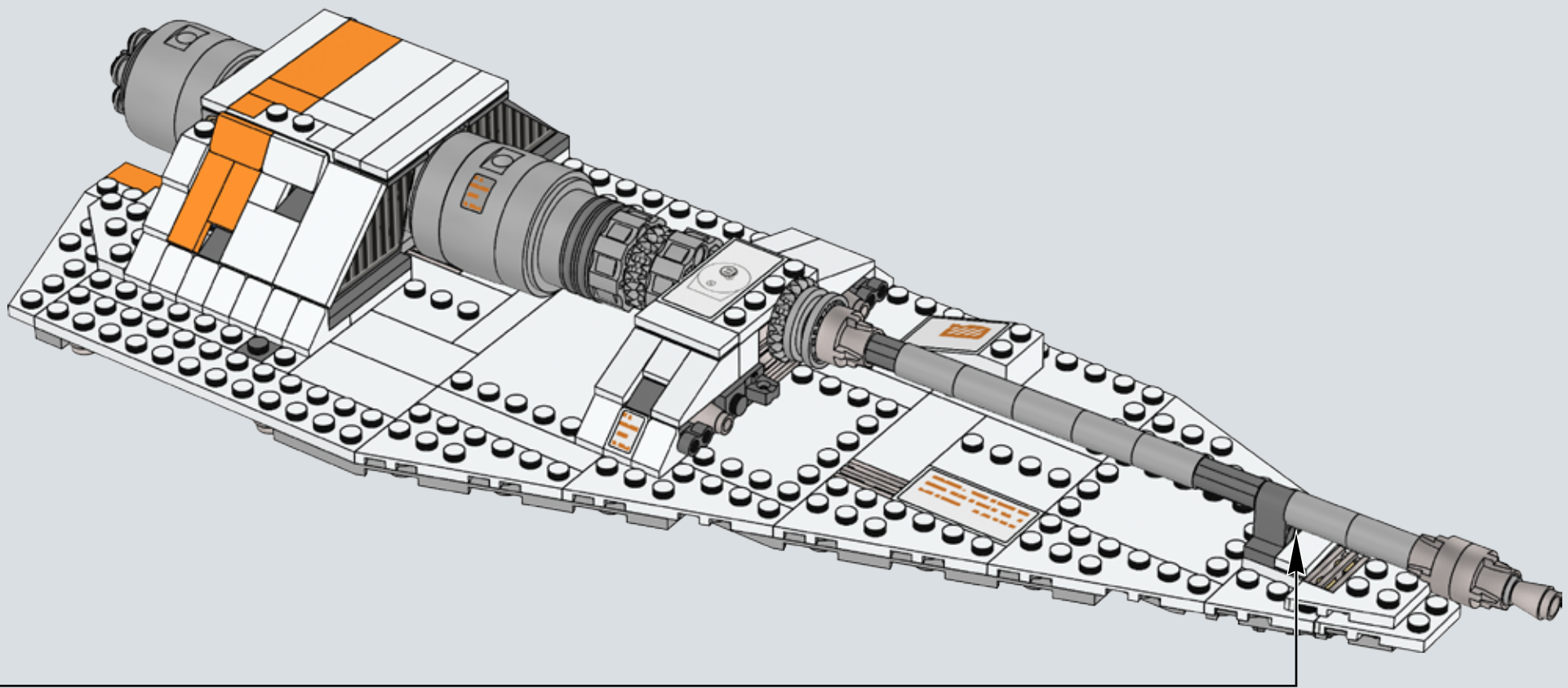

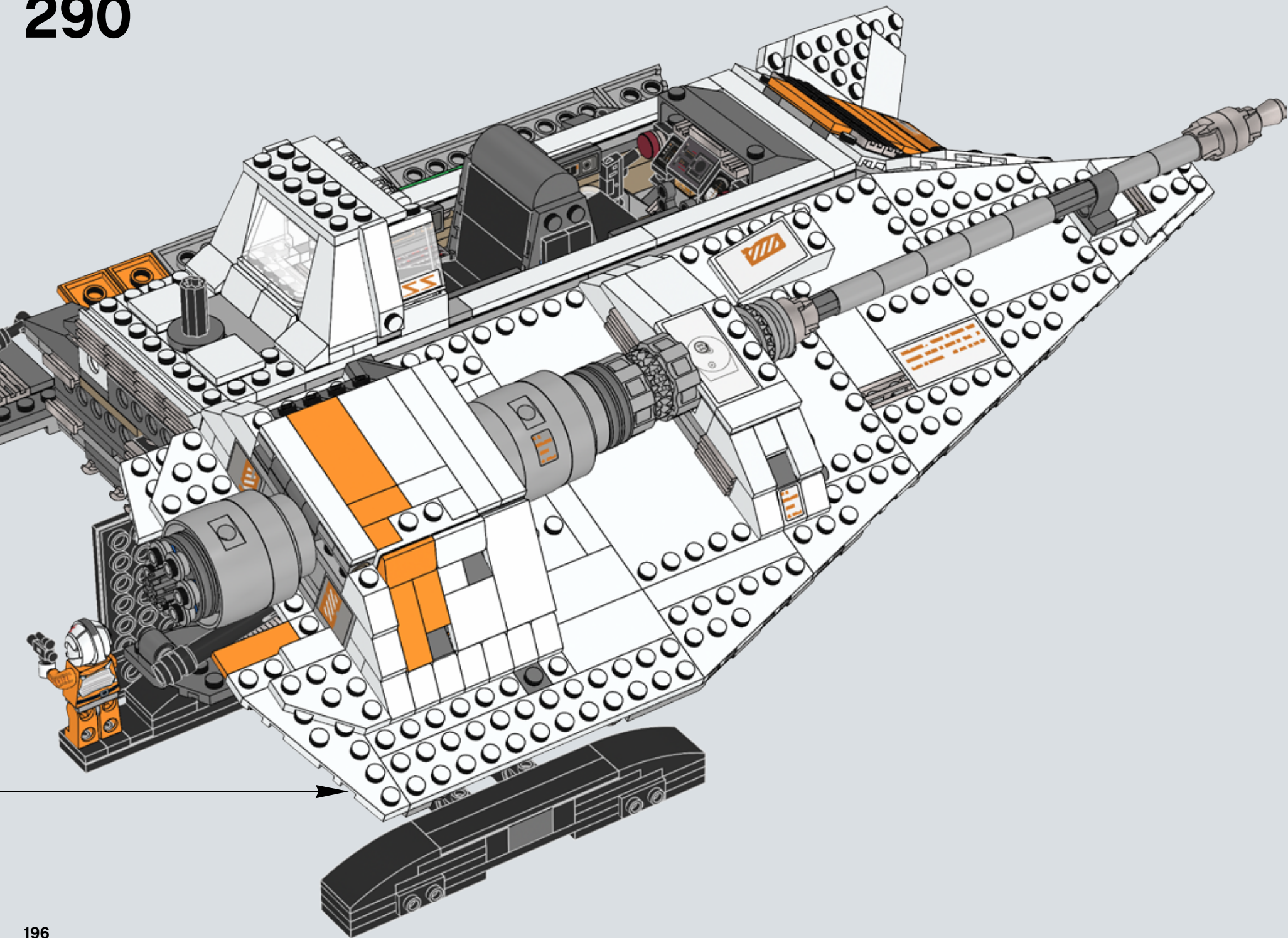

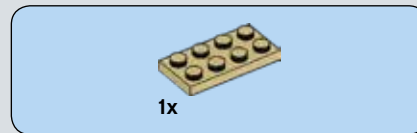
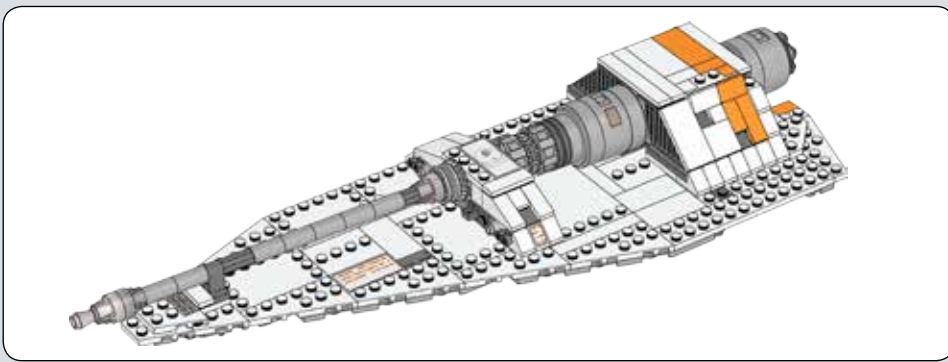

292

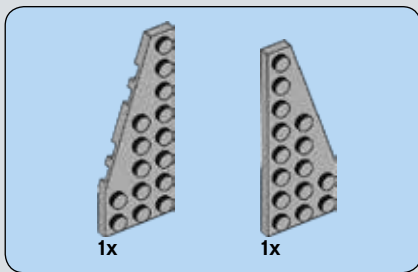
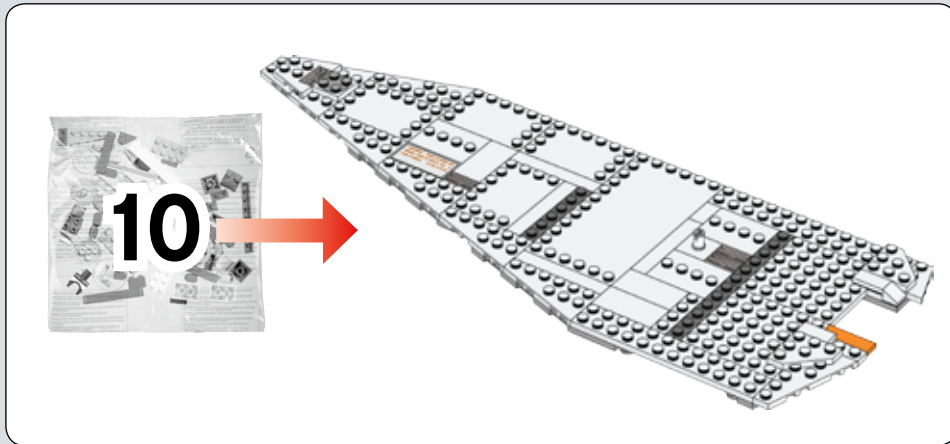

291

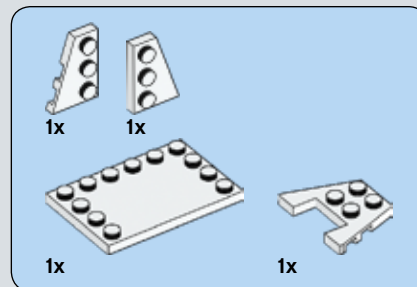
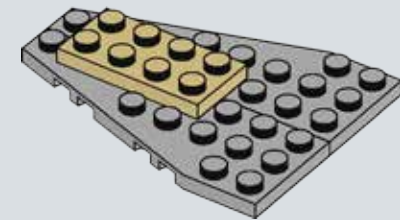
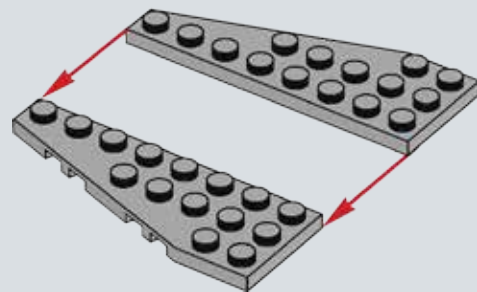

293

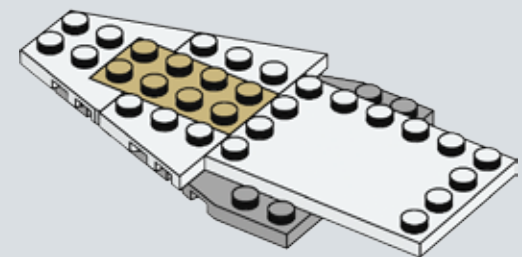

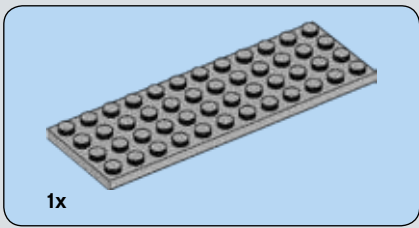

294

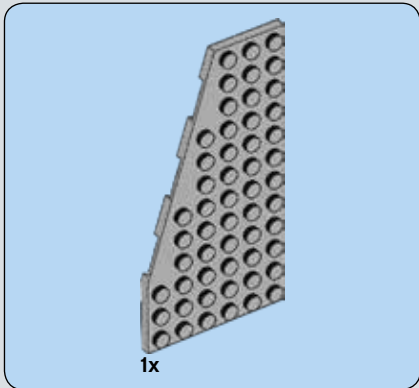
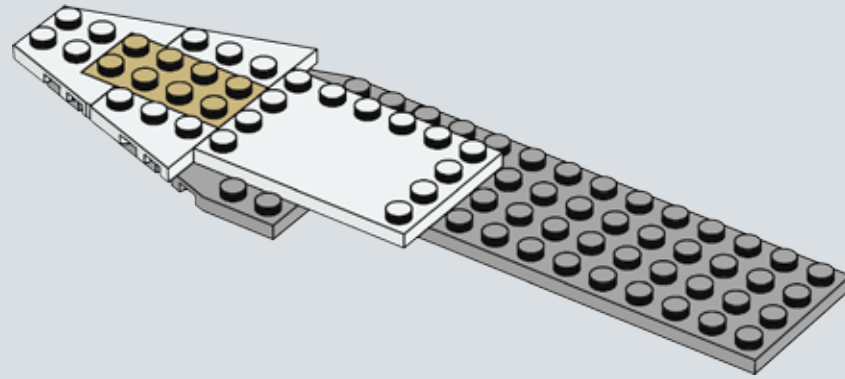

295

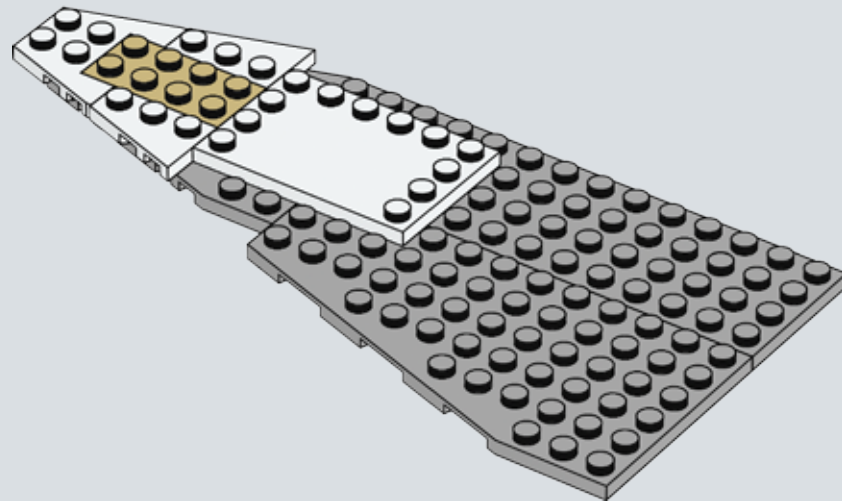

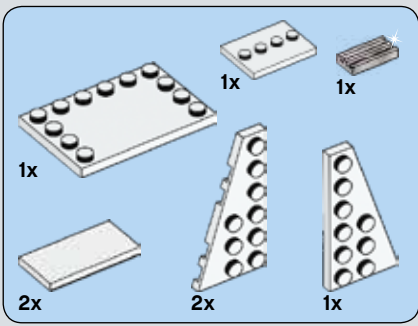

296

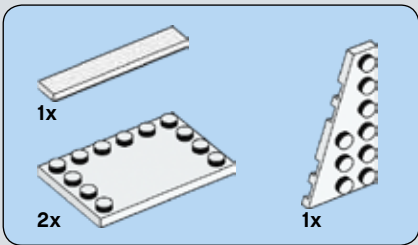
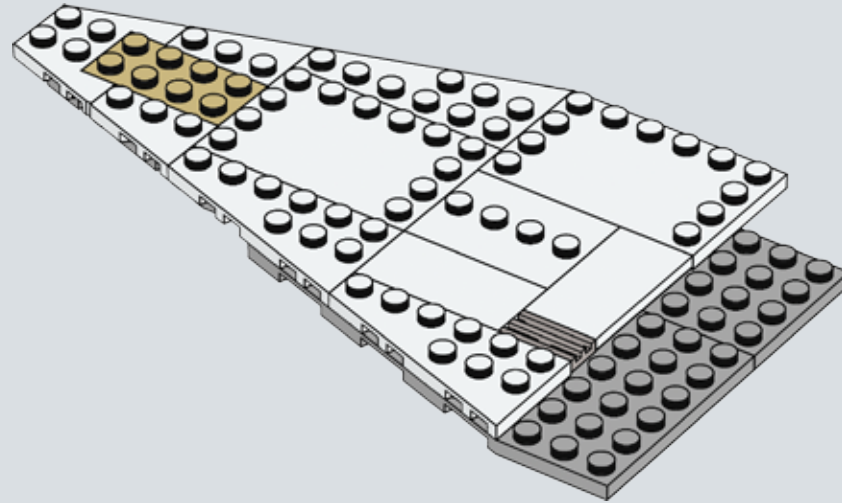

297

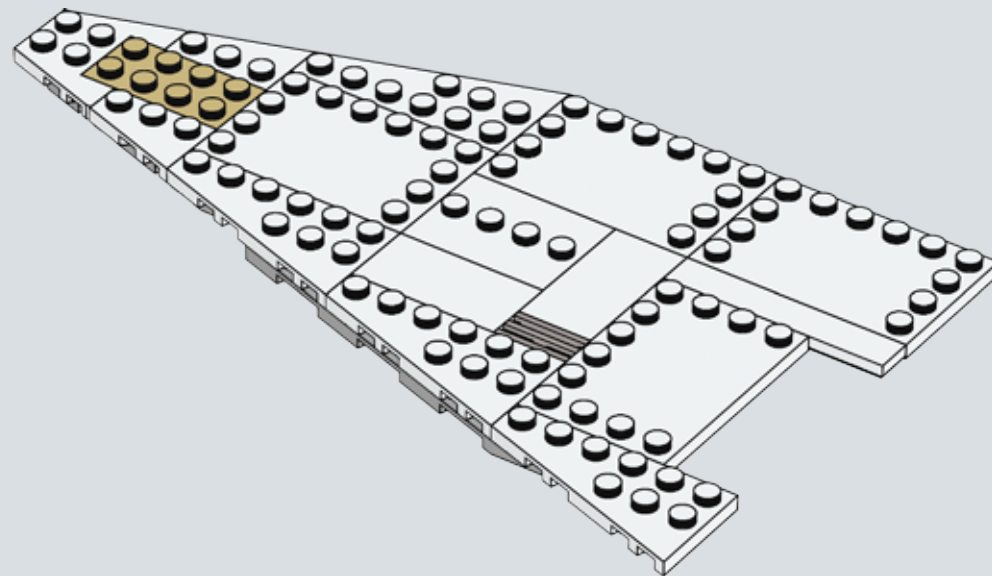

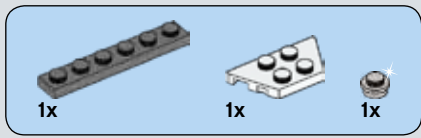

298

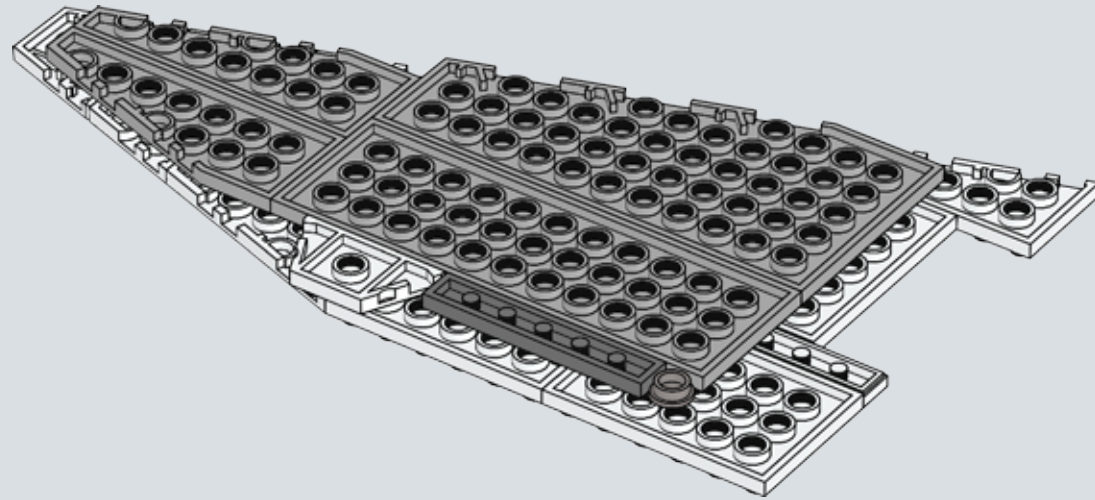
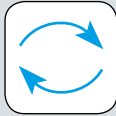

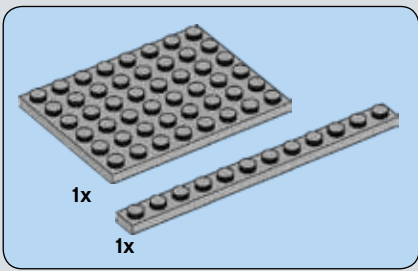

299

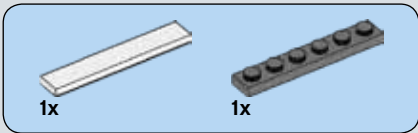
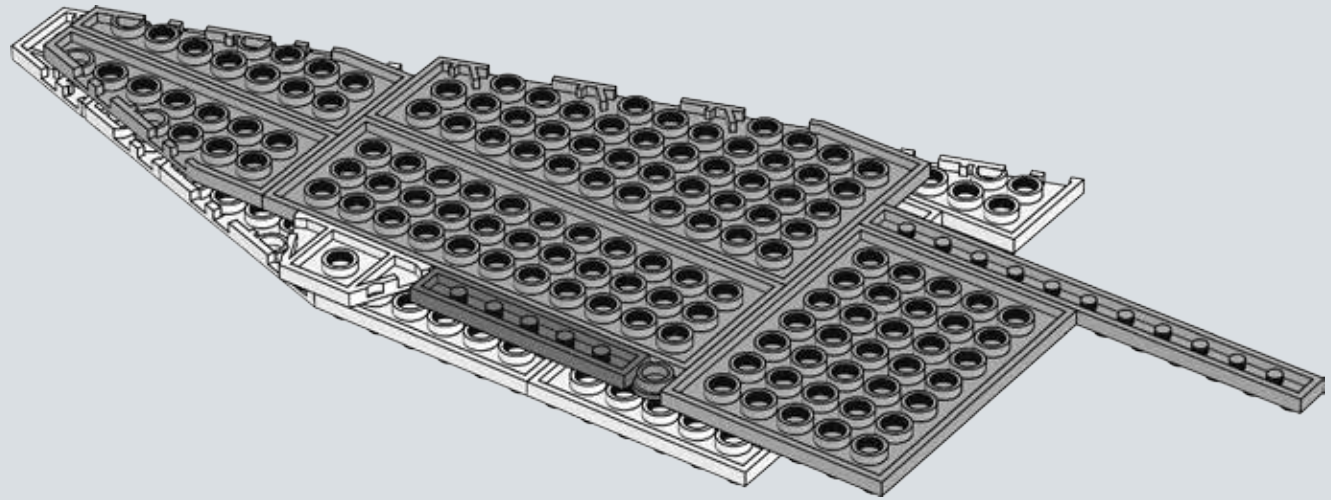

300

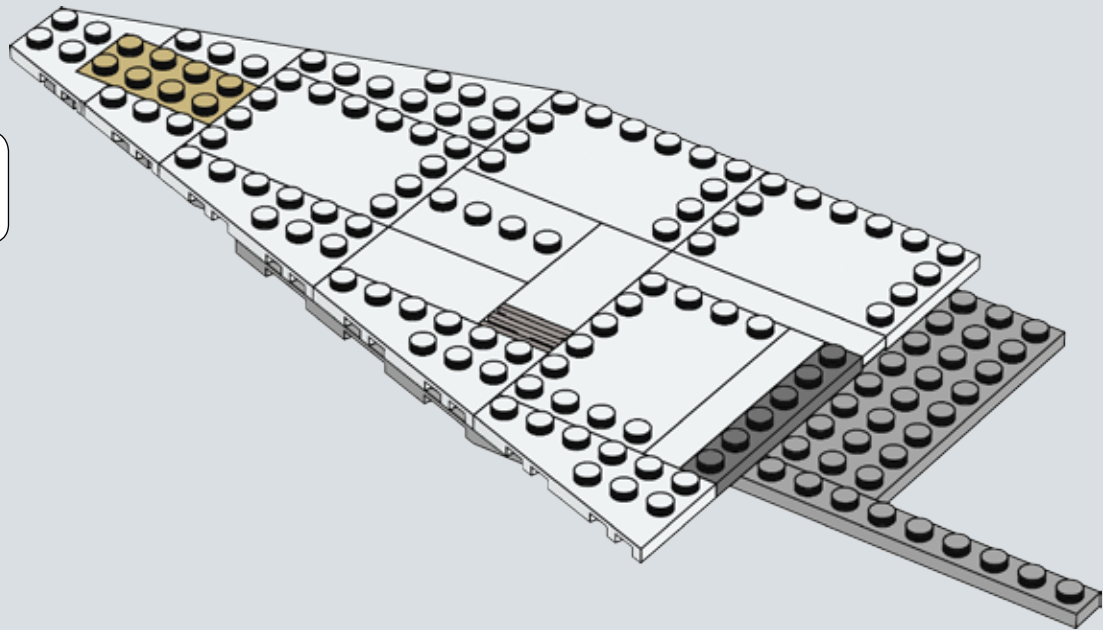
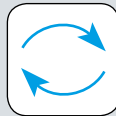

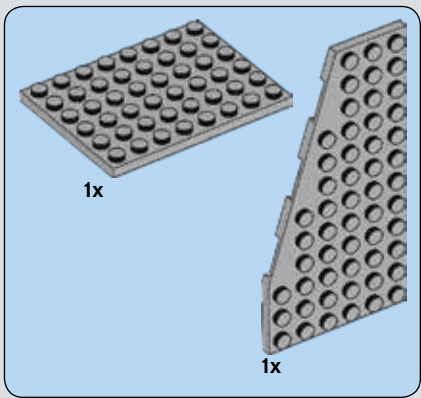

301

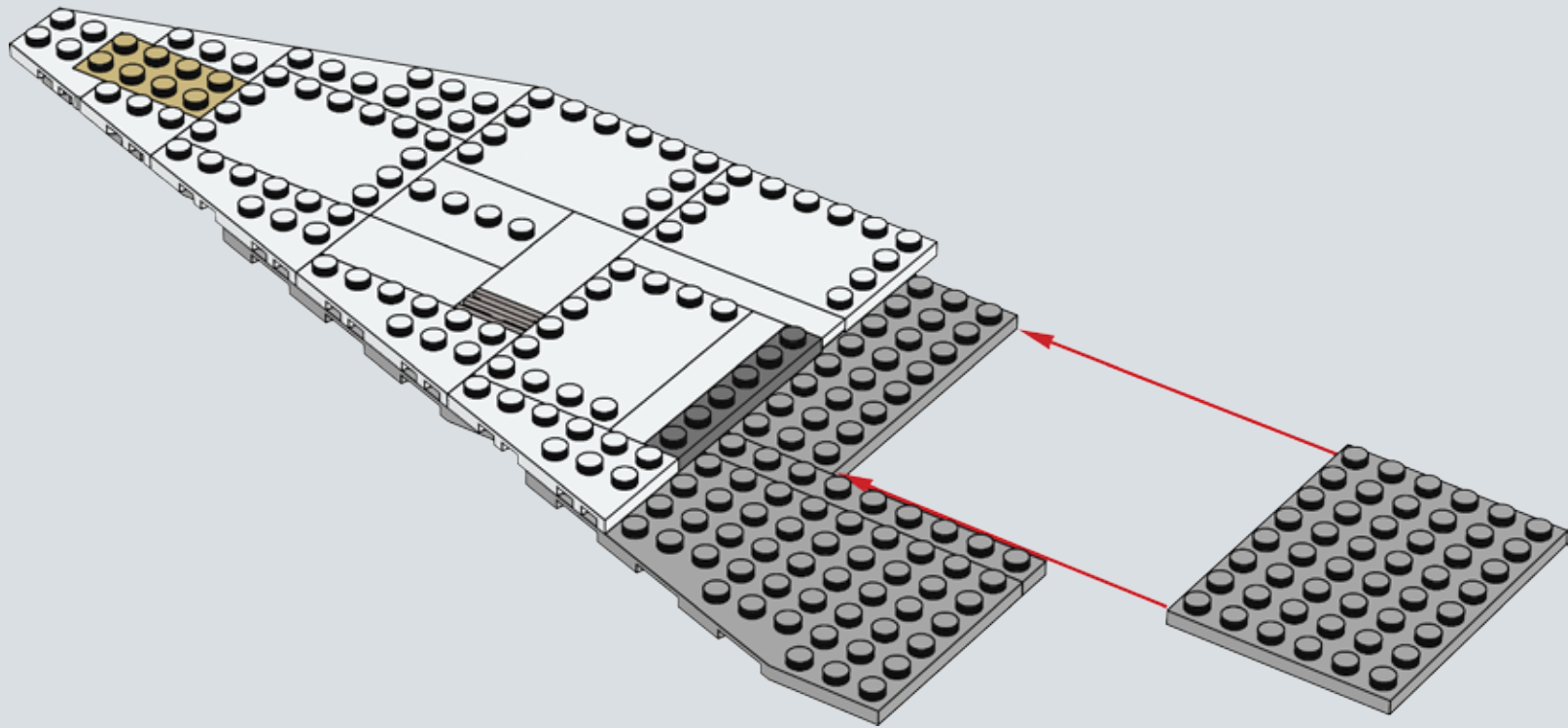

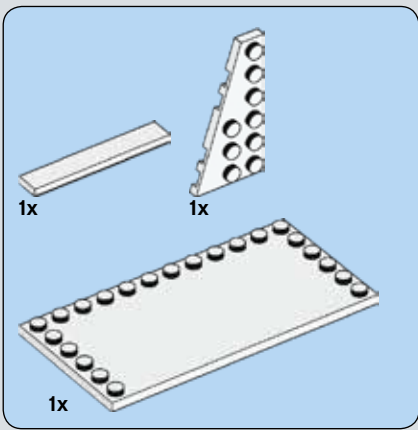

302

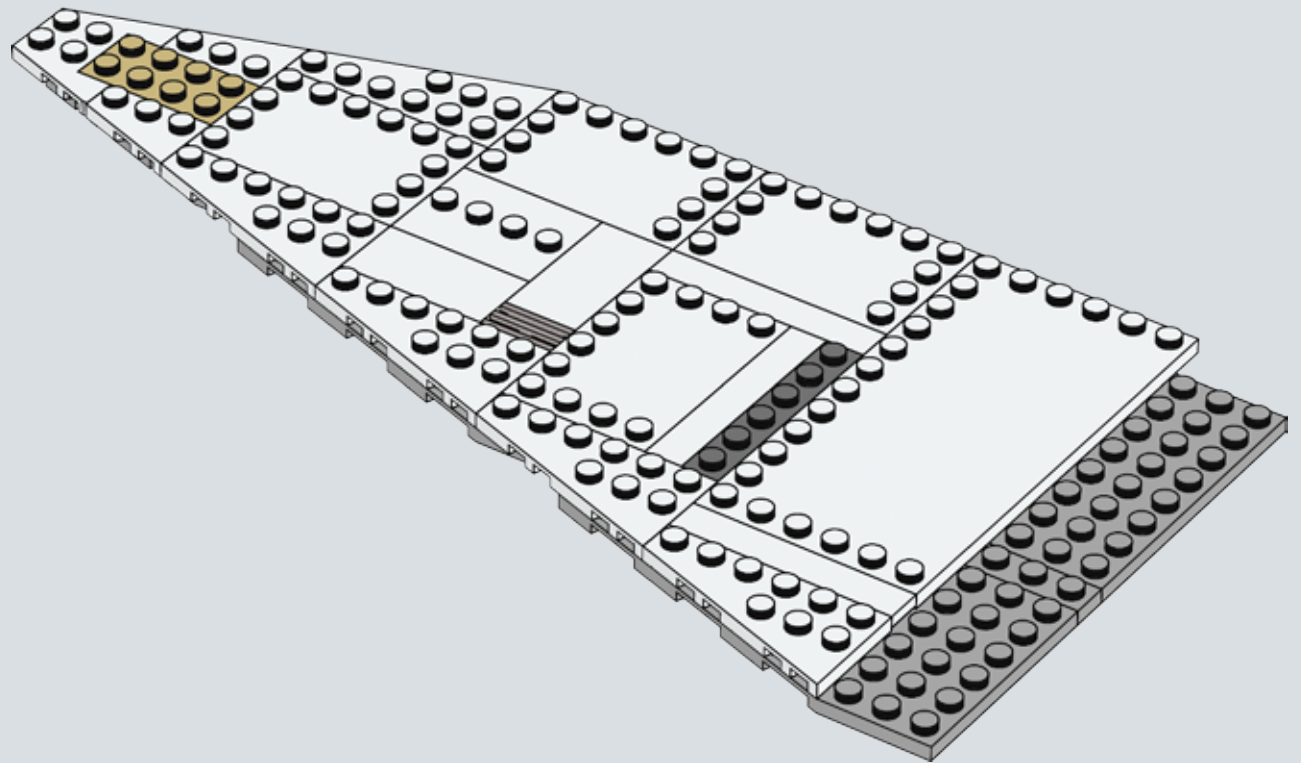

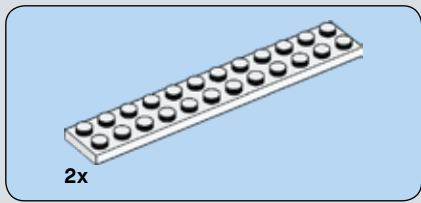

303

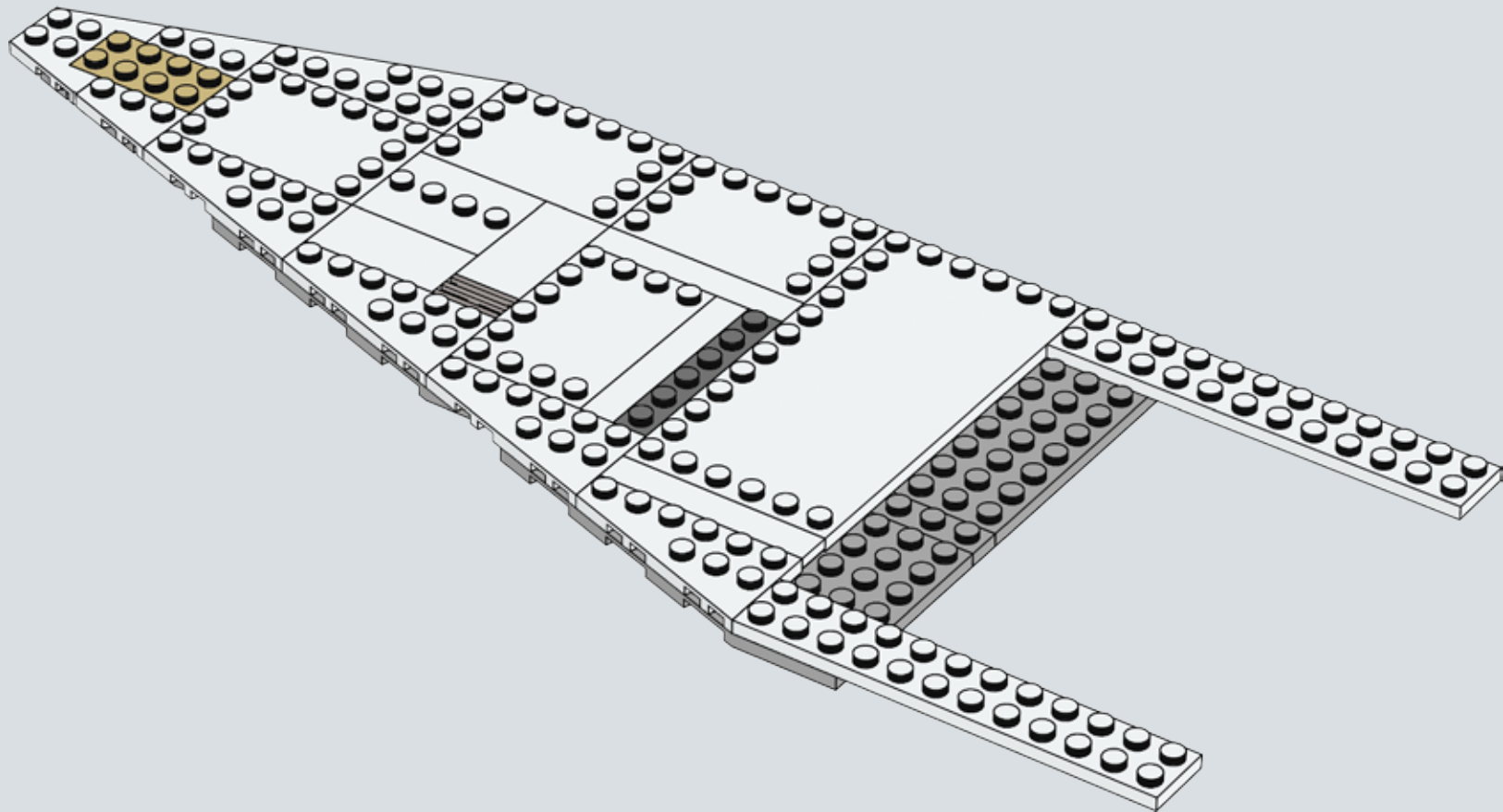

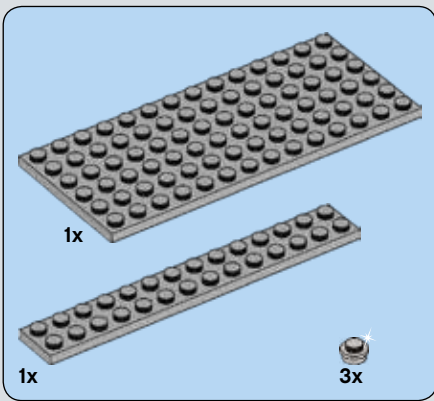

304

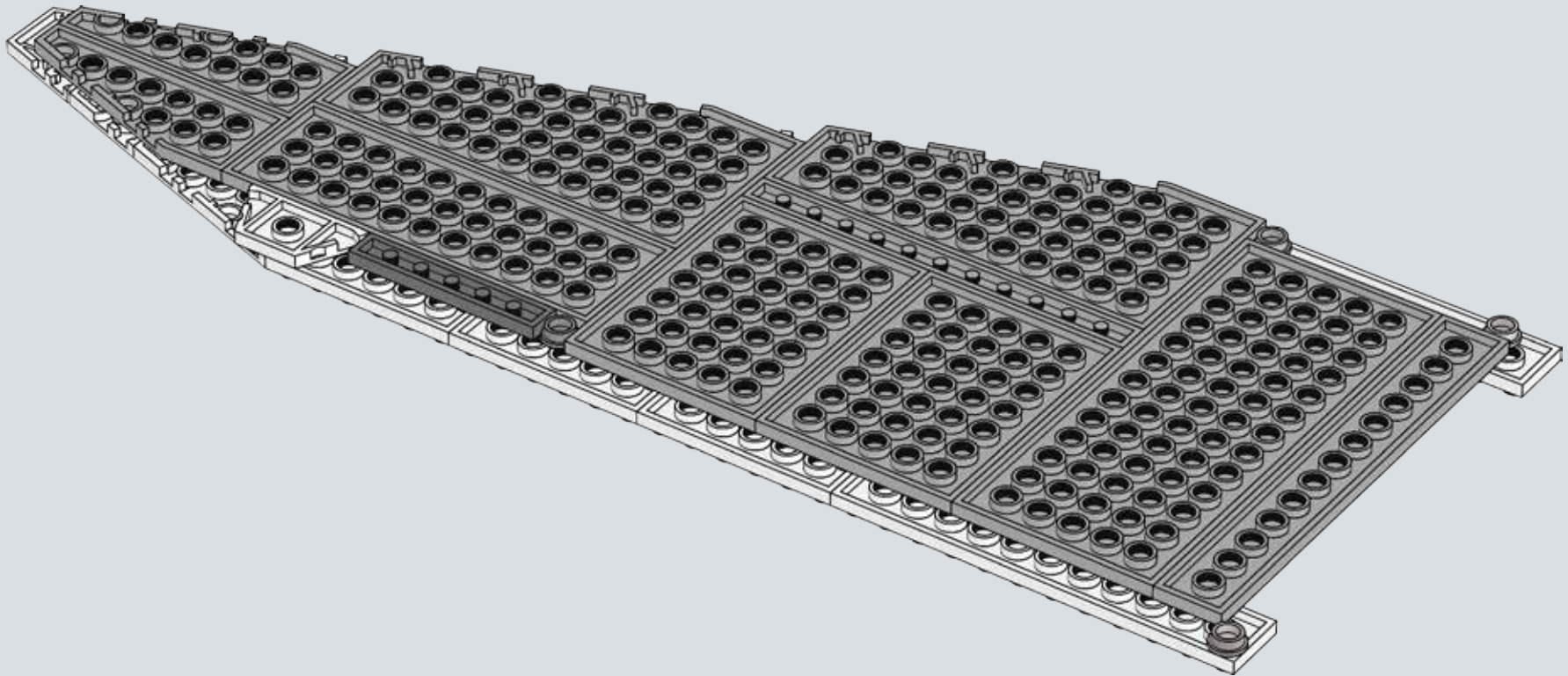

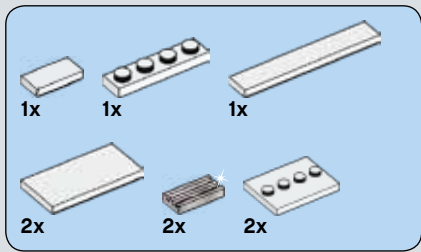

305

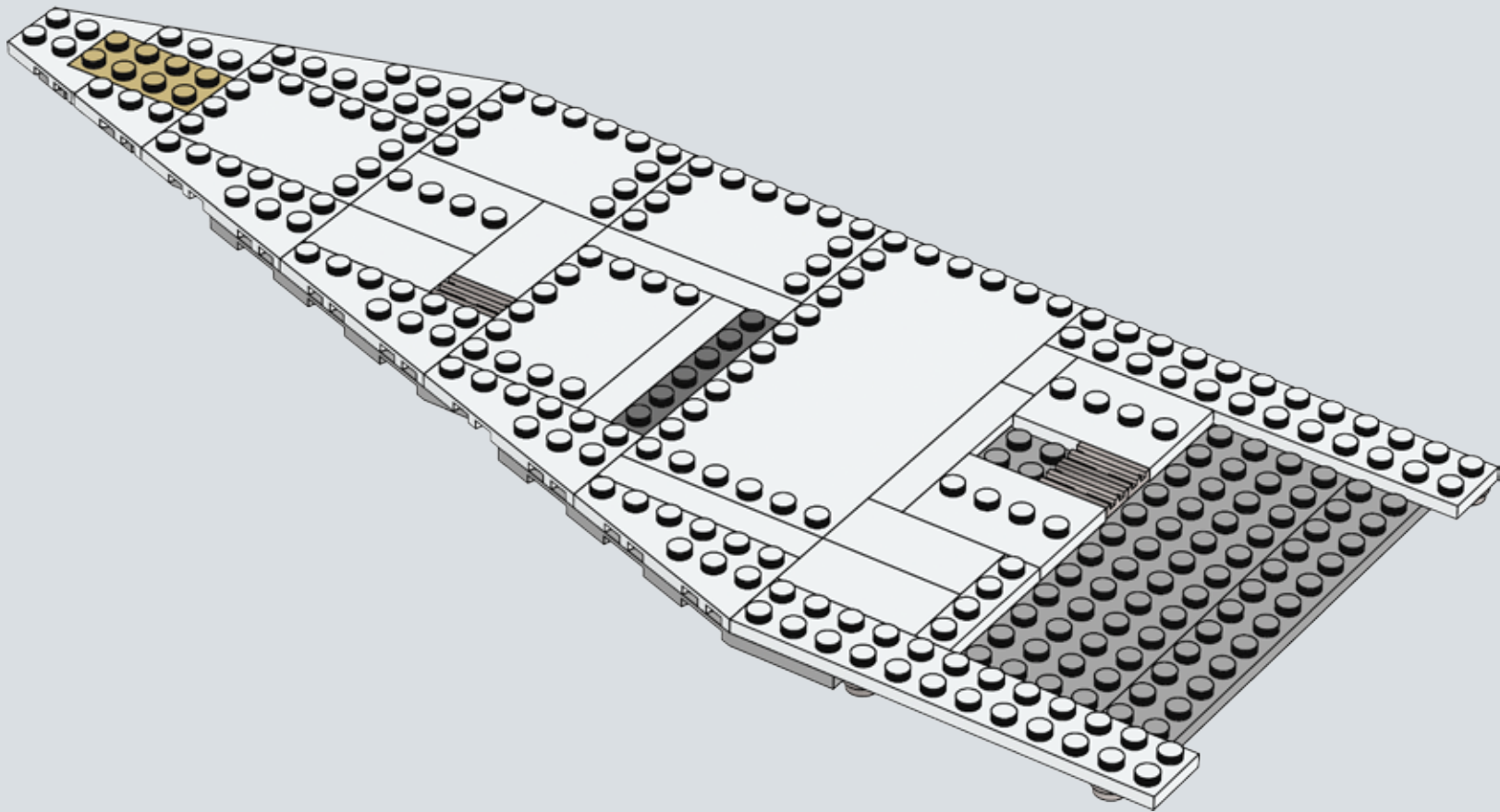

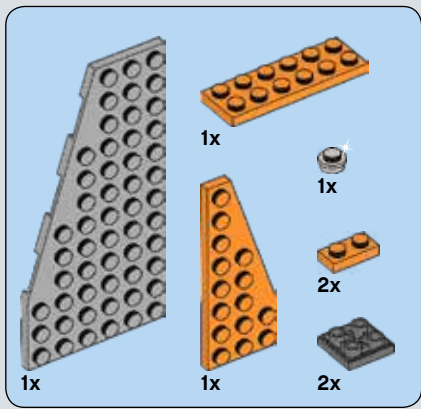

307

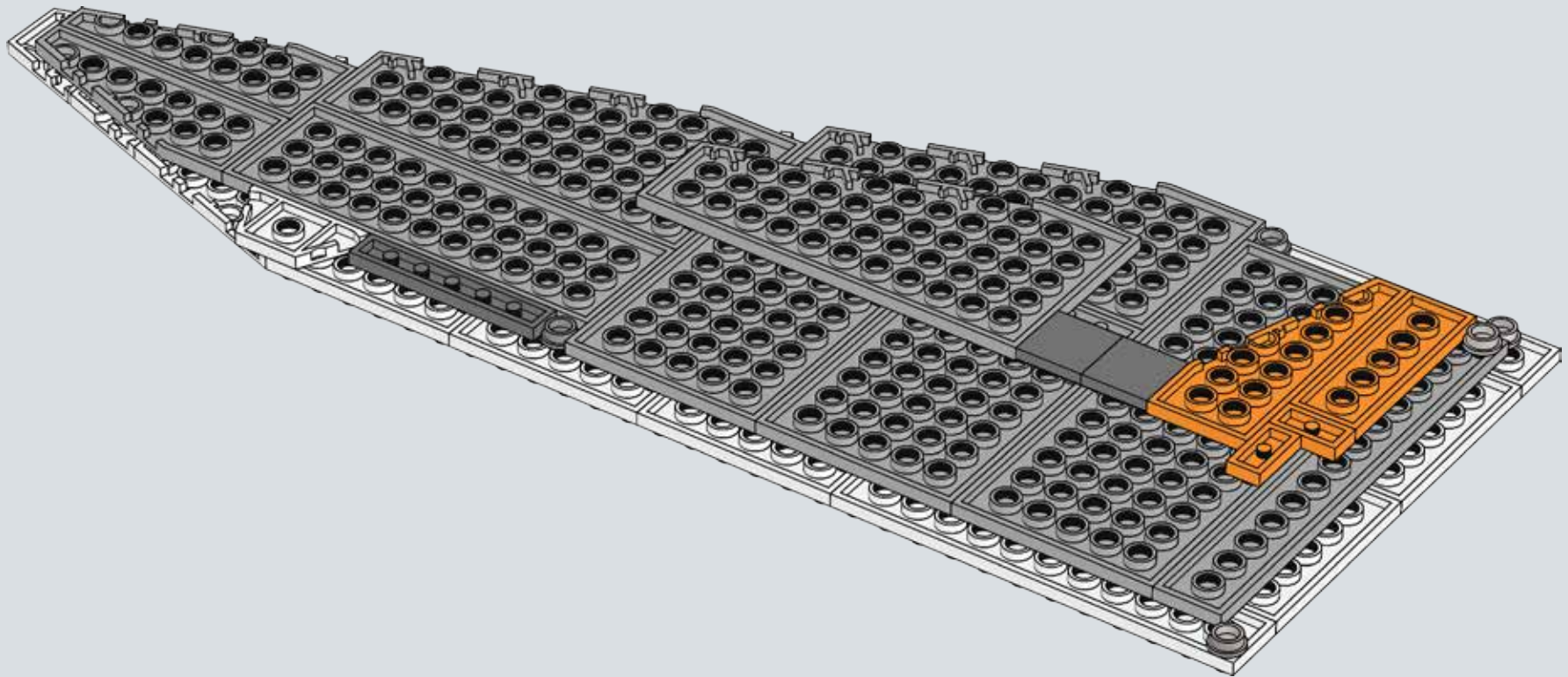
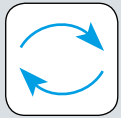

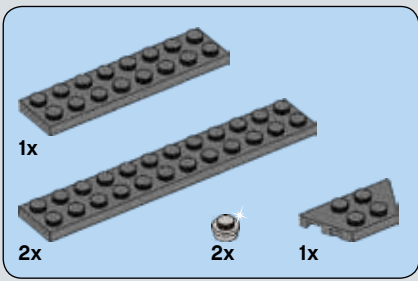

308

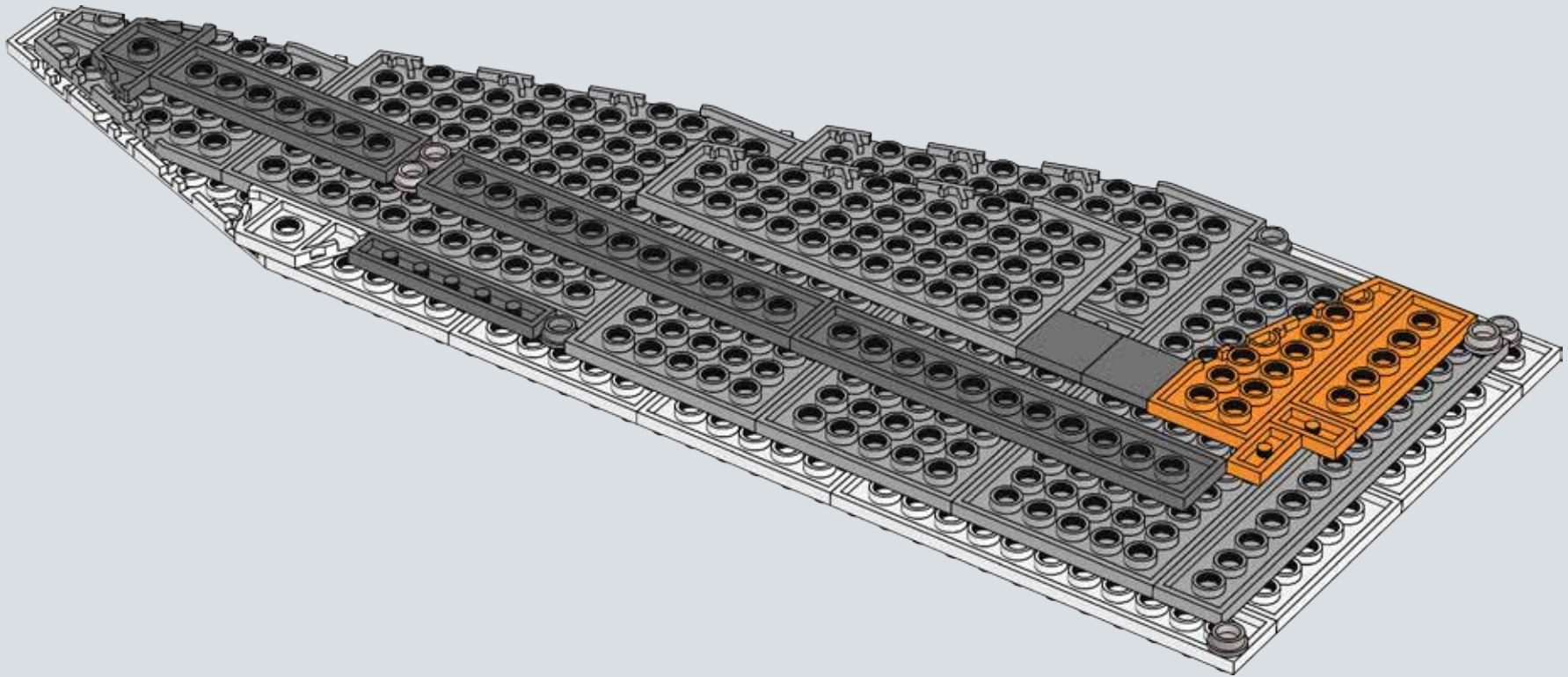

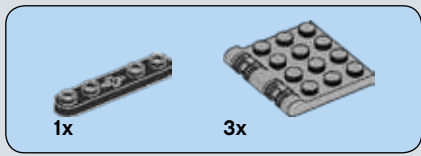

309

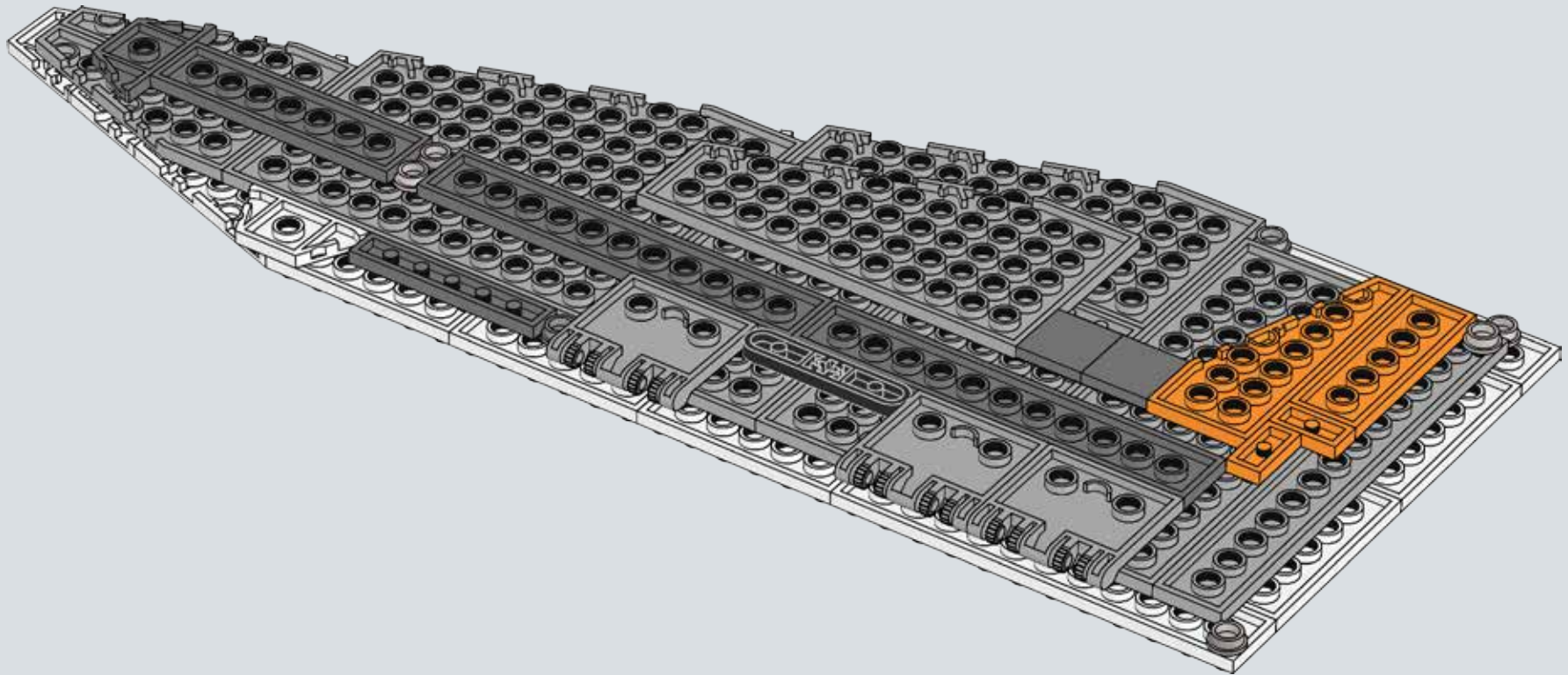

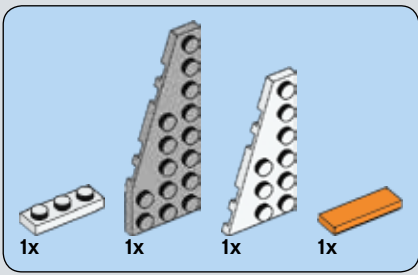

310

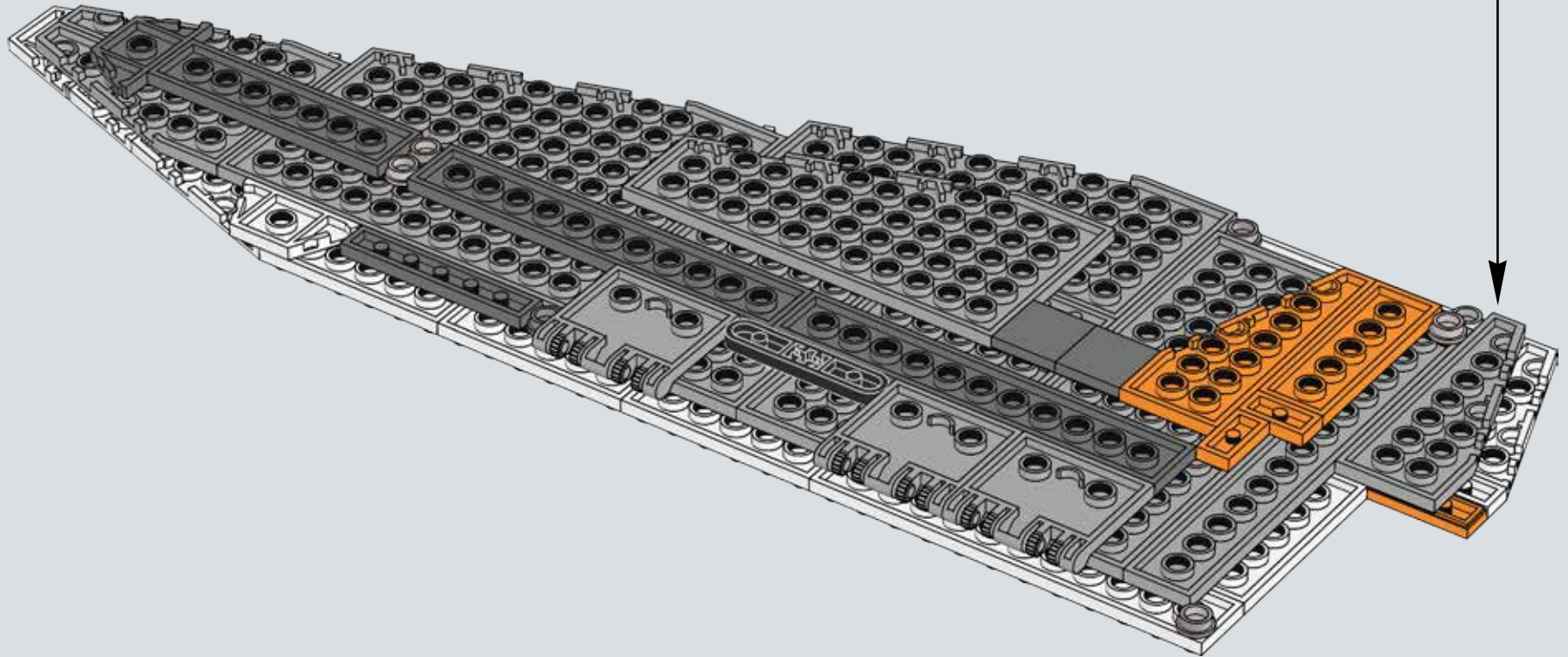
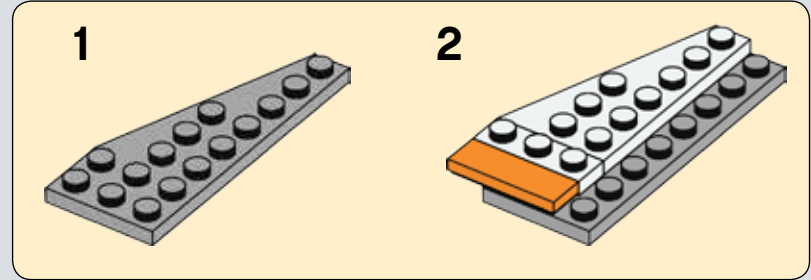

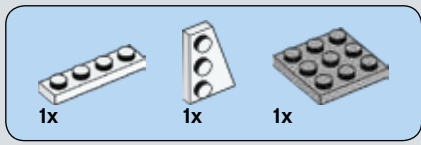

311

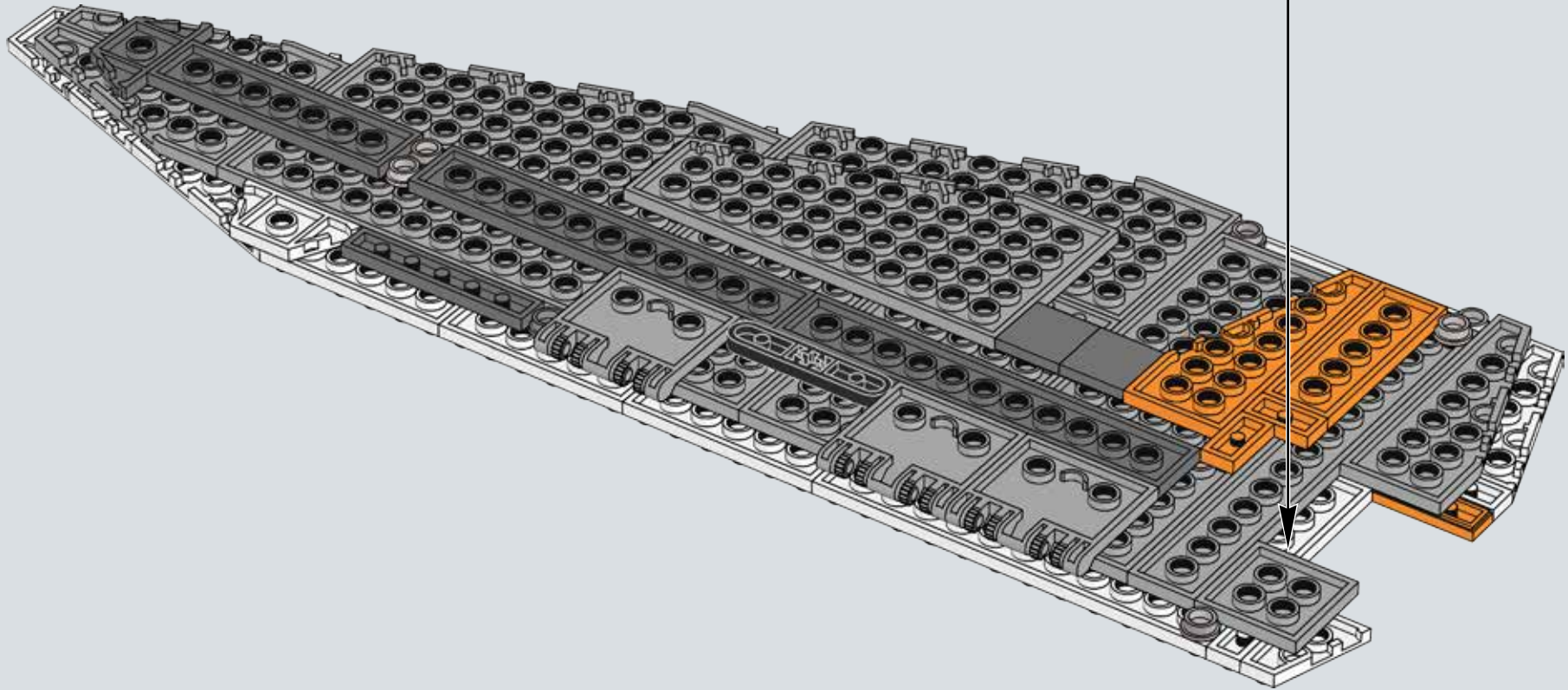
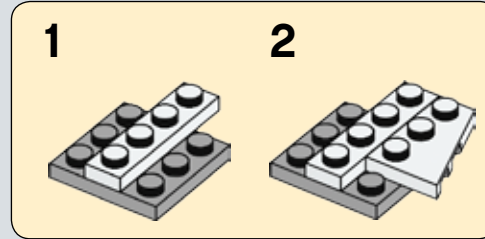



312

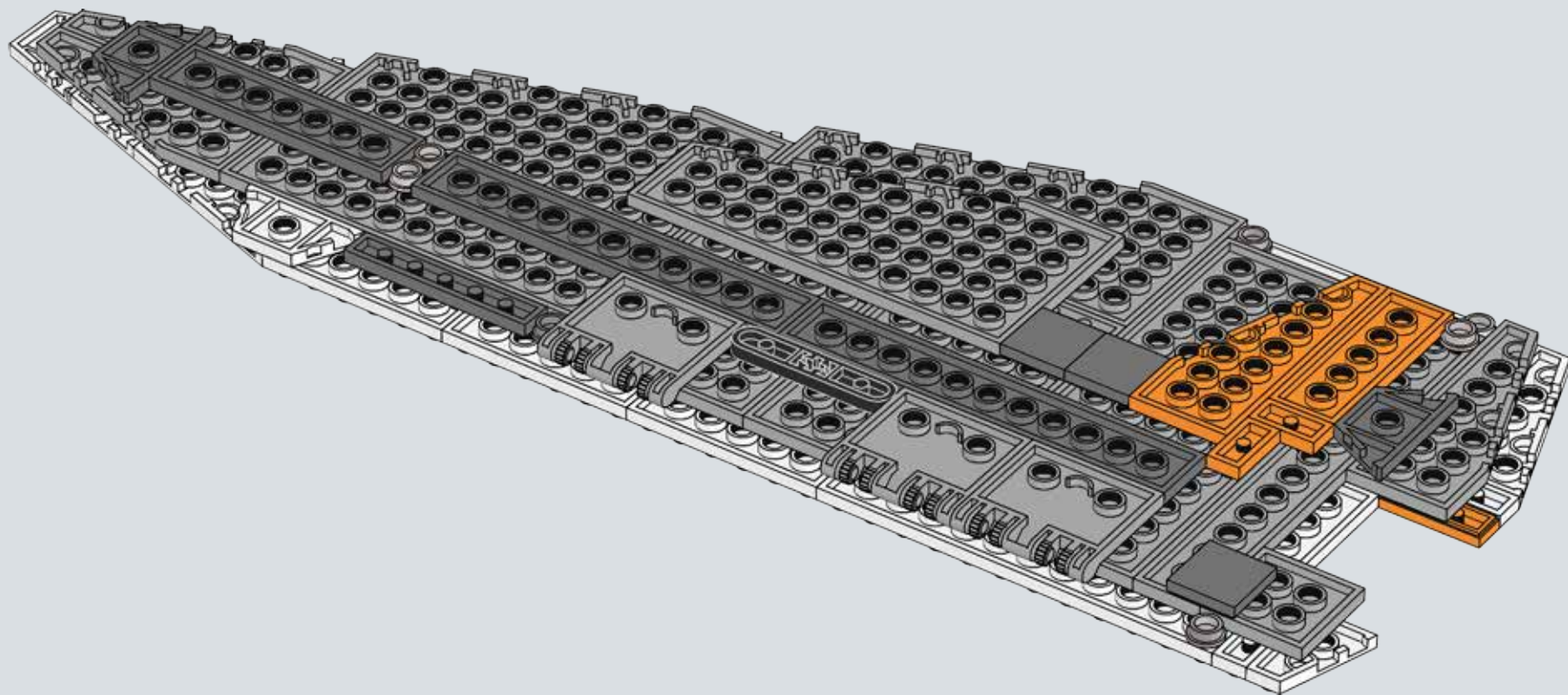



313

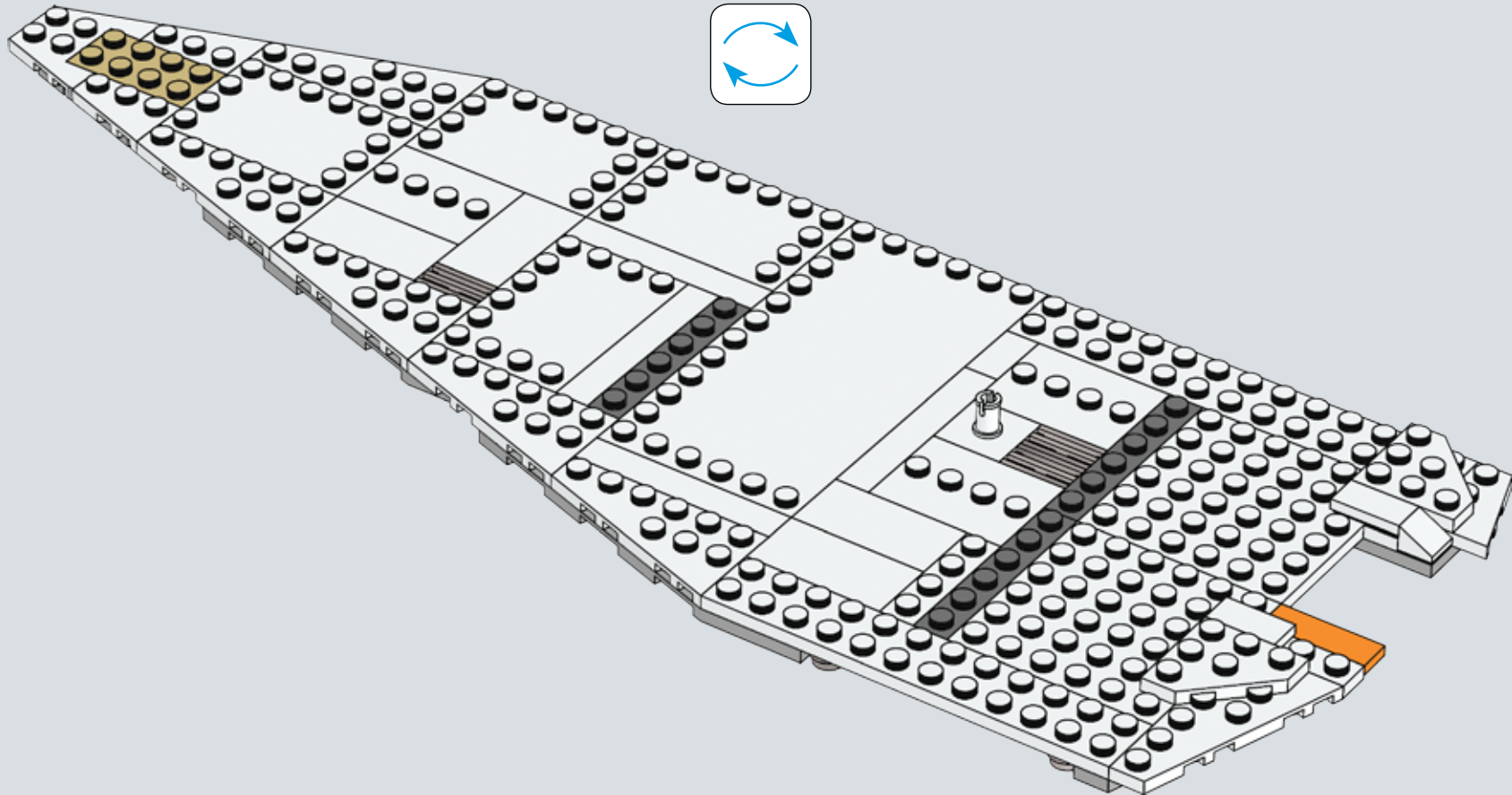
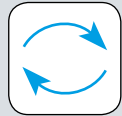

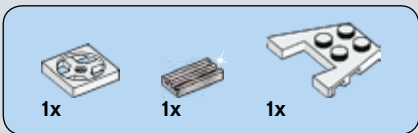

314

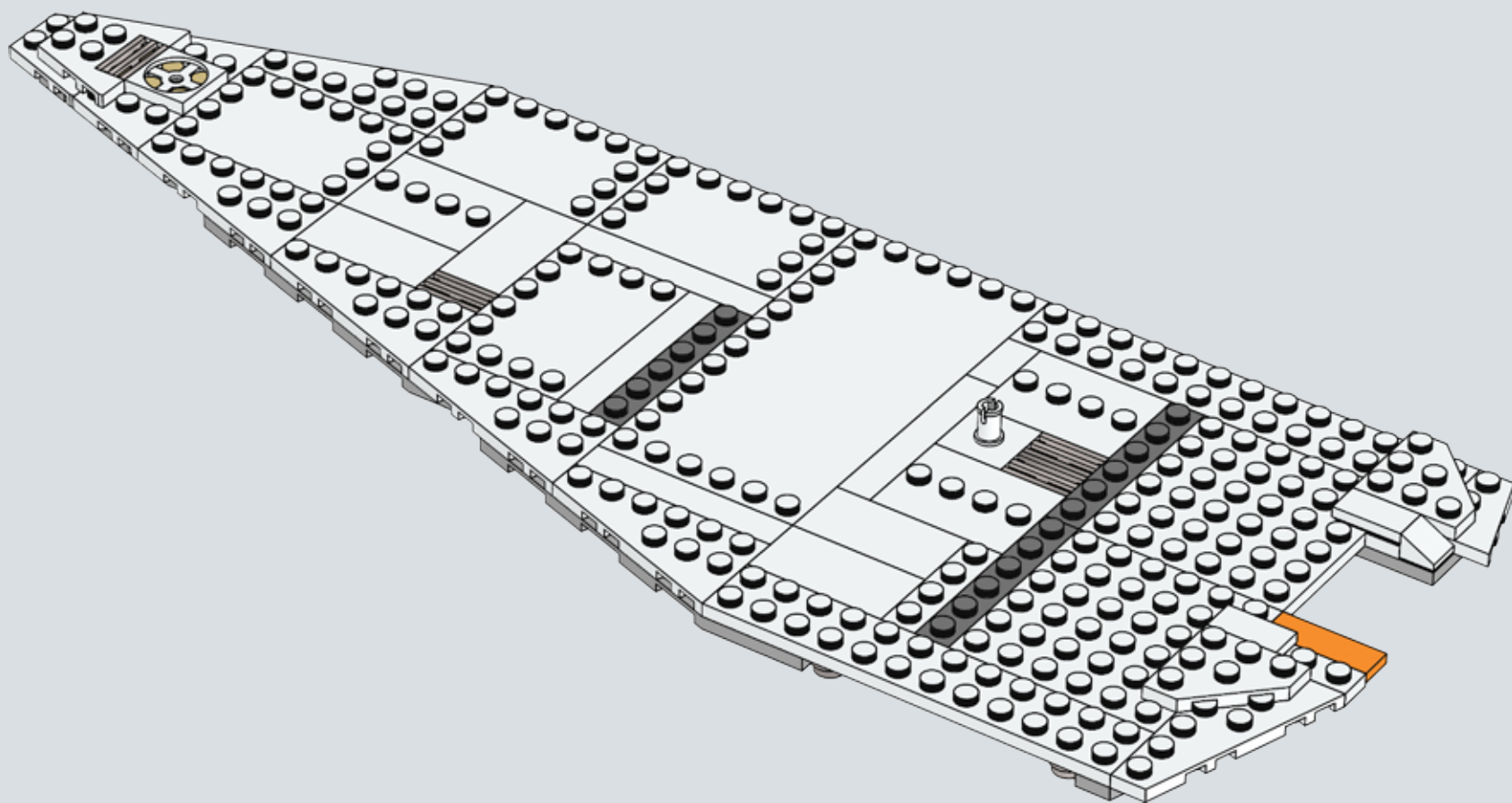



1x

315

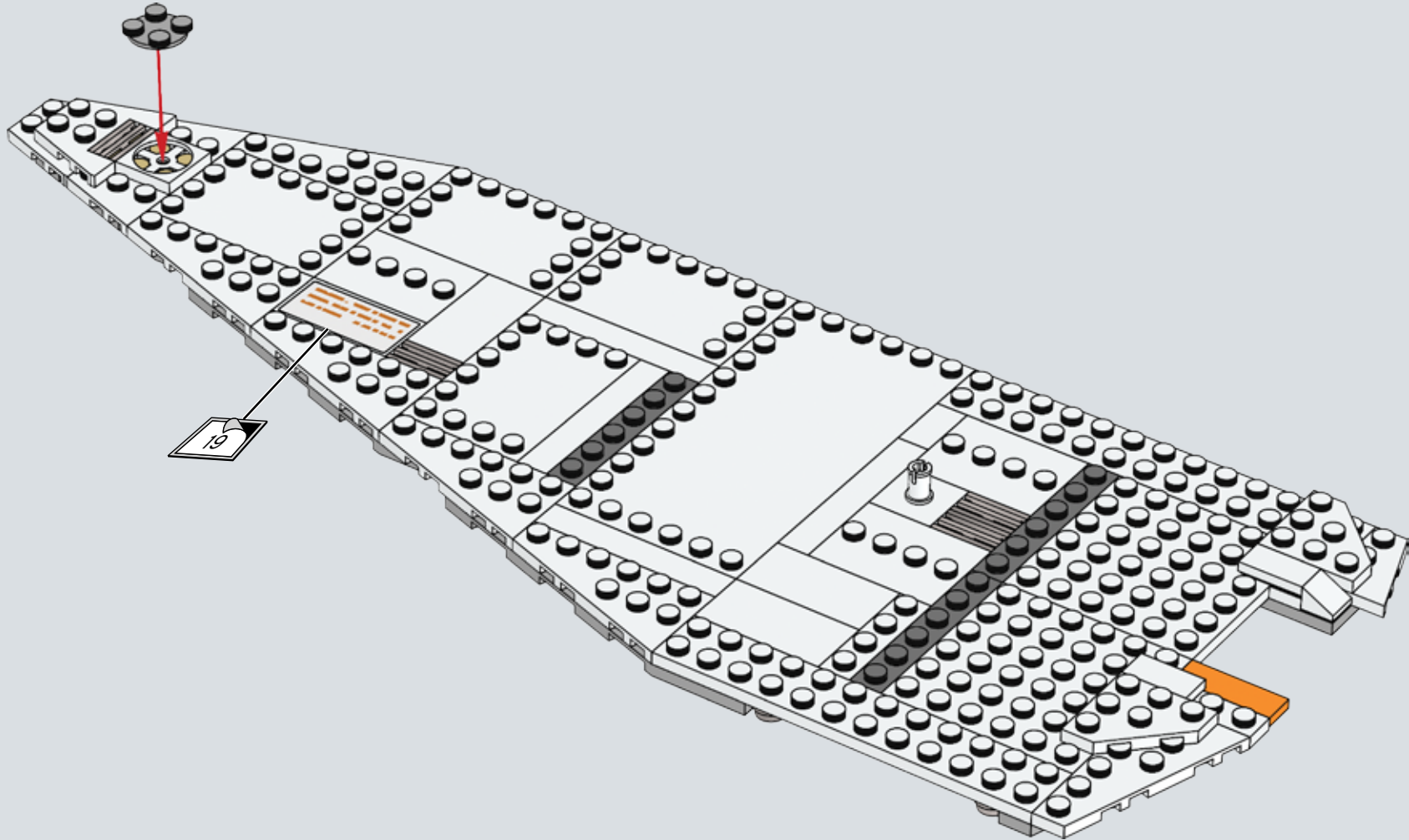

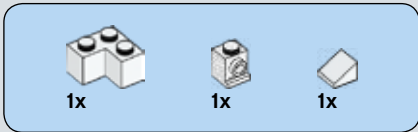
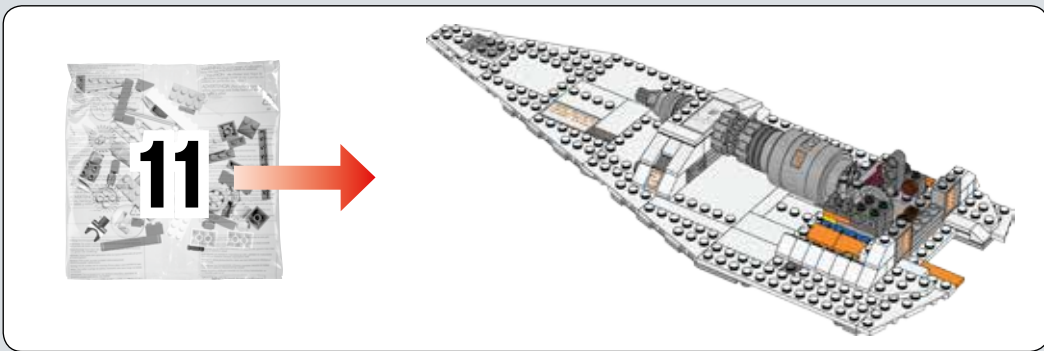

316

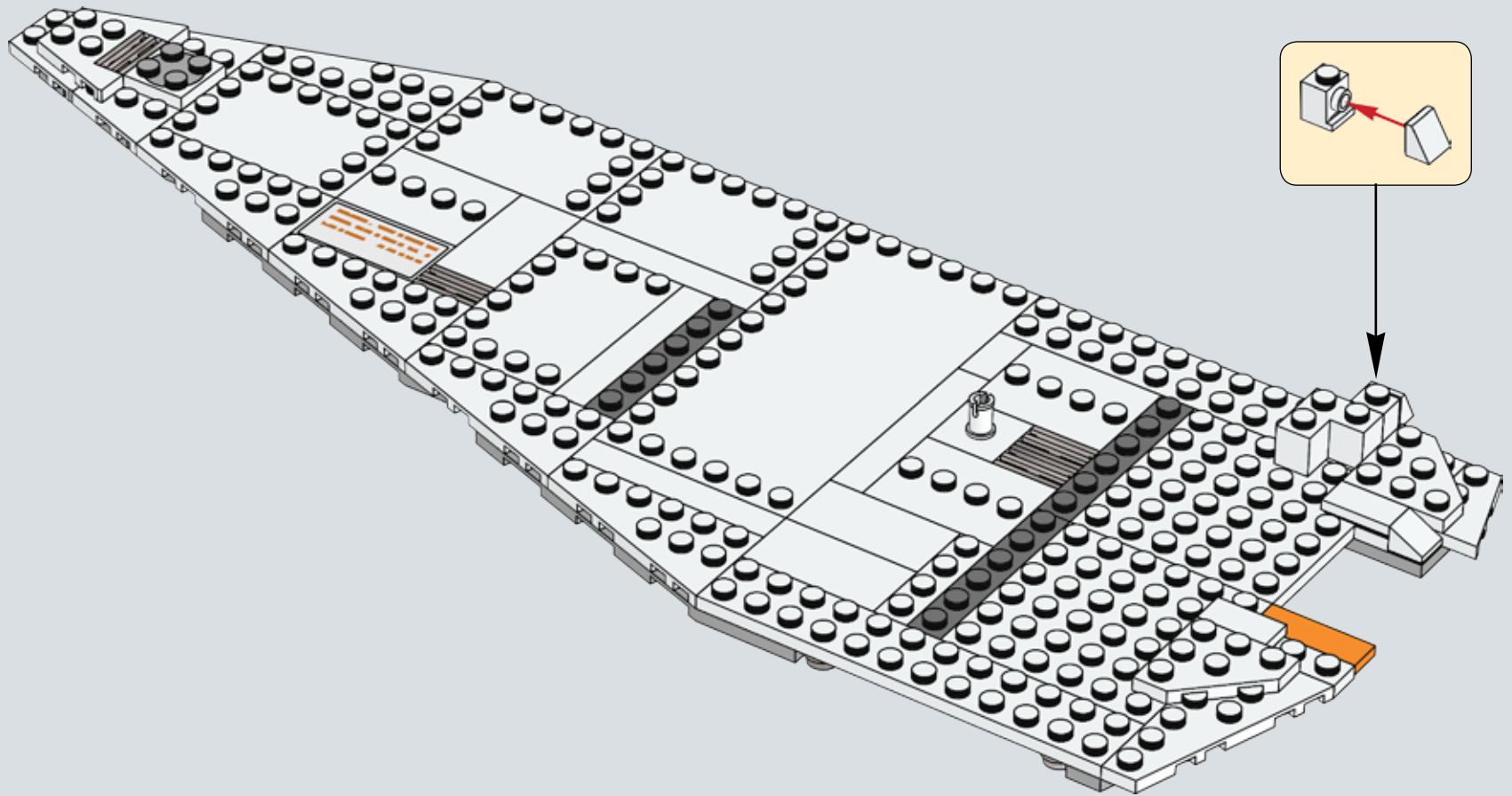

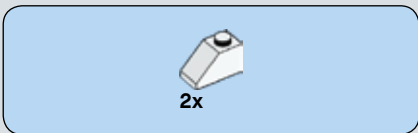

318

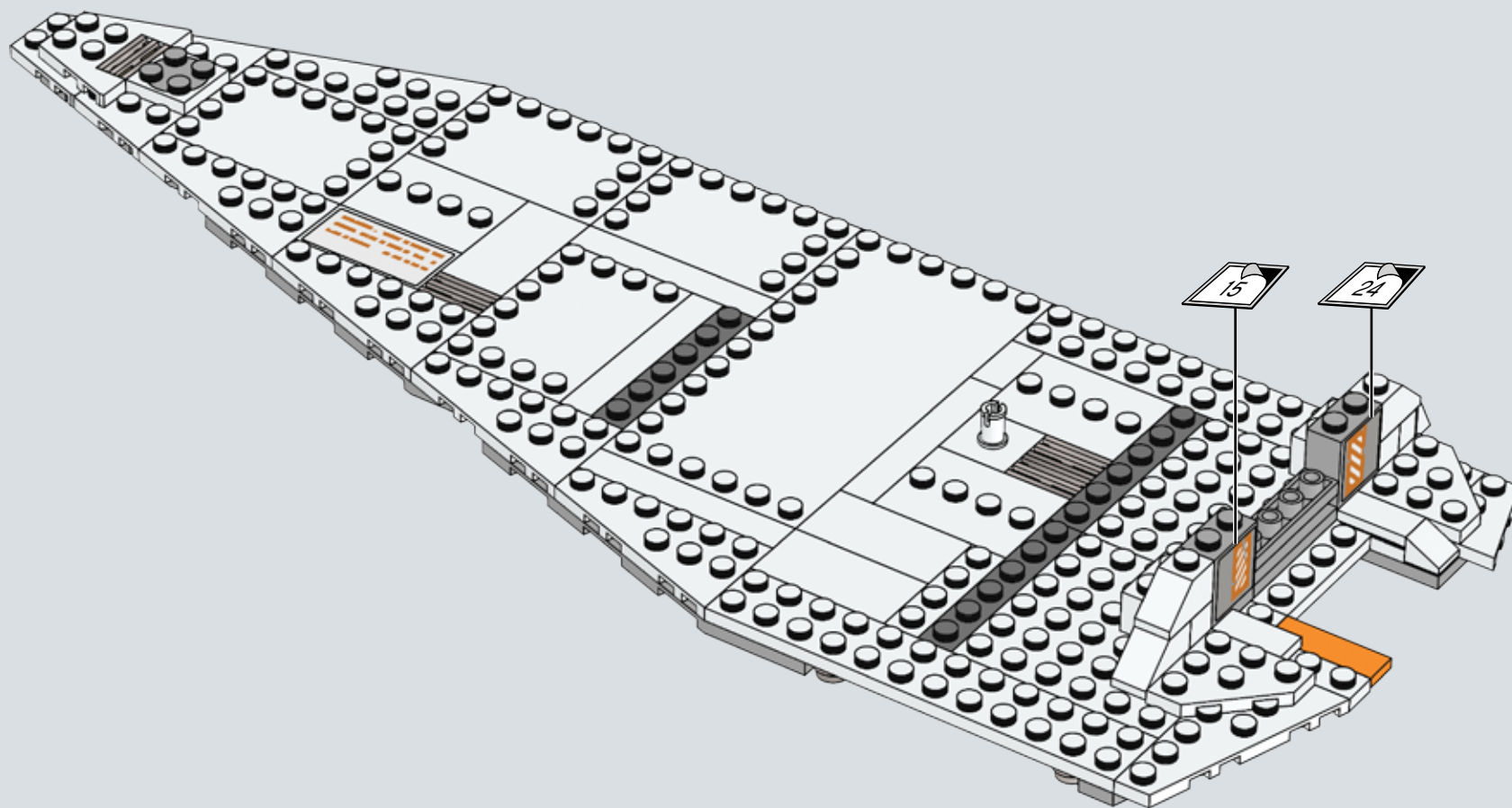



319

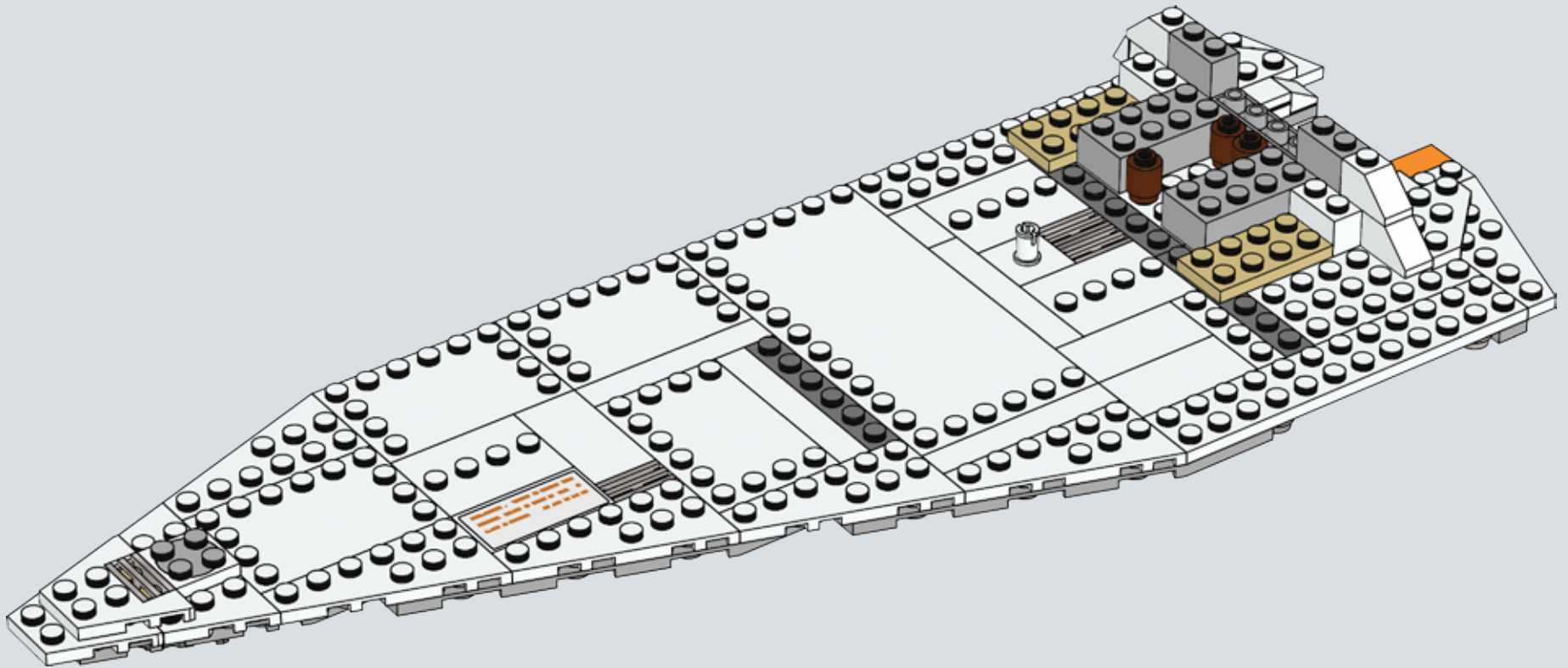



320

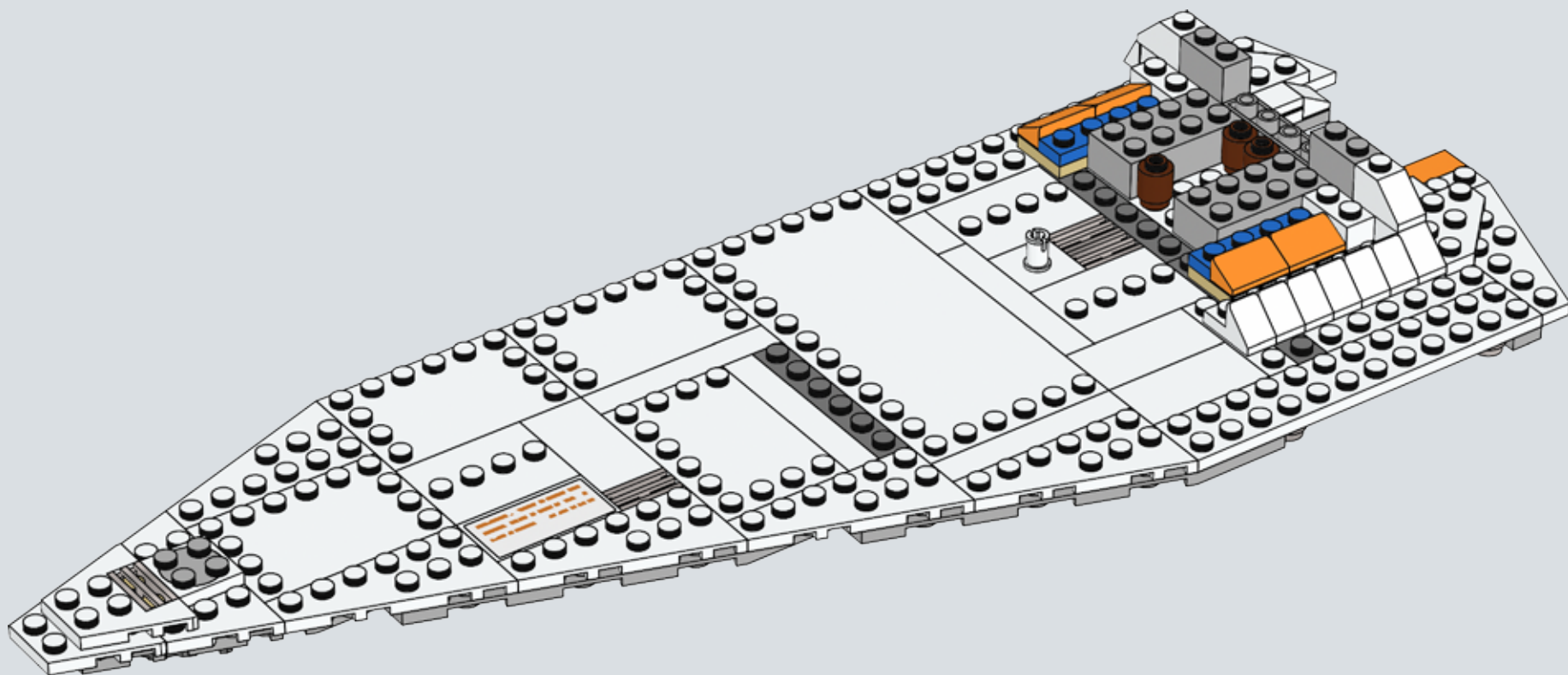

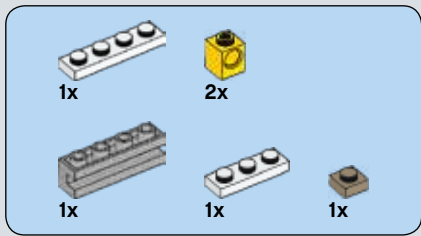

321

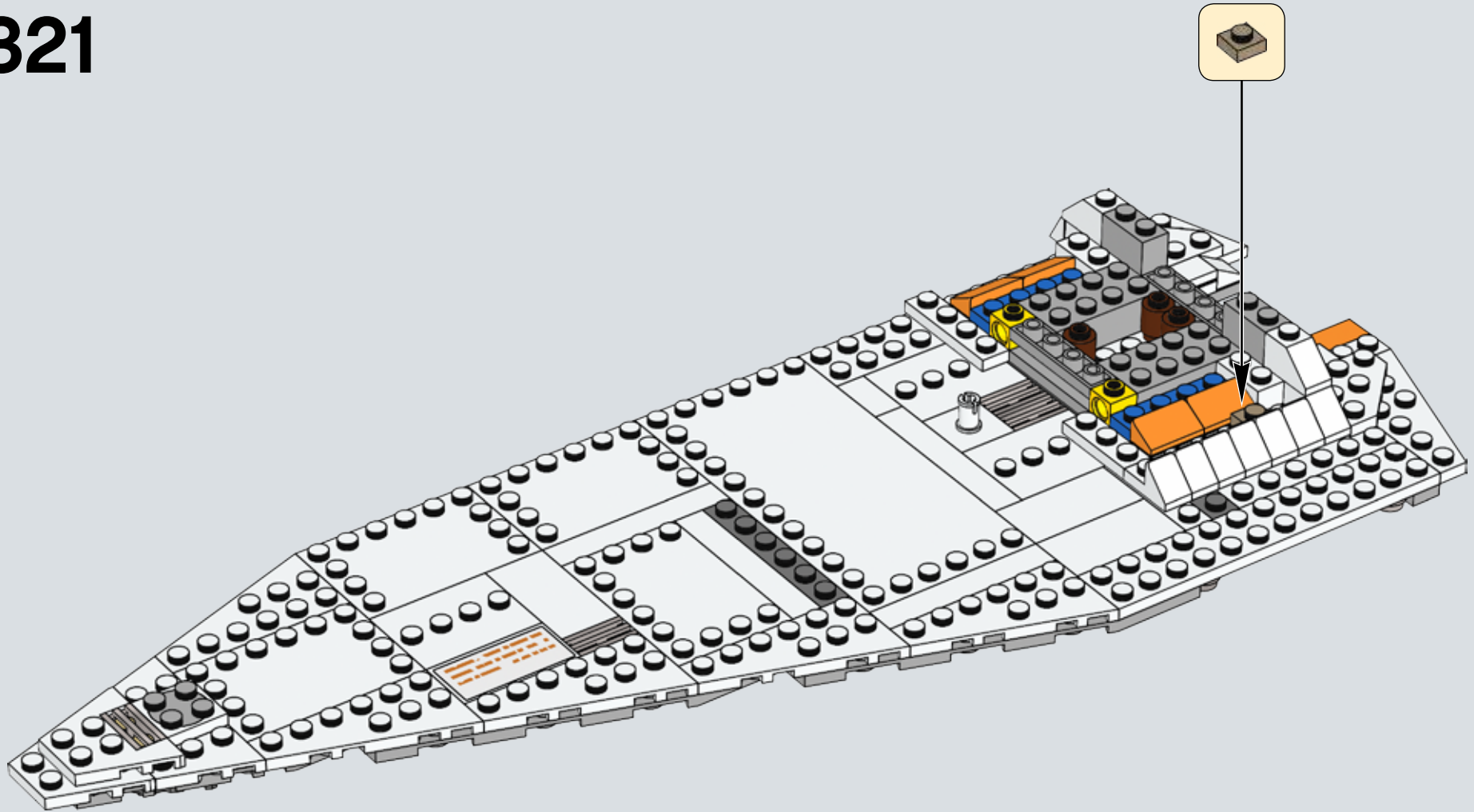



322

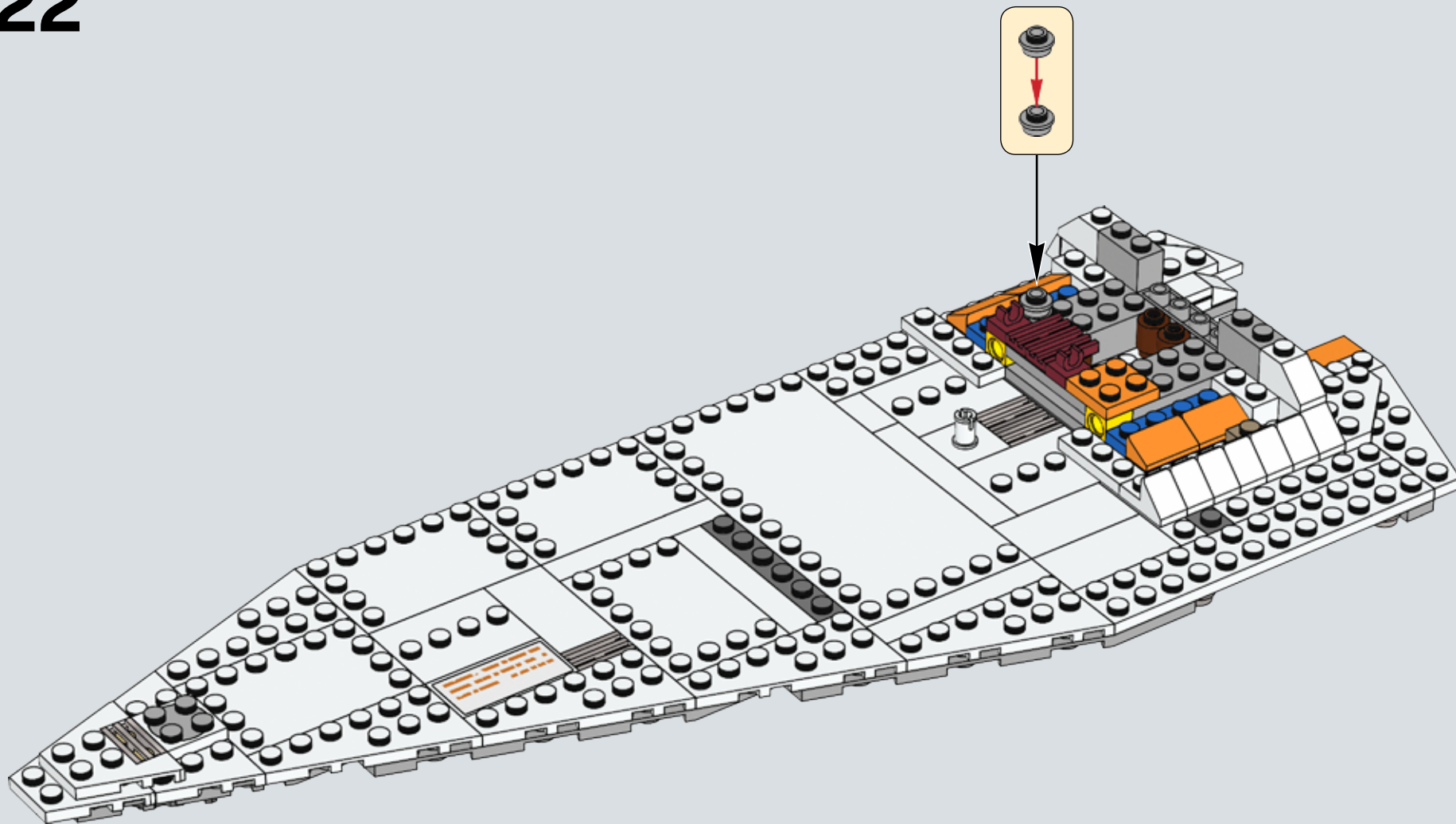



2x

323

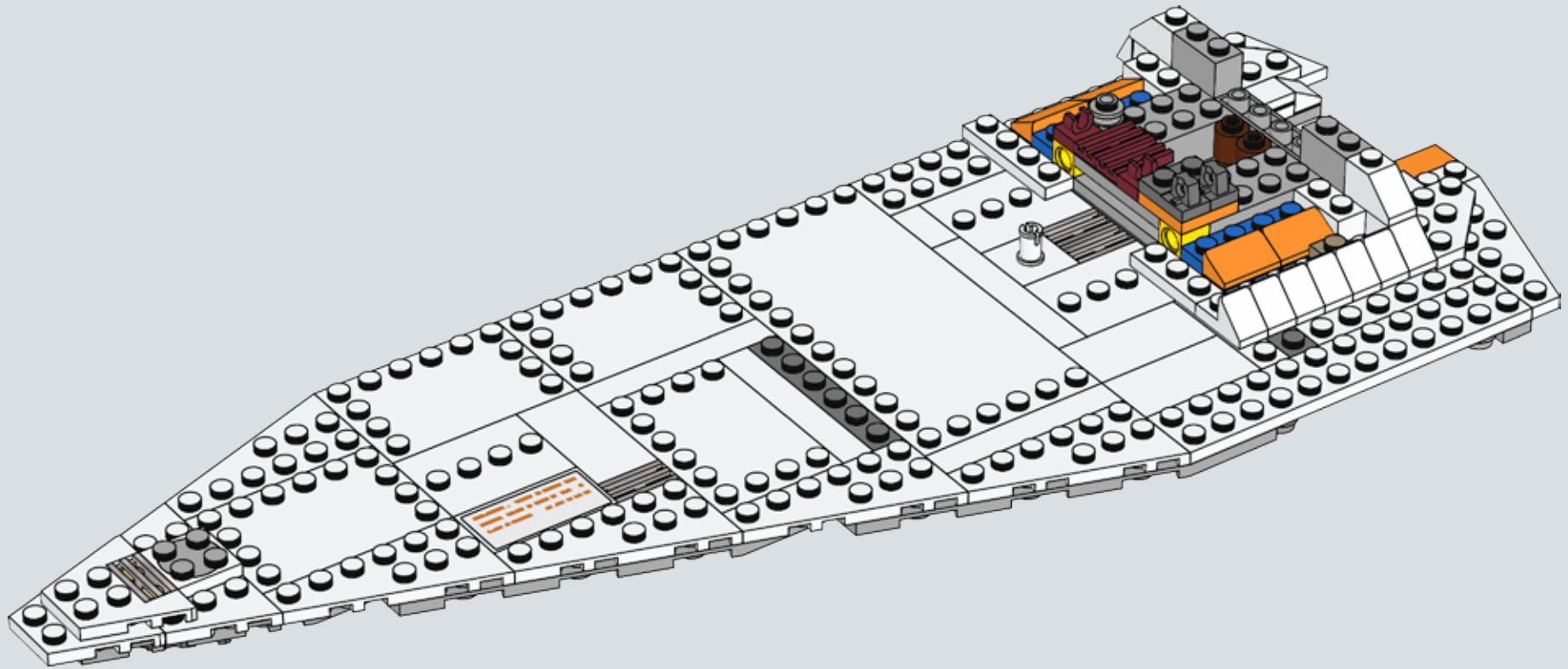

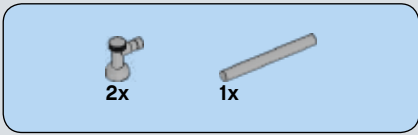

324

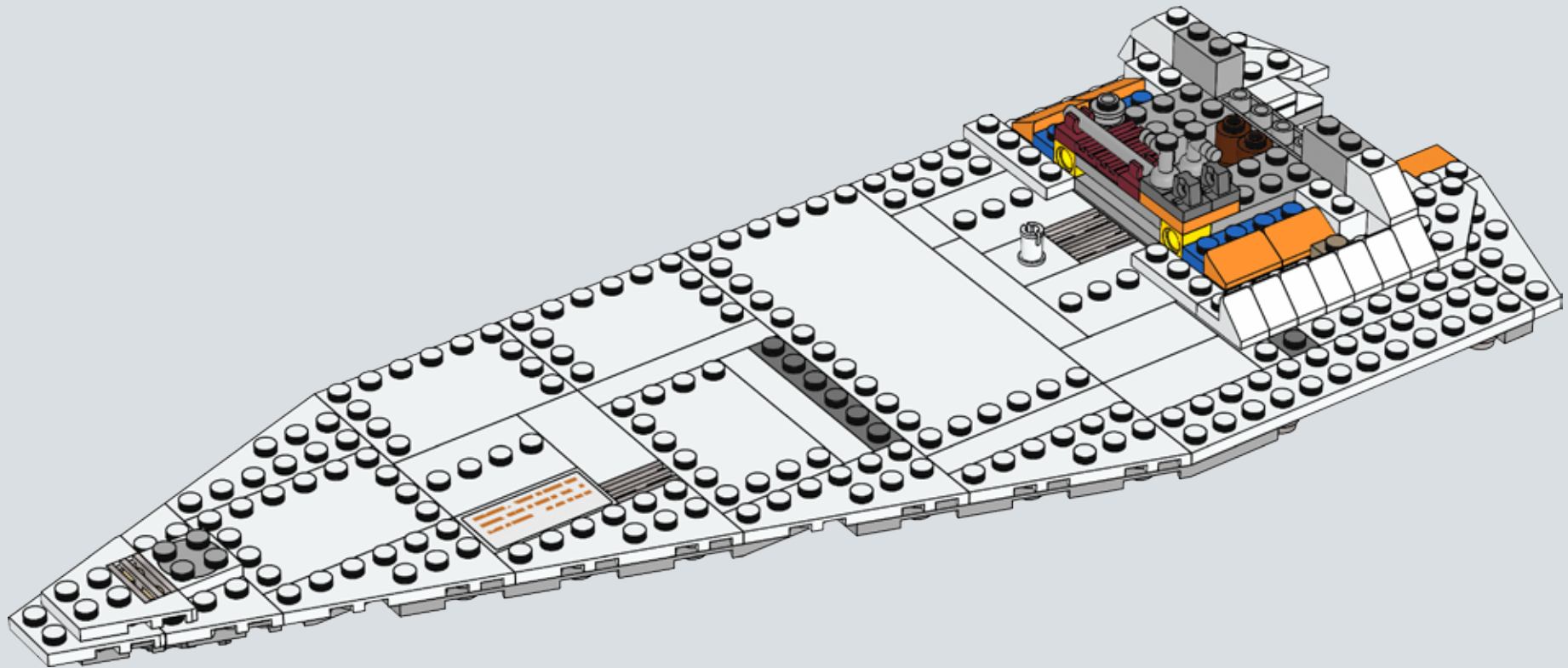

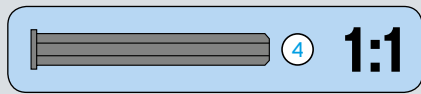
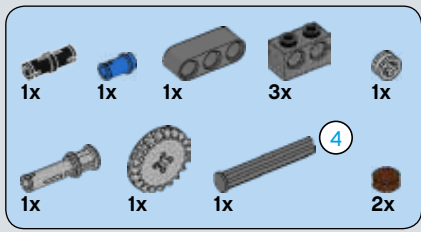

325

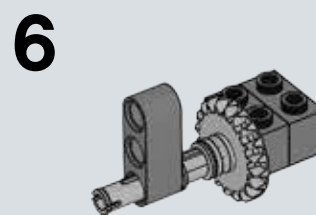
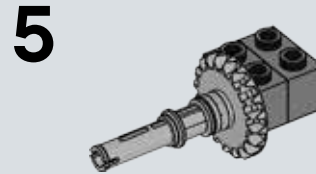
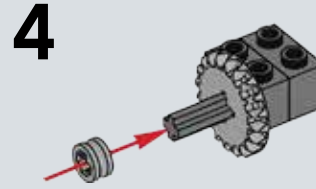
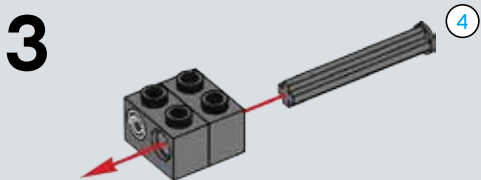
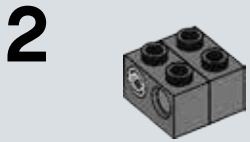
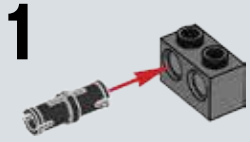

7

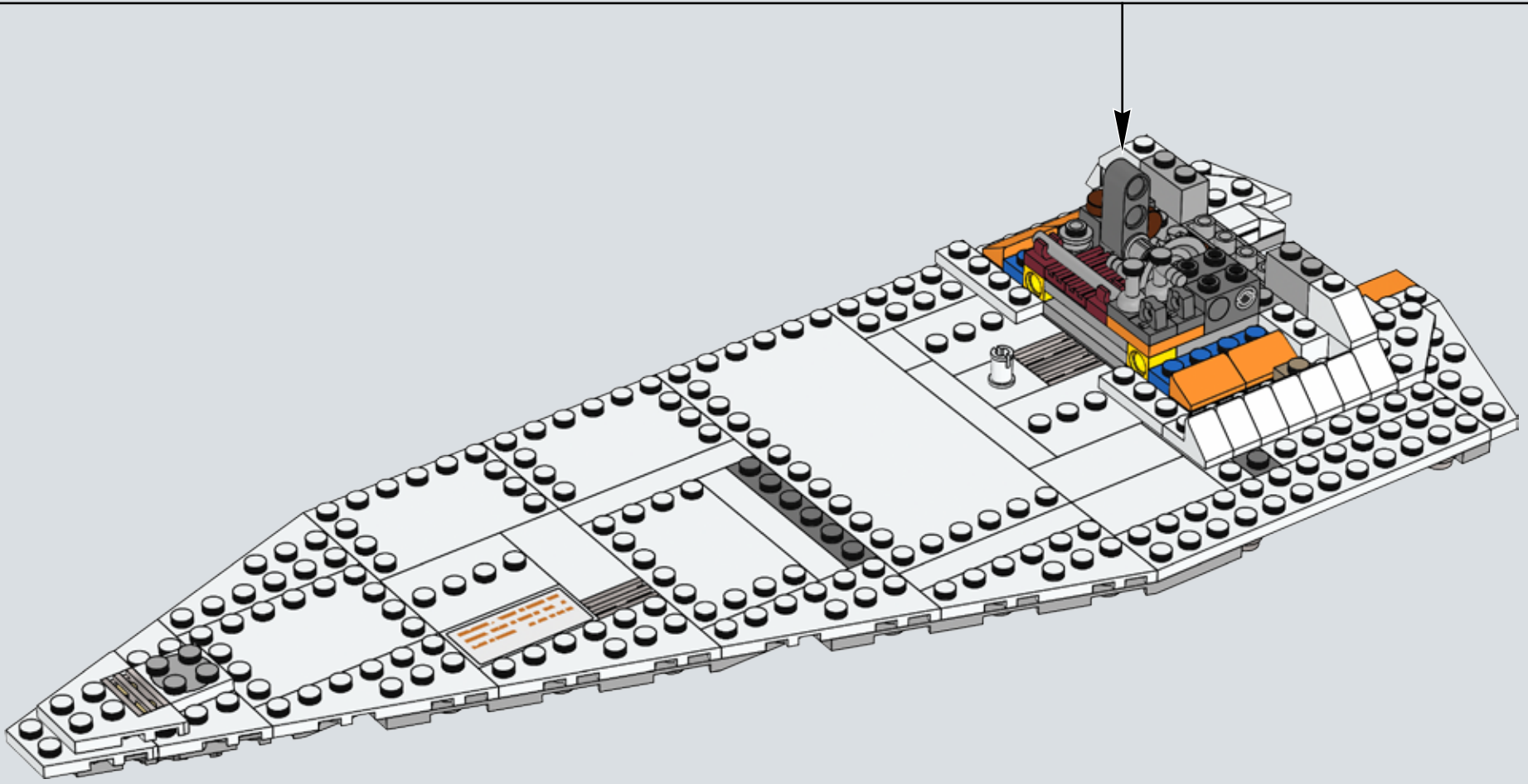
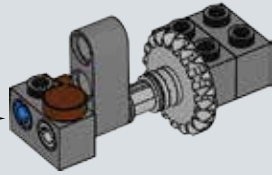
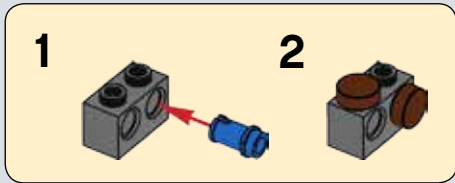

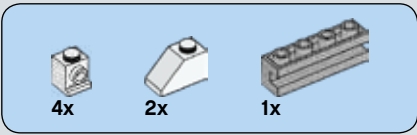

326

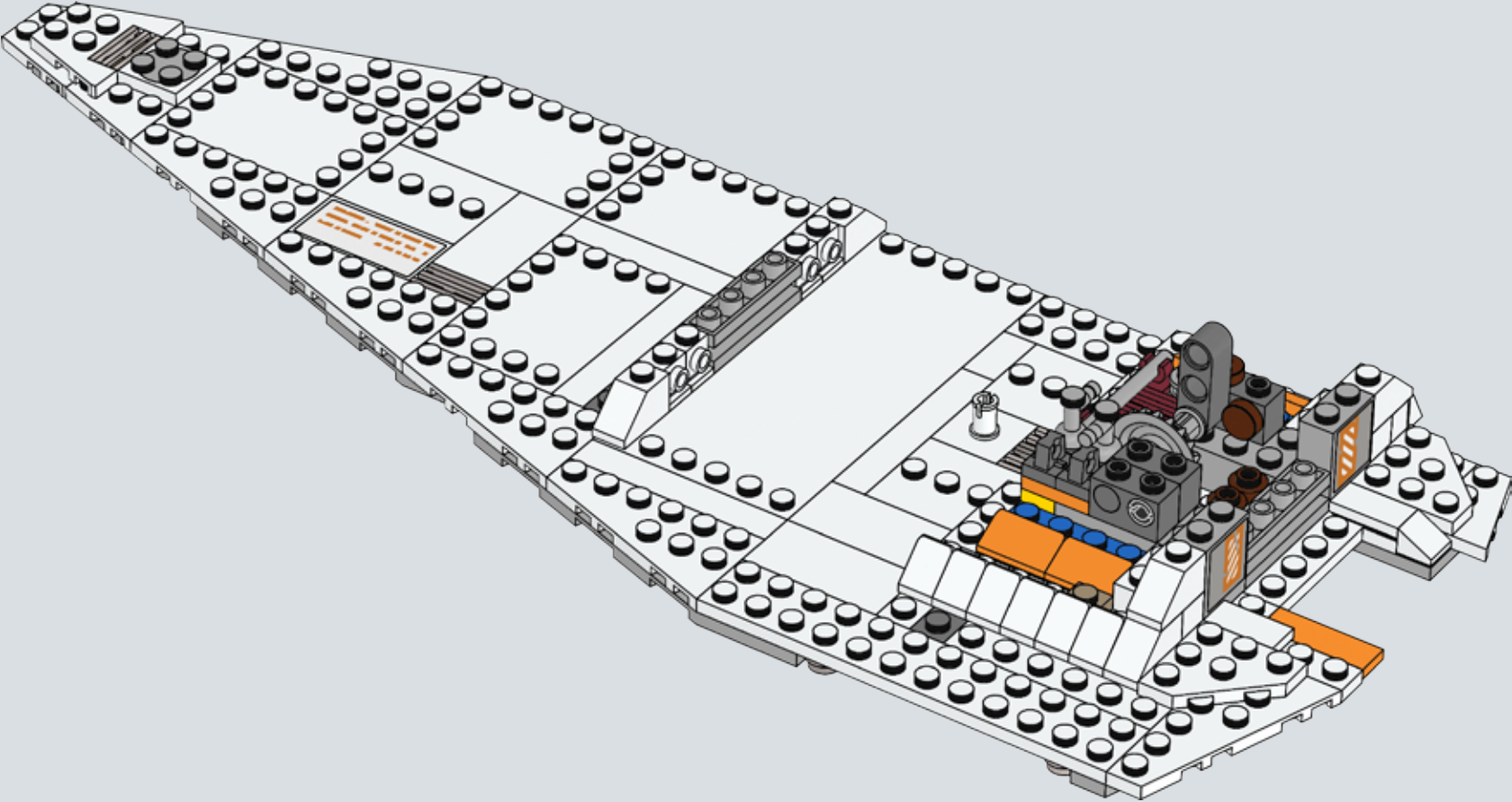

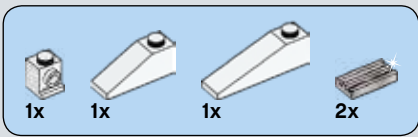

327

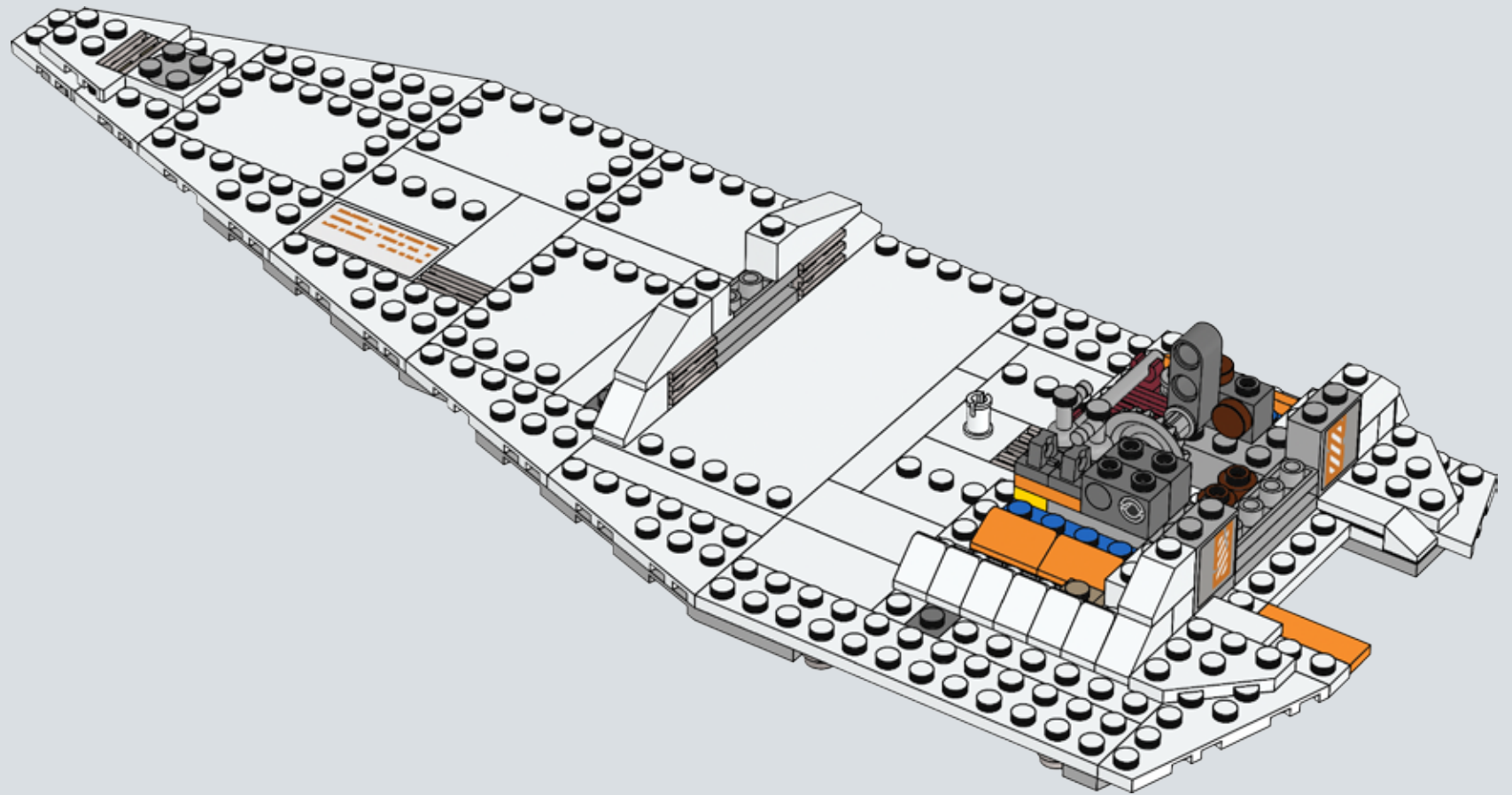



328

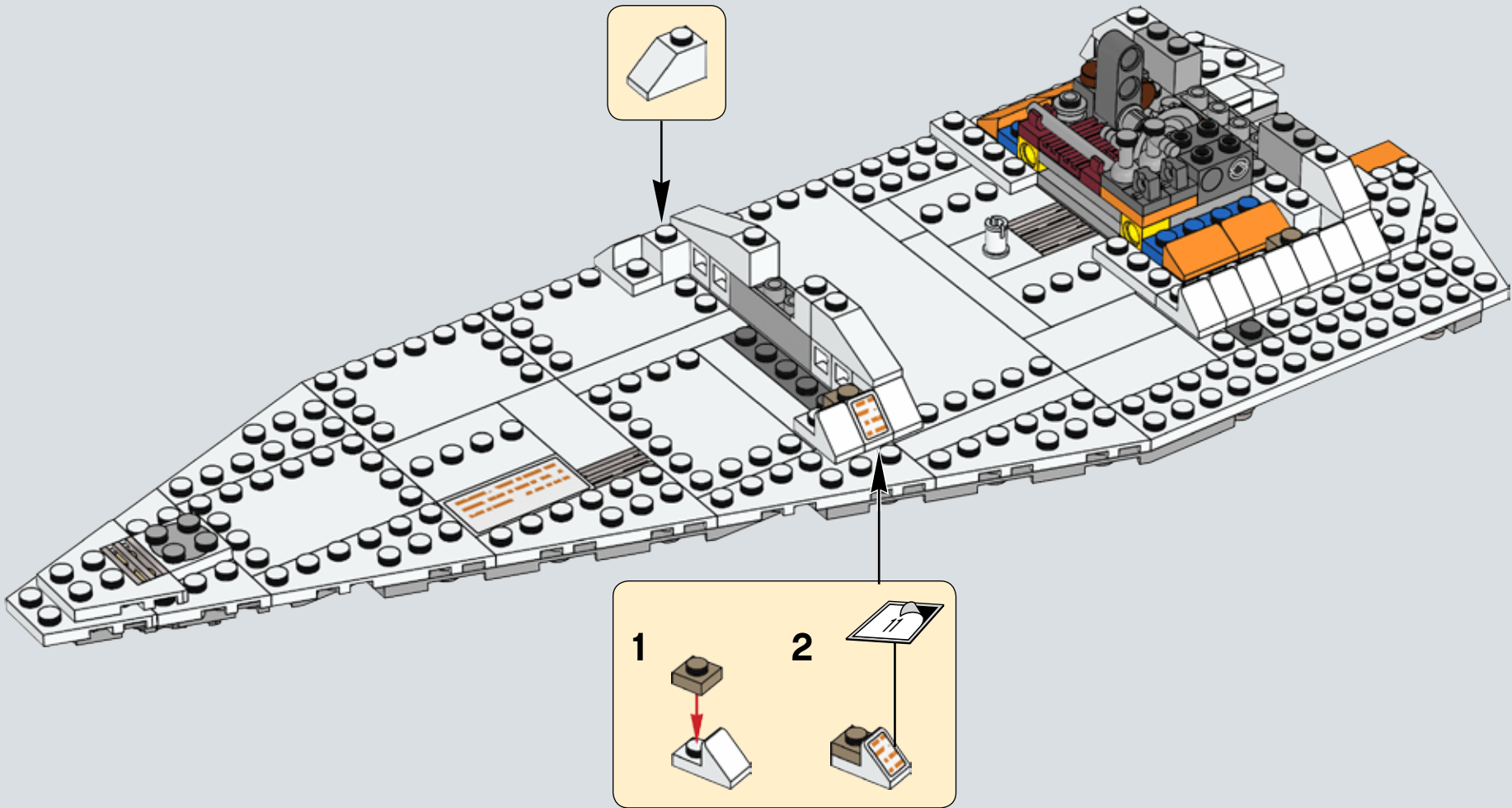

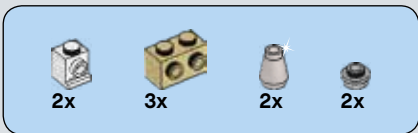

329

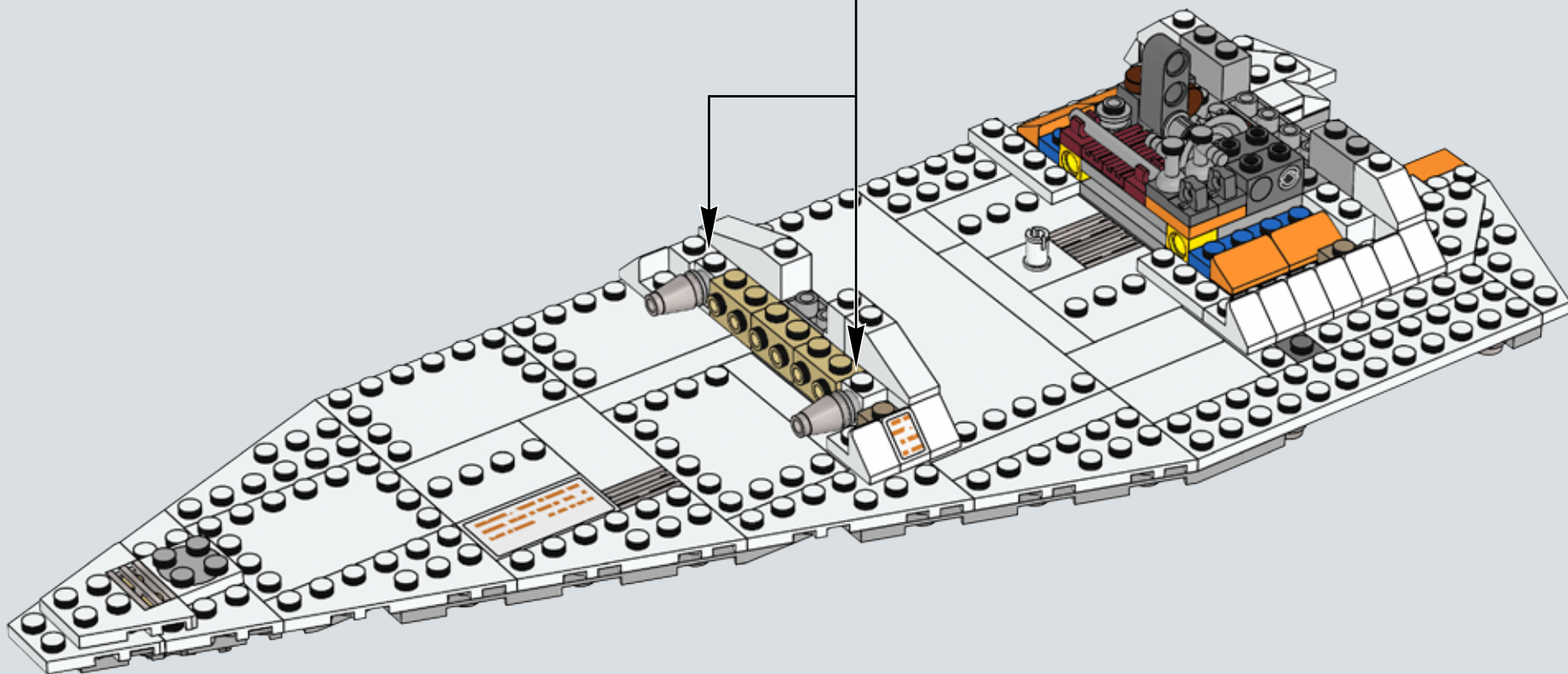
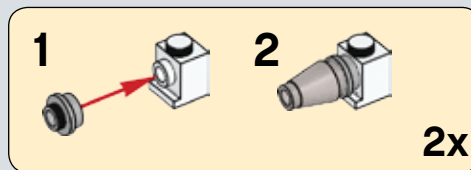



330

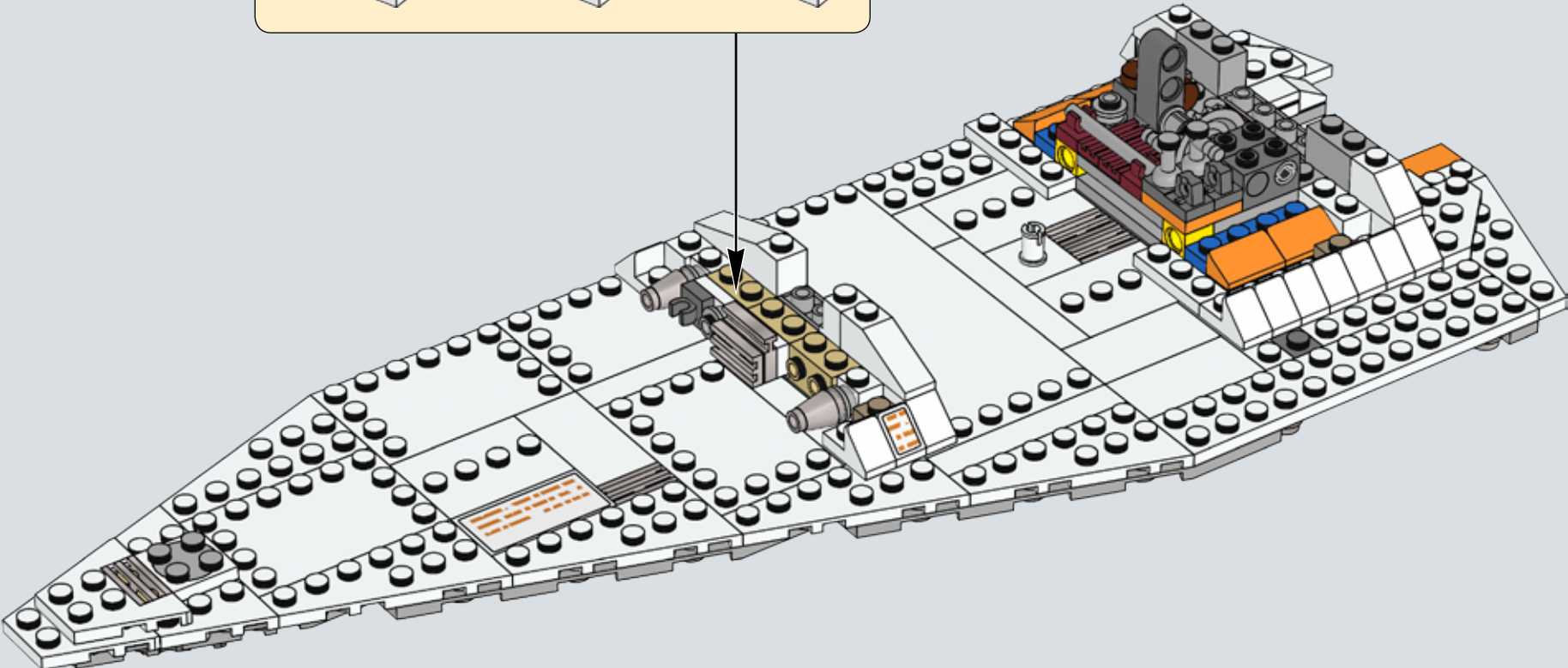



2x



1x

331

1

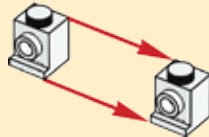

2

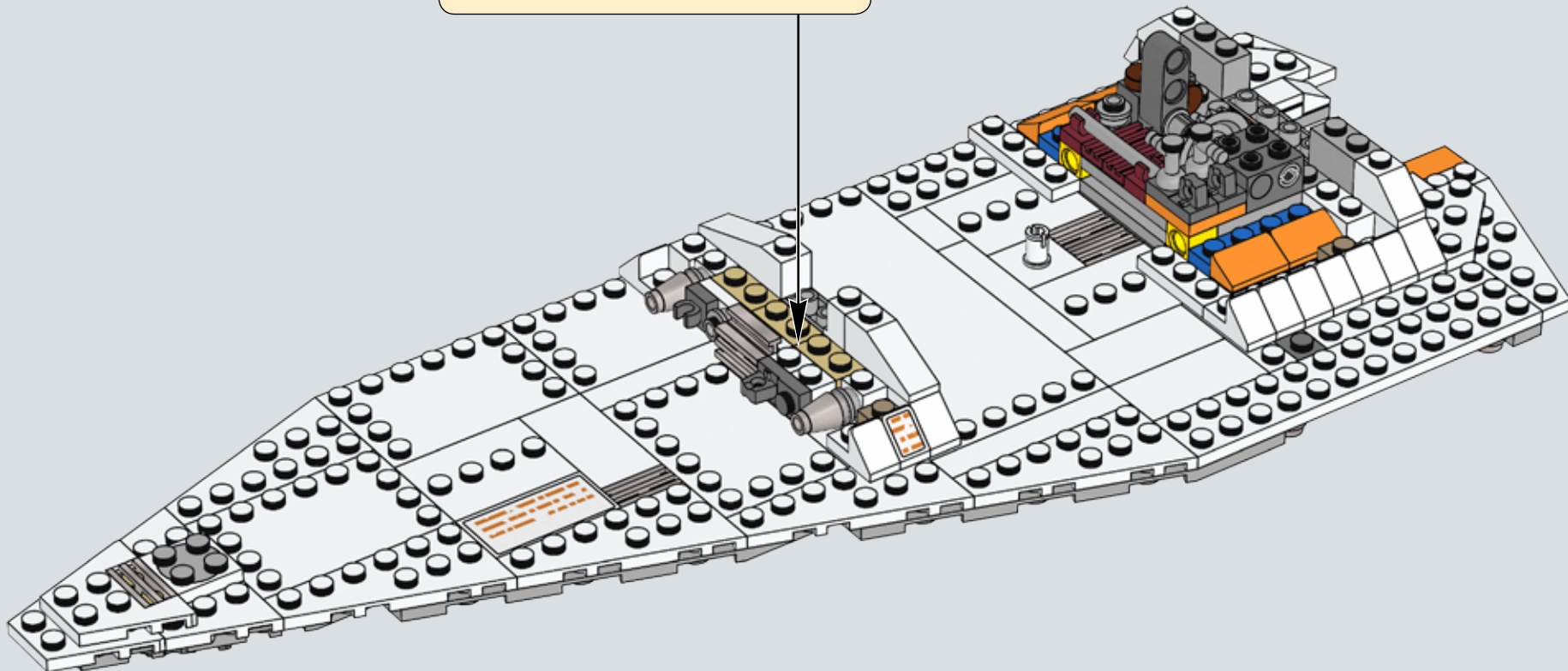



332

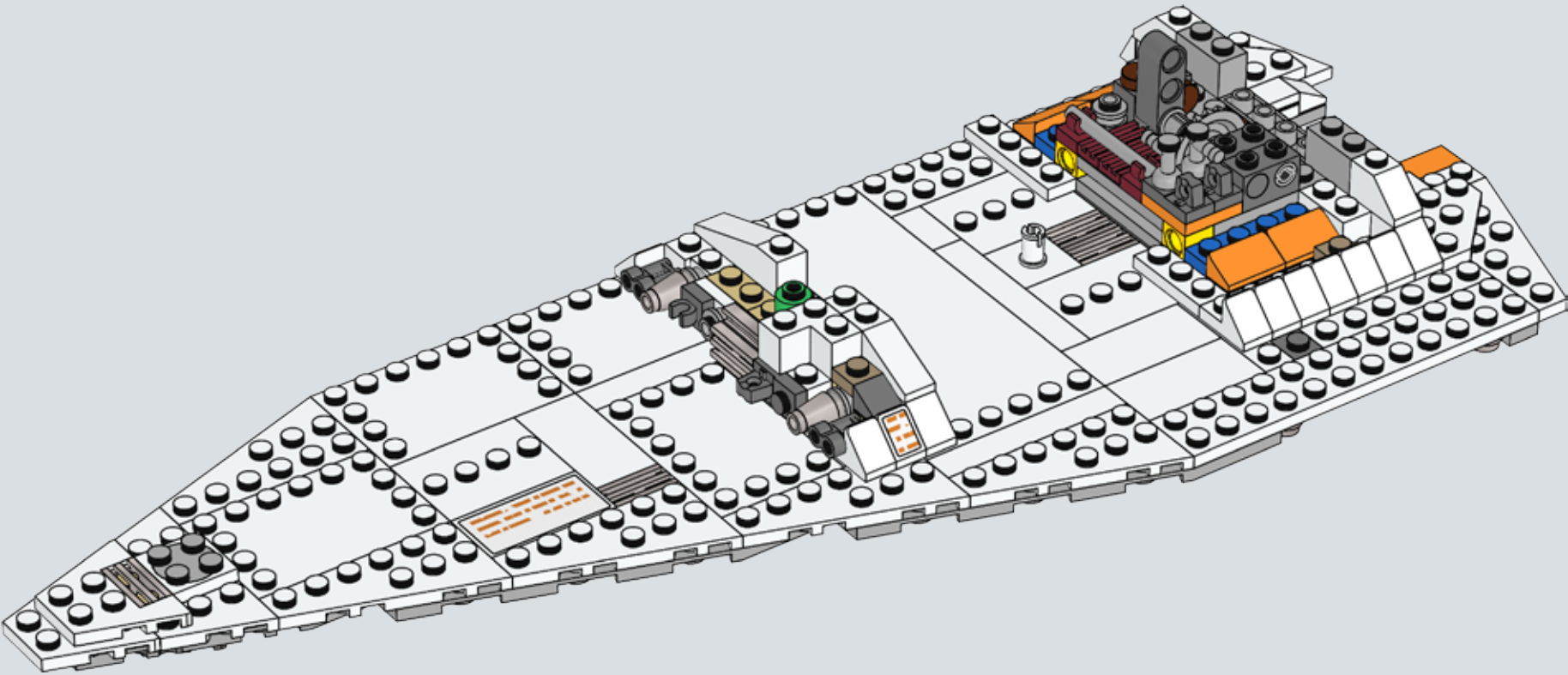

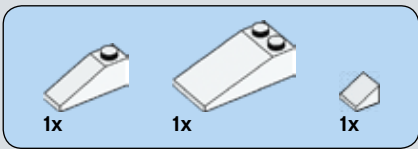

333

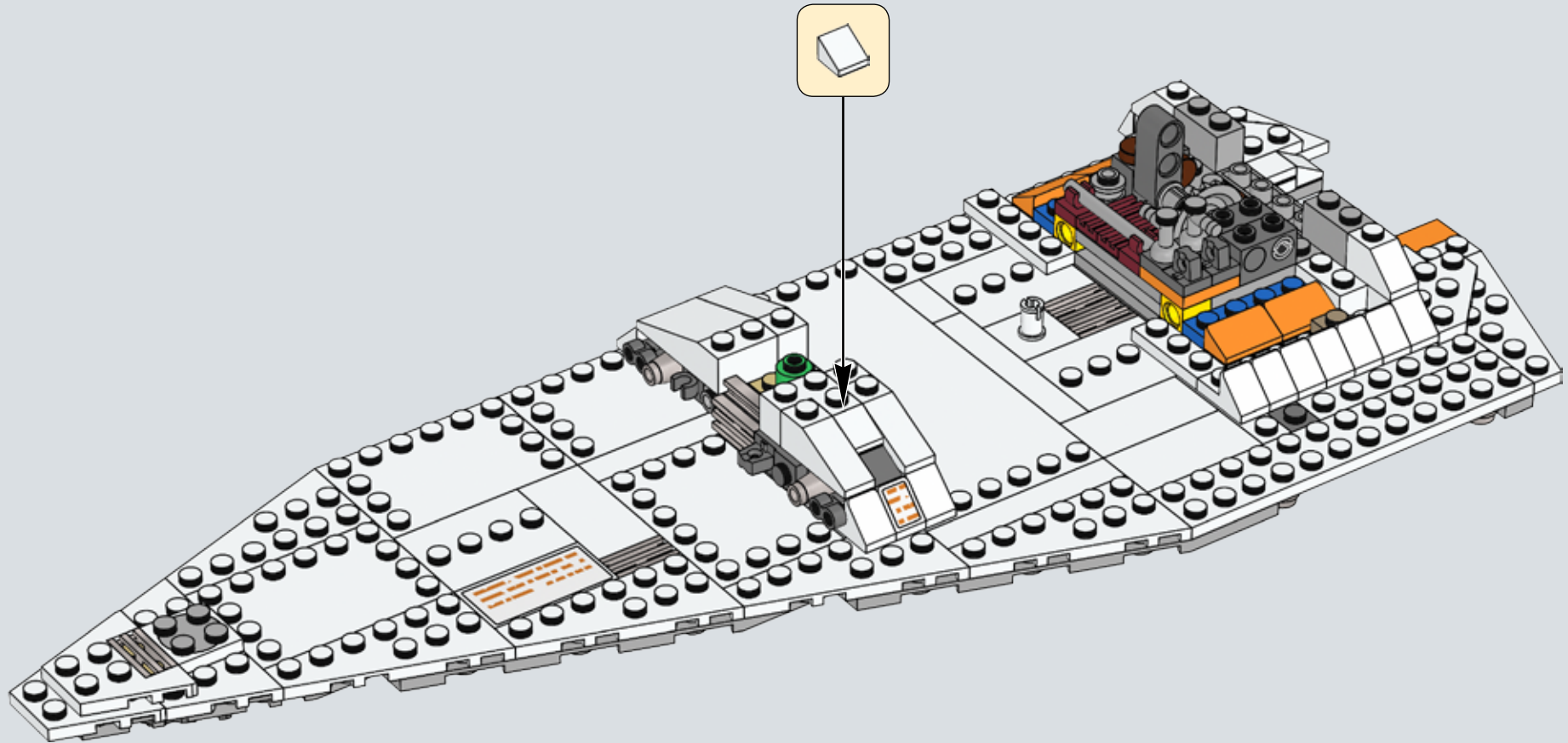

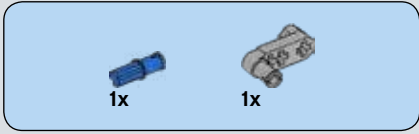
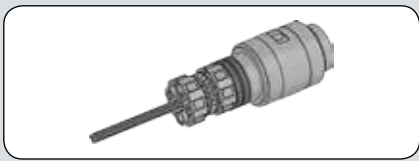

334

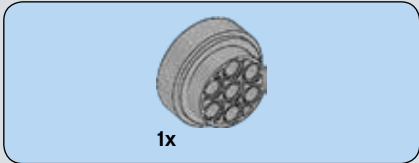
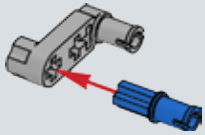

335

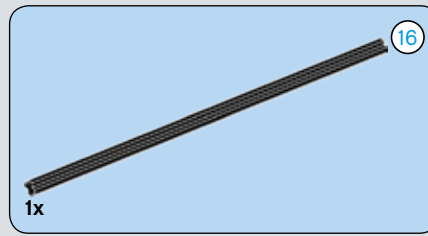
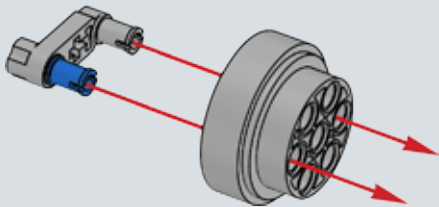

336

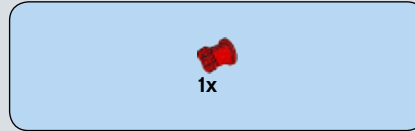

337

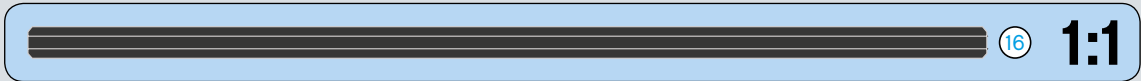
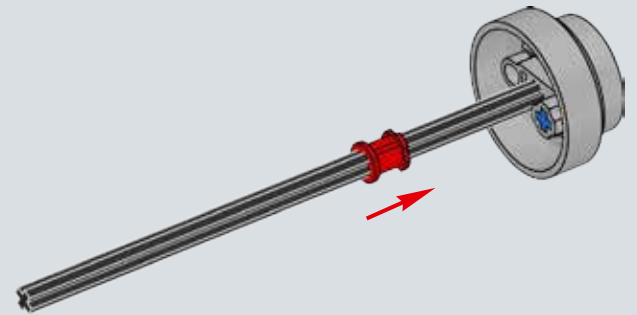

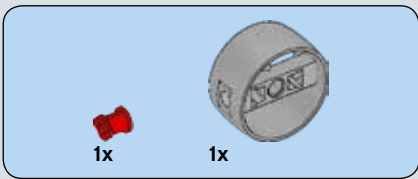

338

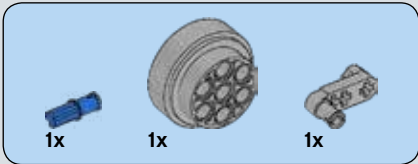
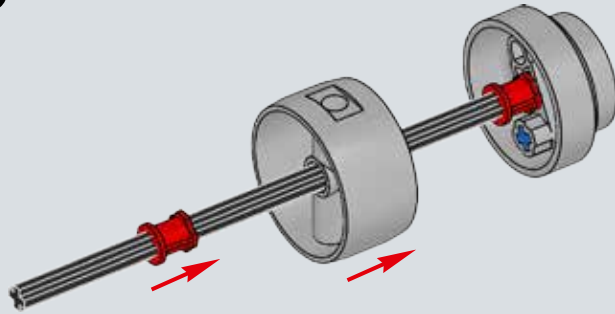

339

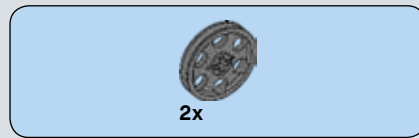
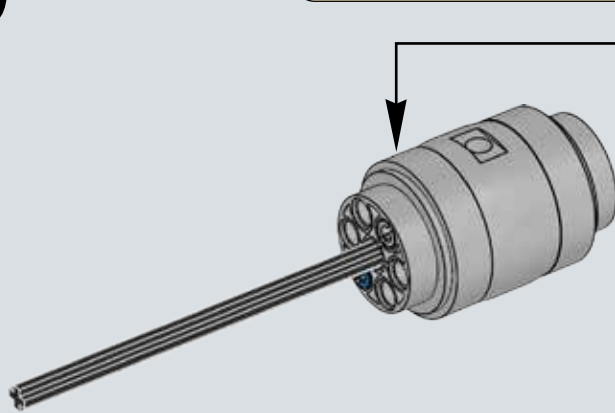
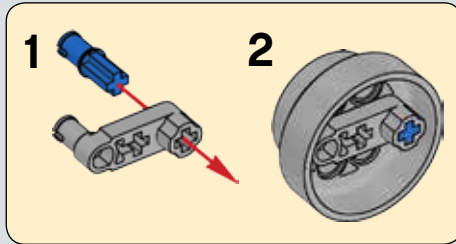

340

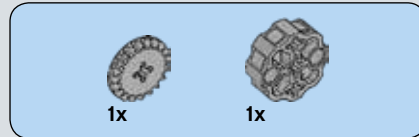
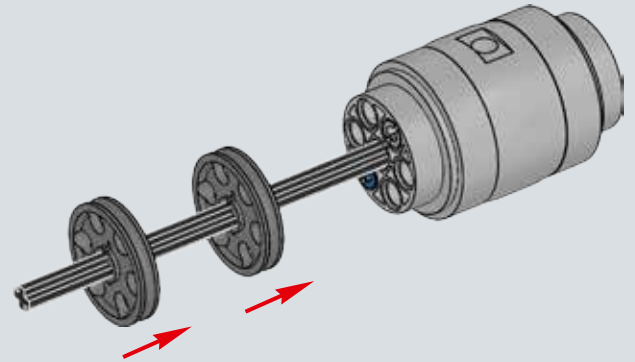

341

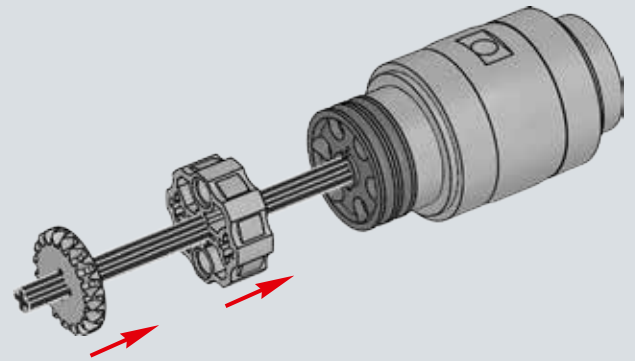

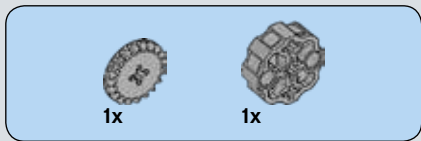

342

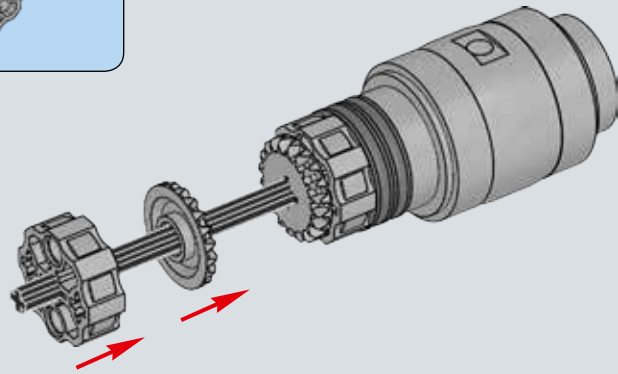

343

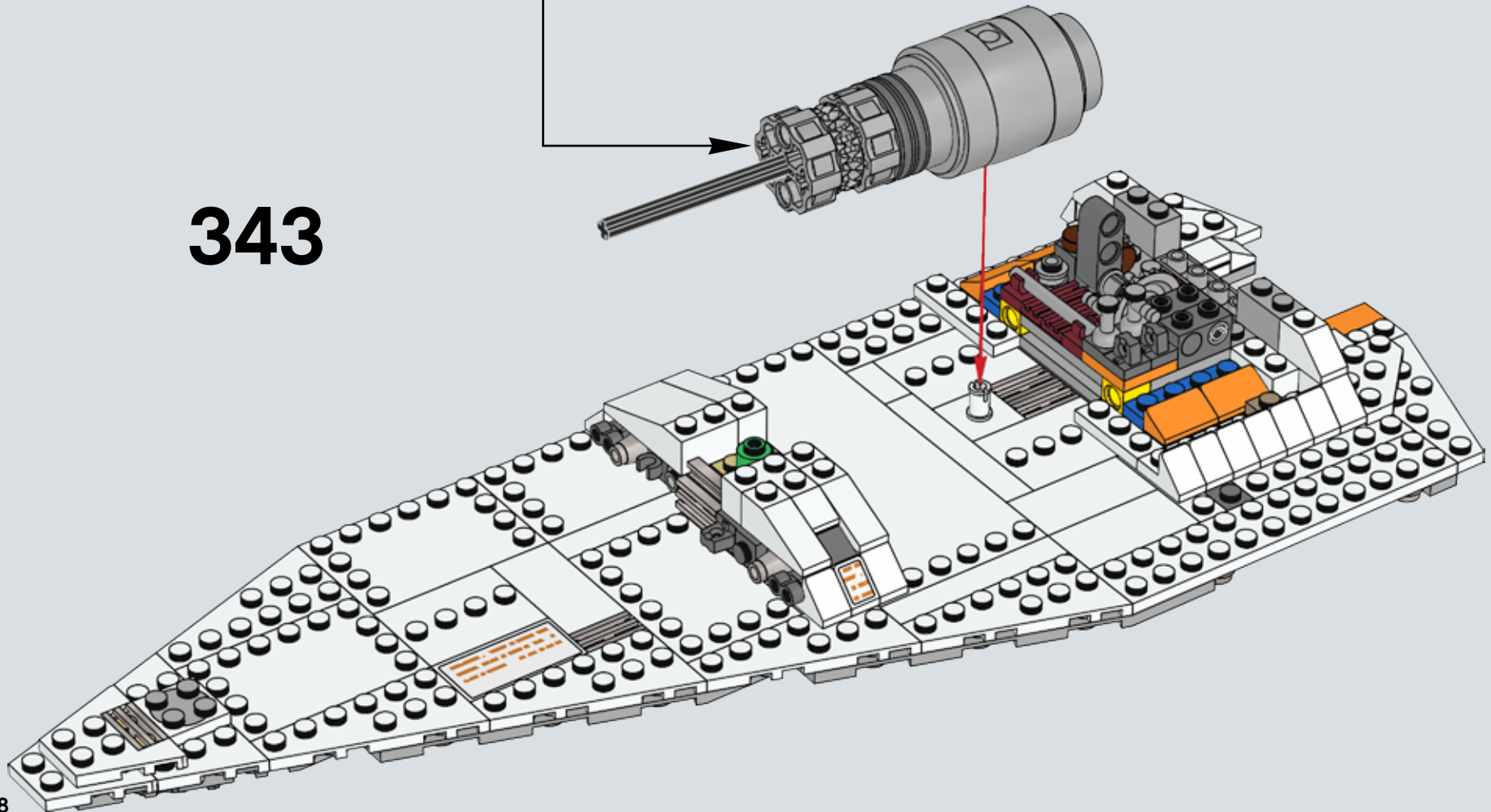

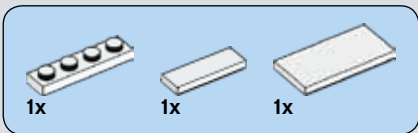

344

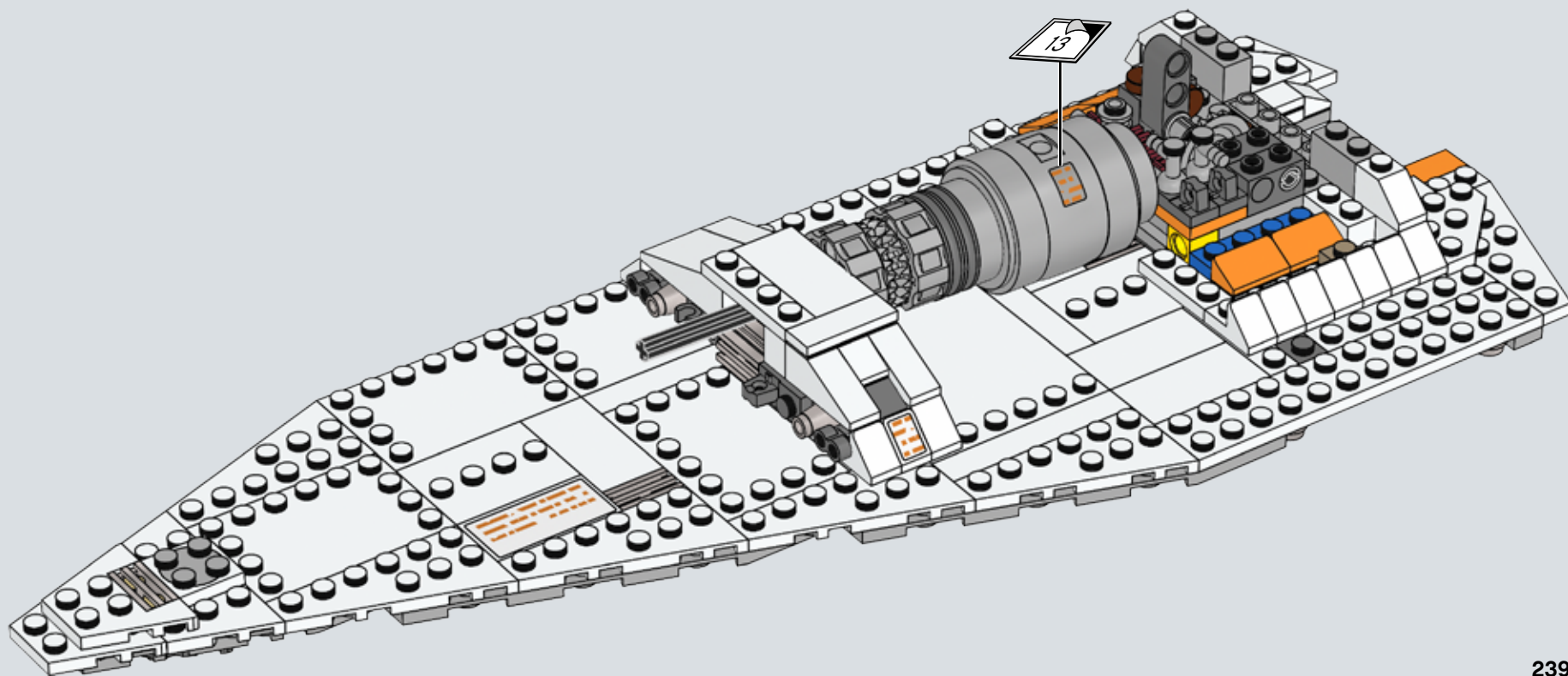



1x



1x

345

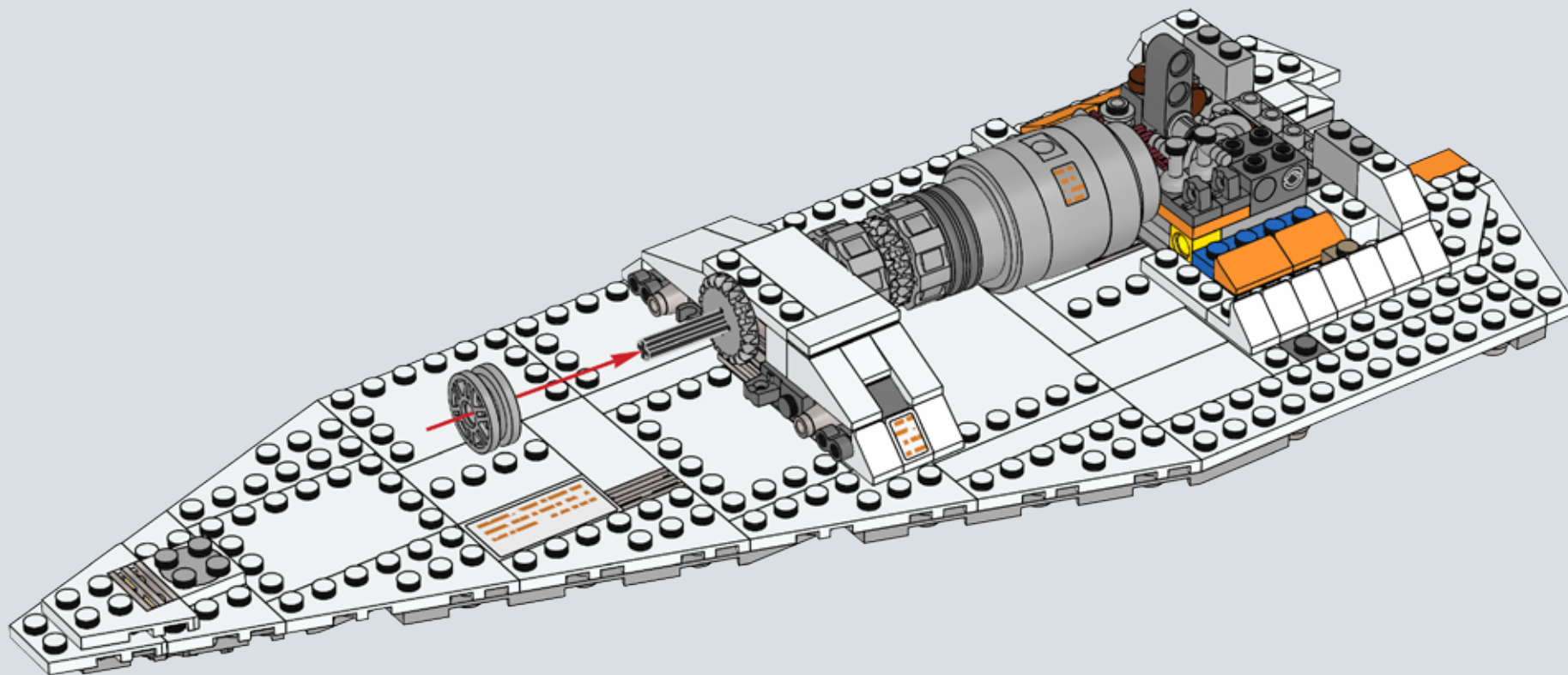



346

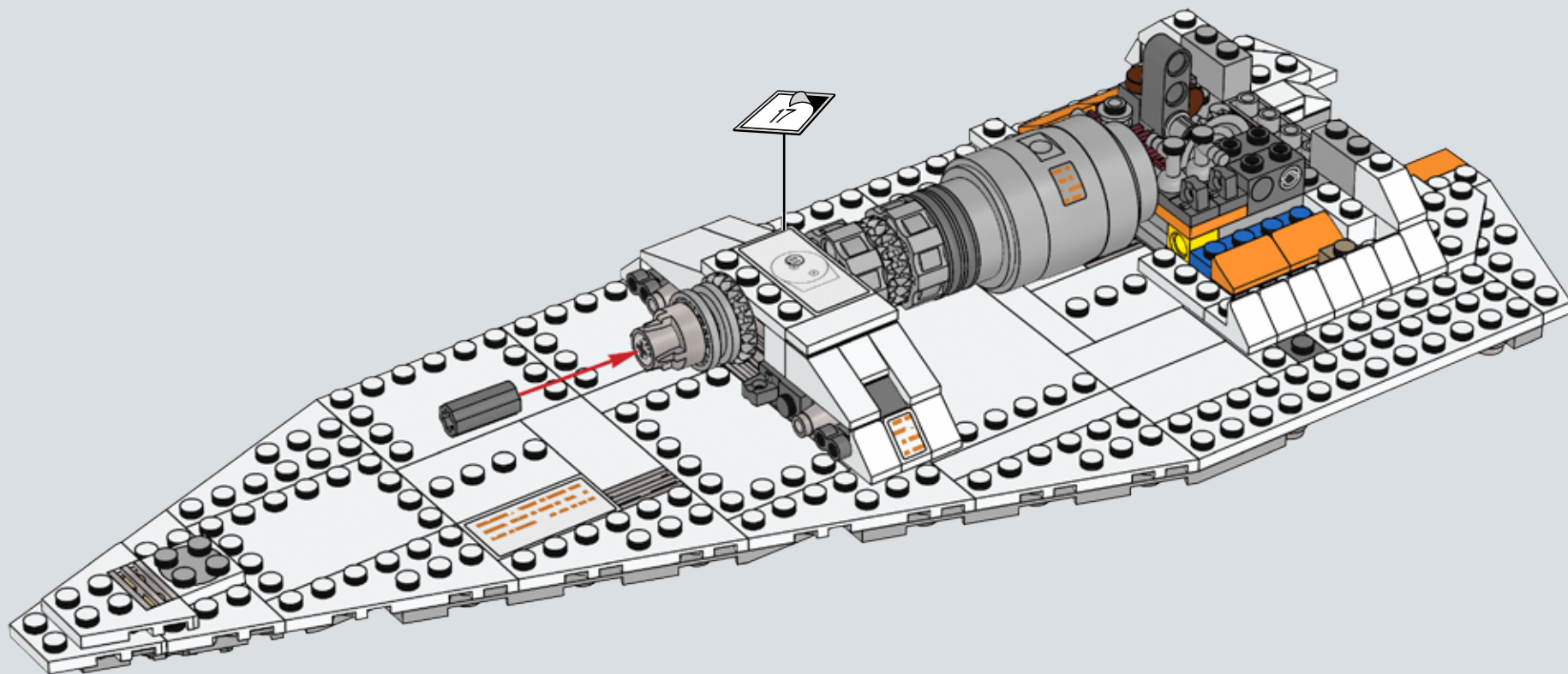

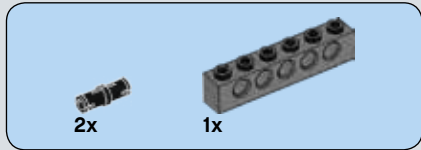

347

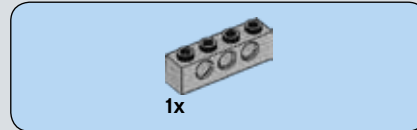
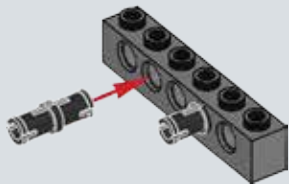

348

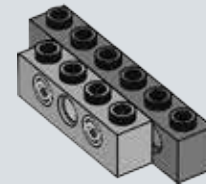

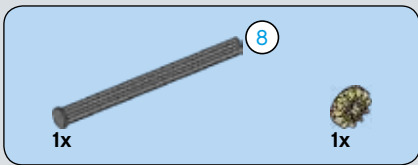

349

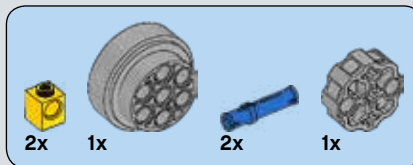
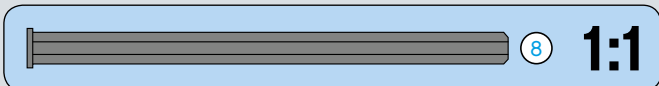
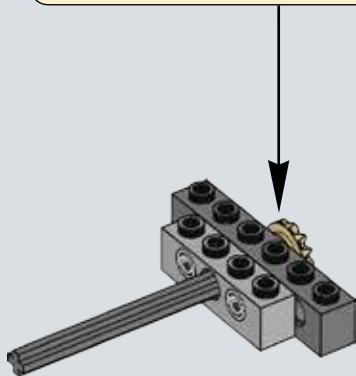
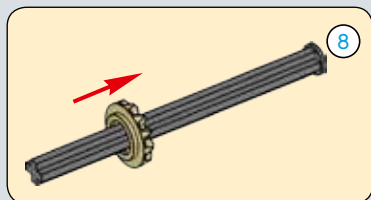

350

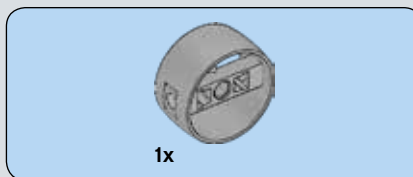
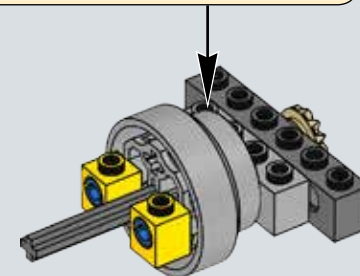
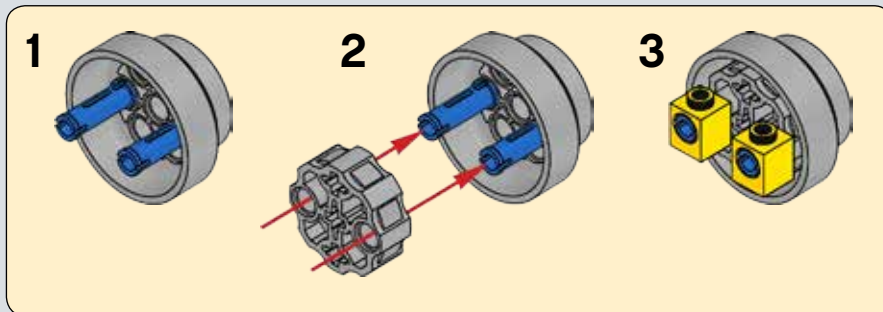

351

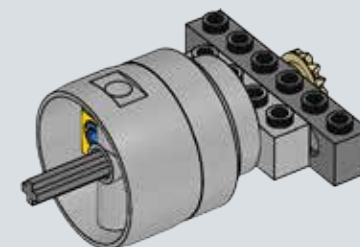

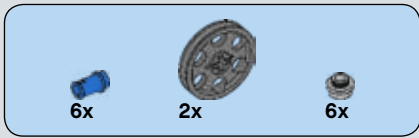

352

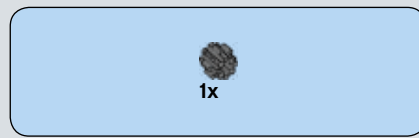
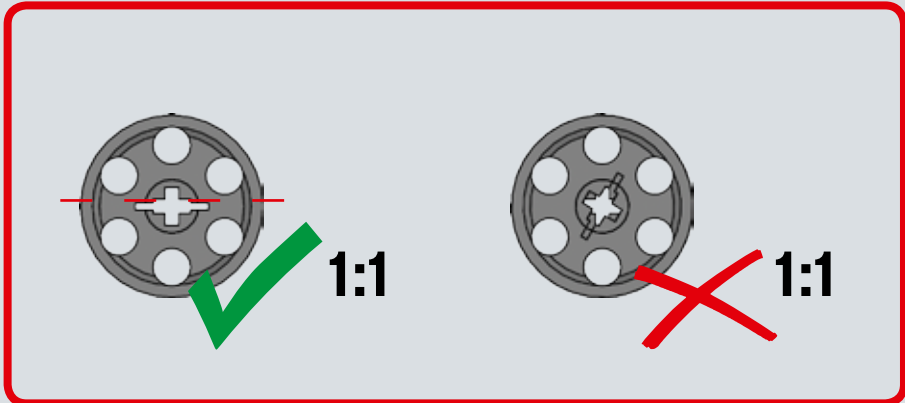
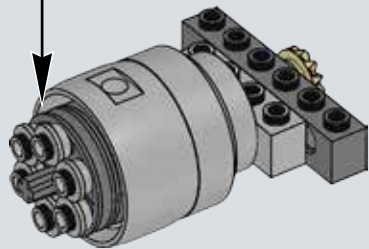
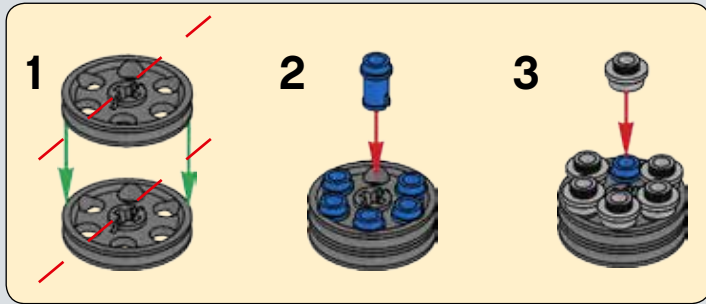

353

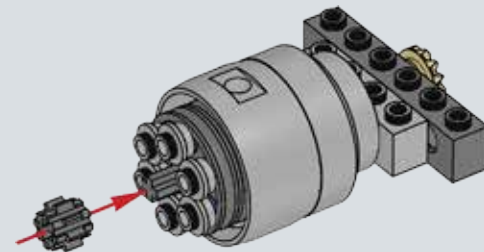

354

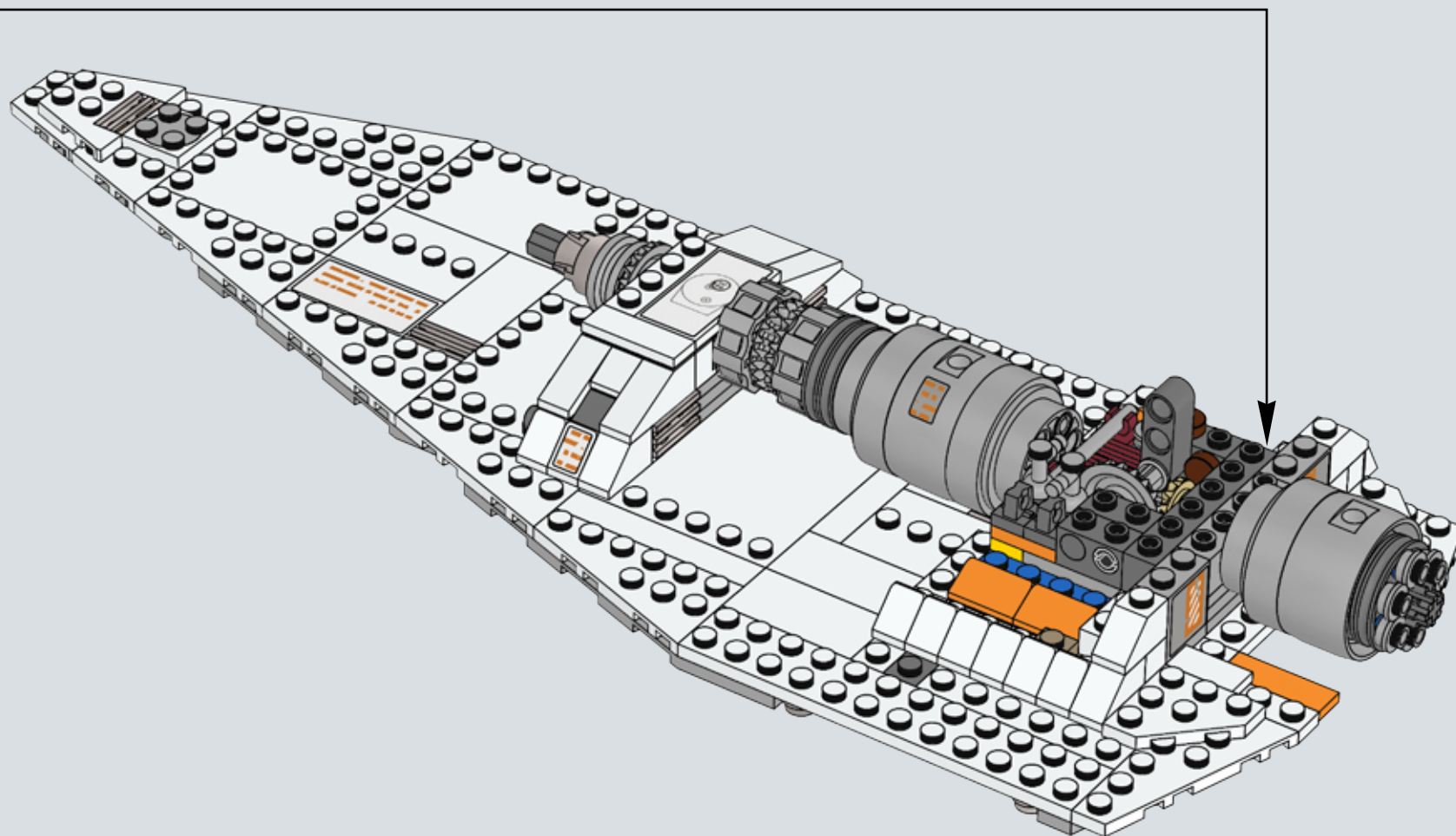



355

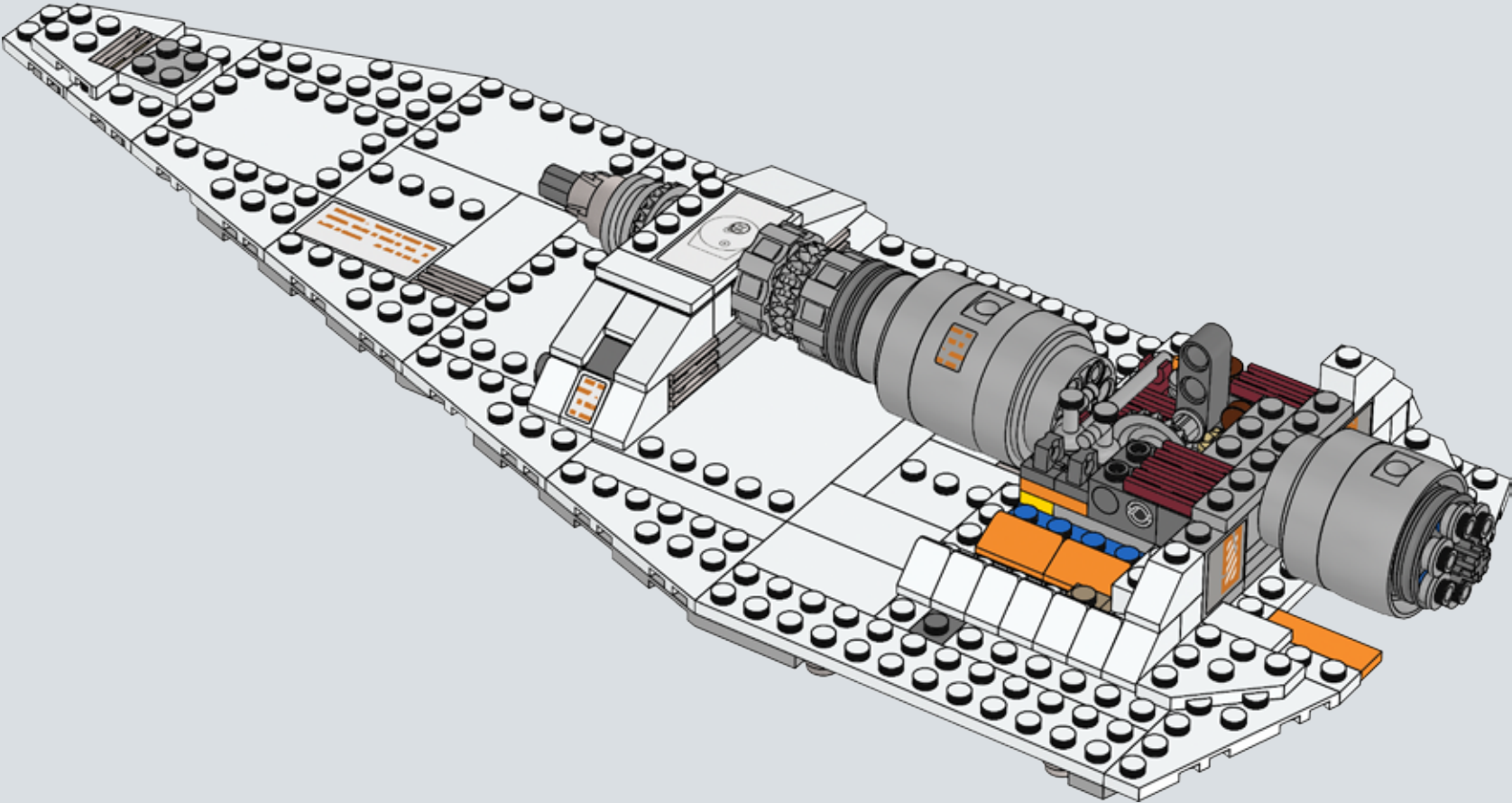



356

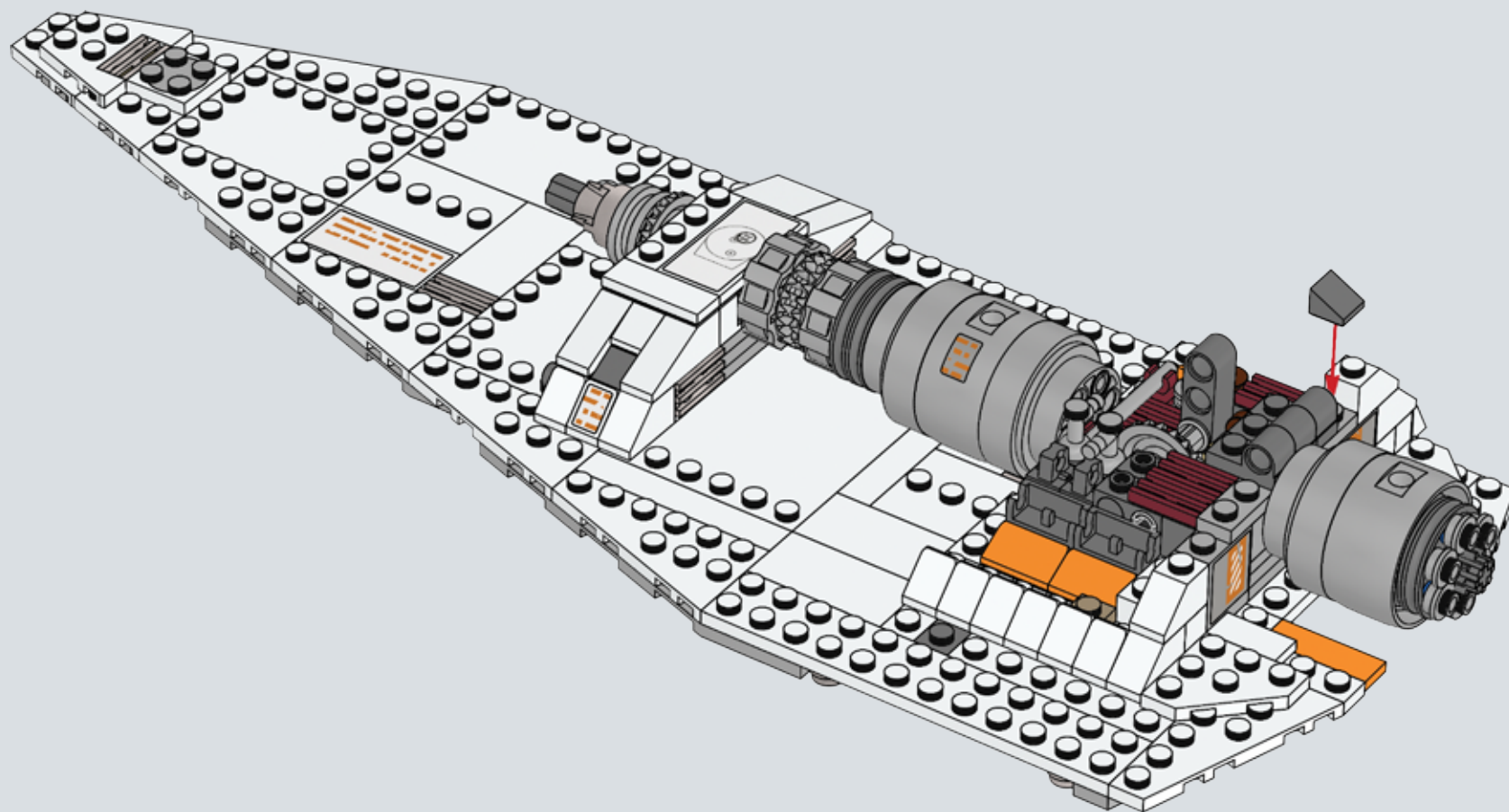



357

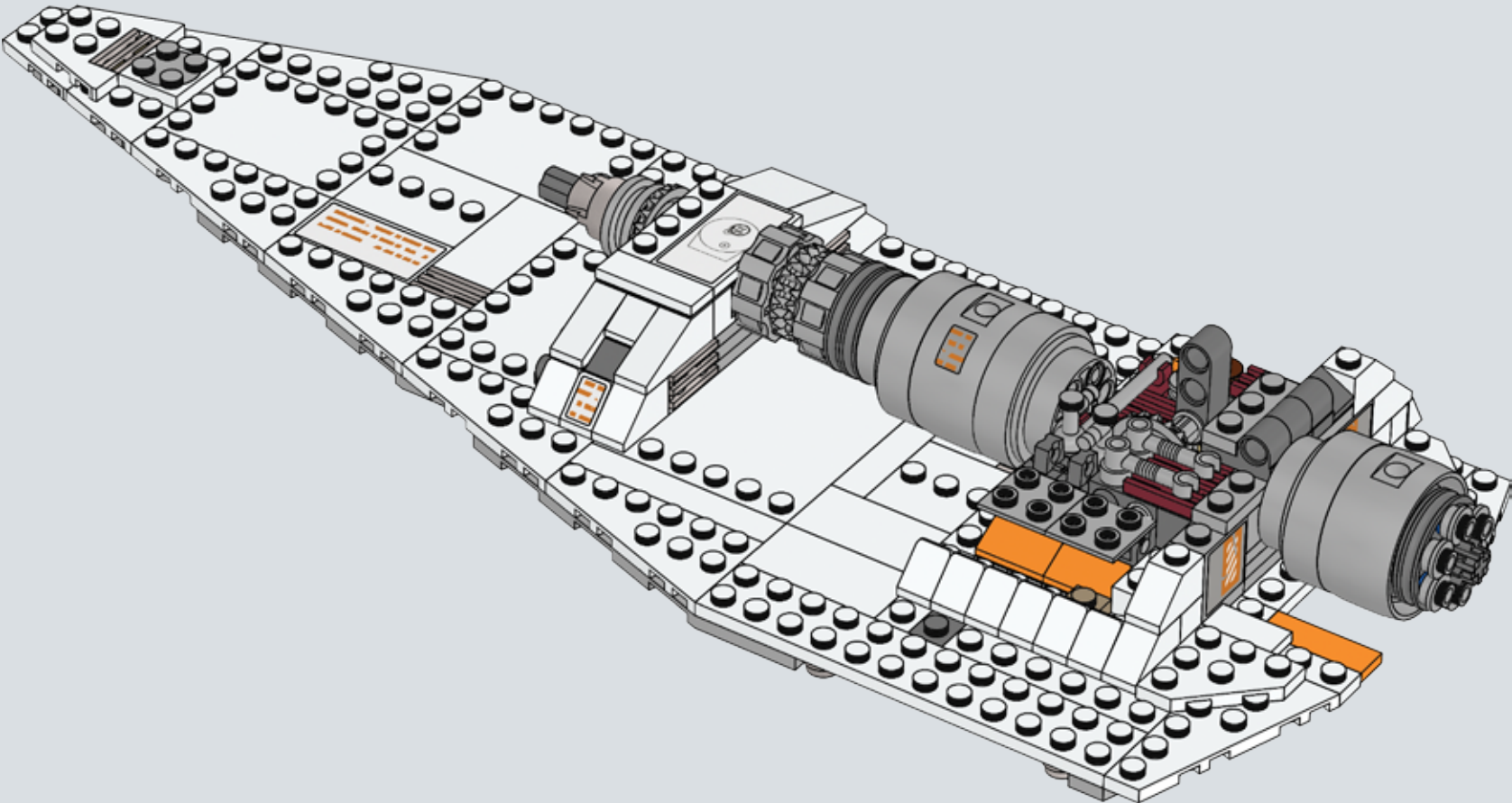



358

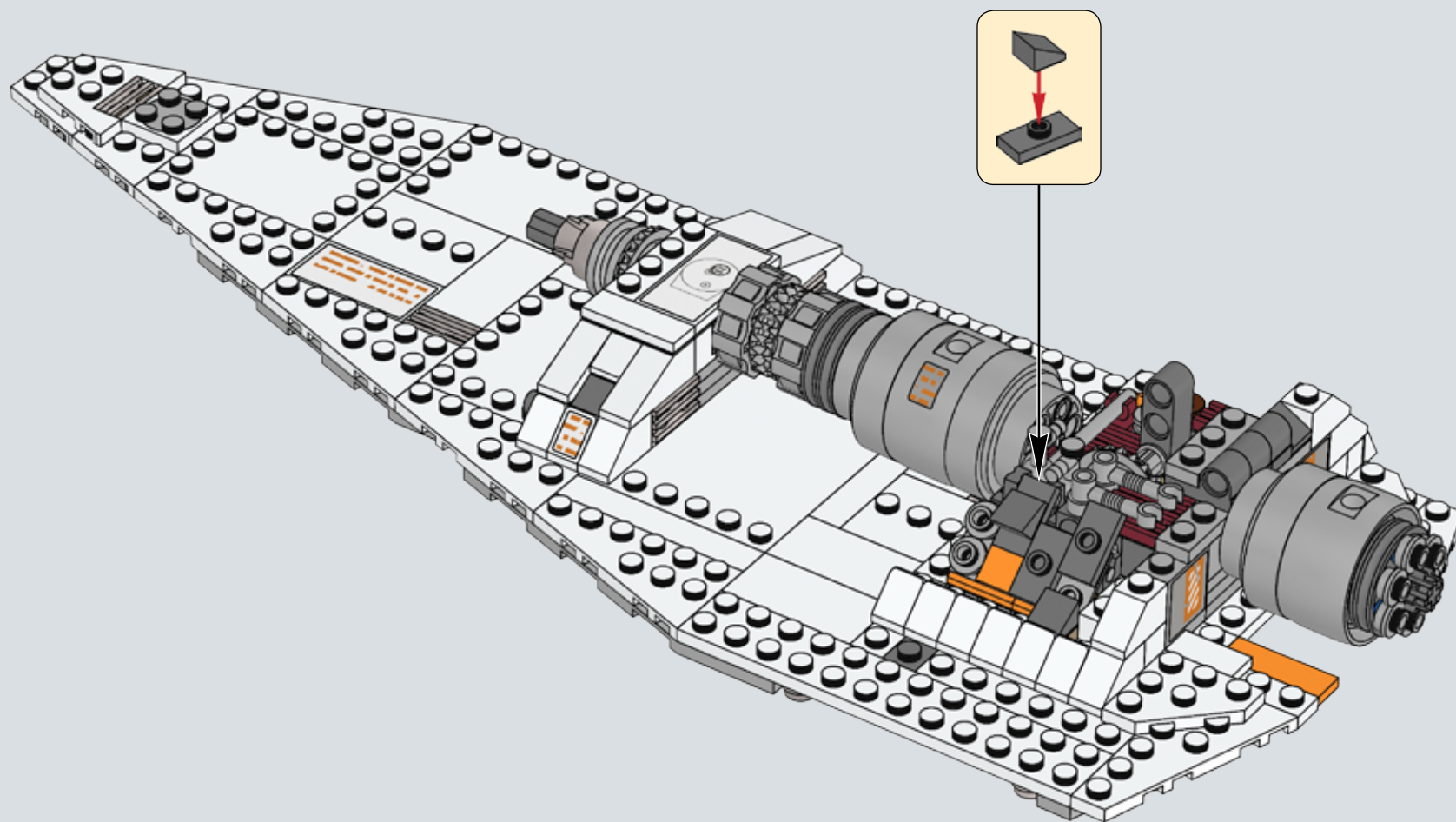



359

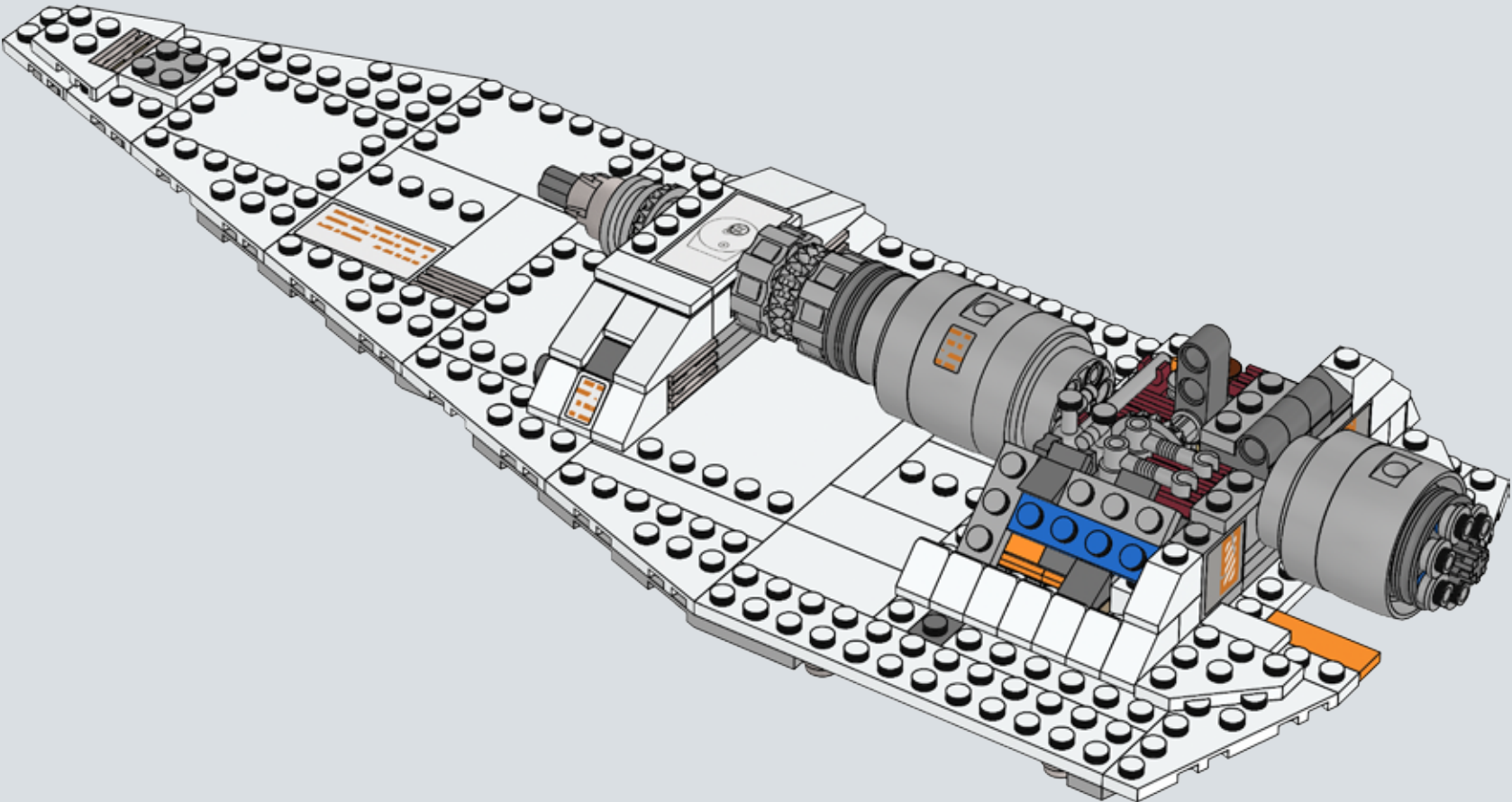

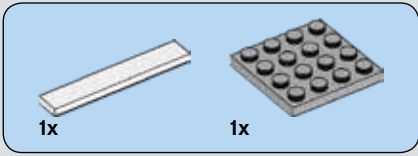

360

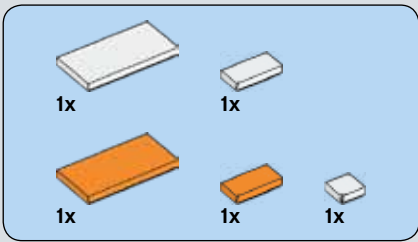
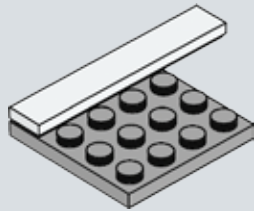

361

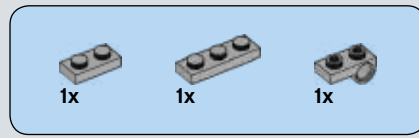
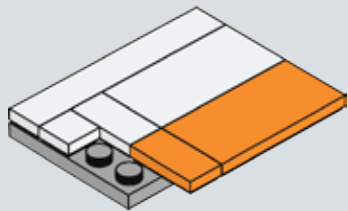

362

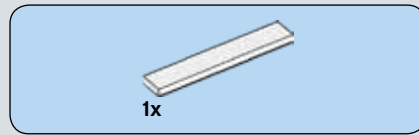
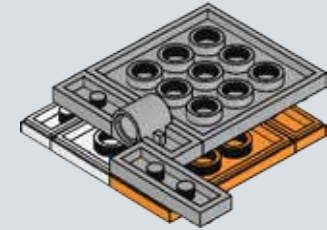
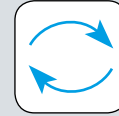

363

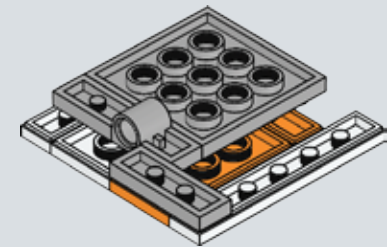



2x

364

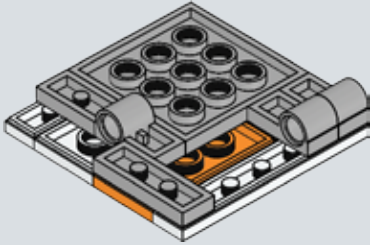

1x



1x

365

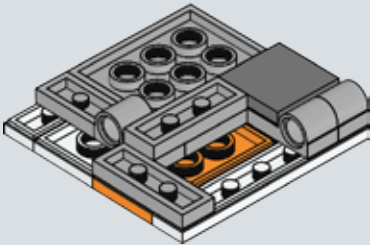

1x

366

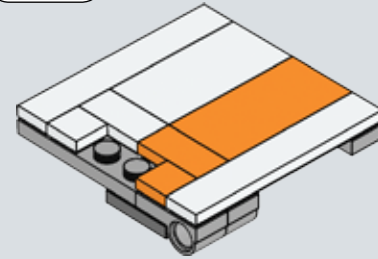
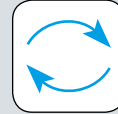

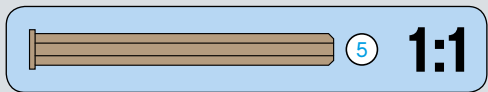
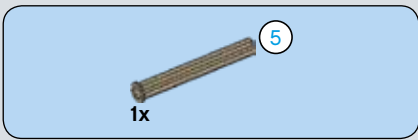

367

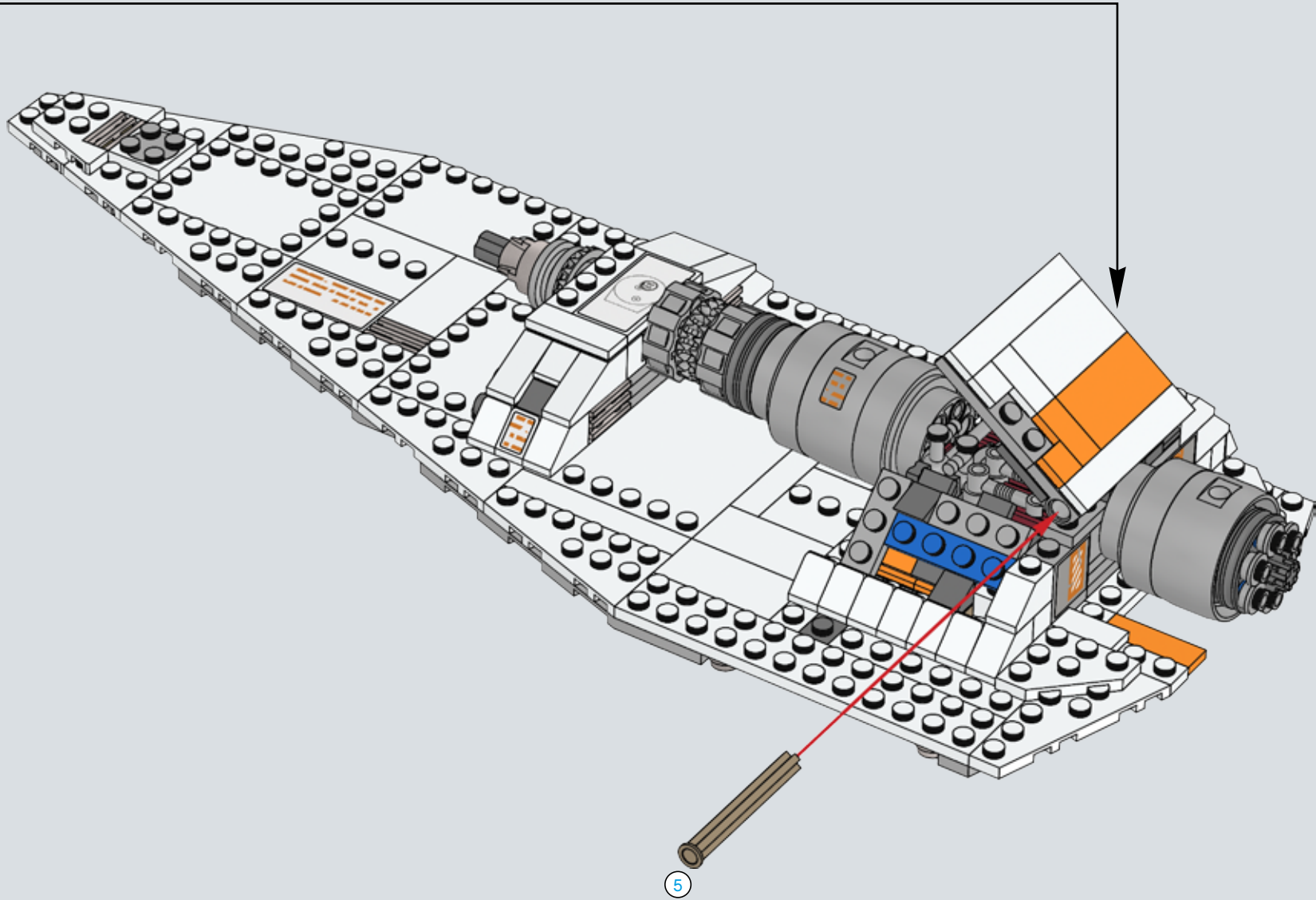



1x

368

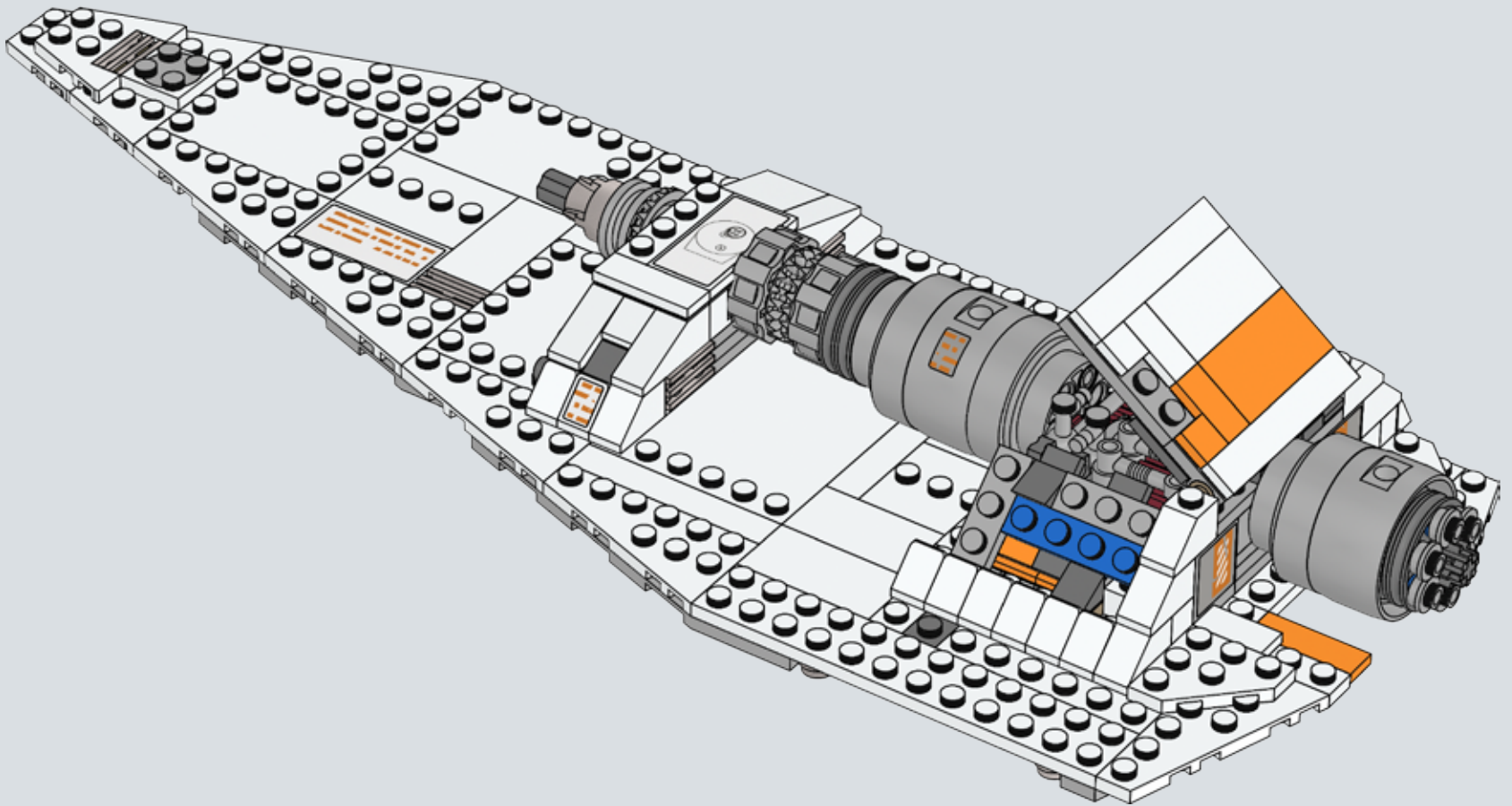

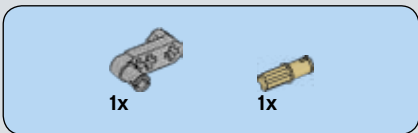

369

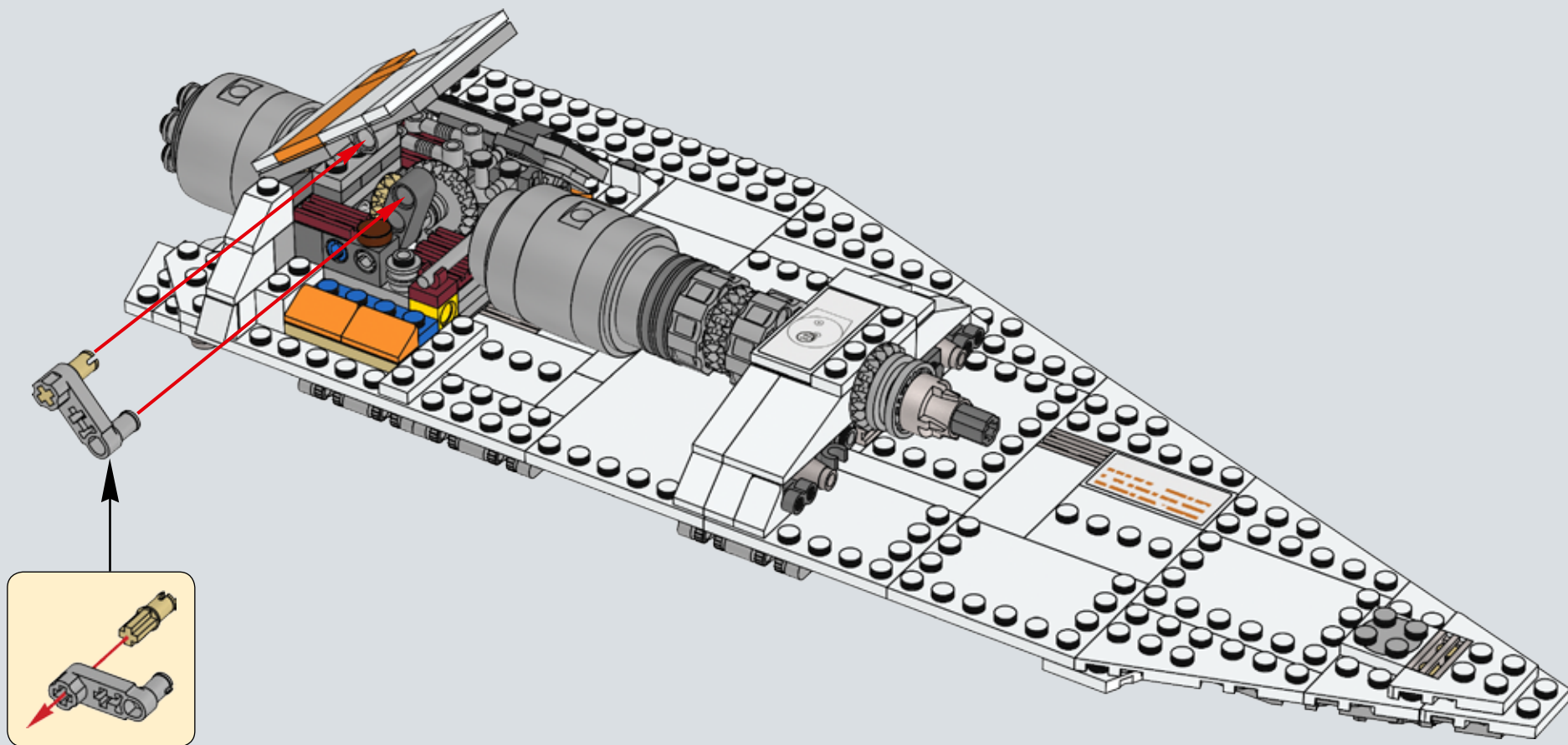
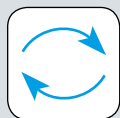

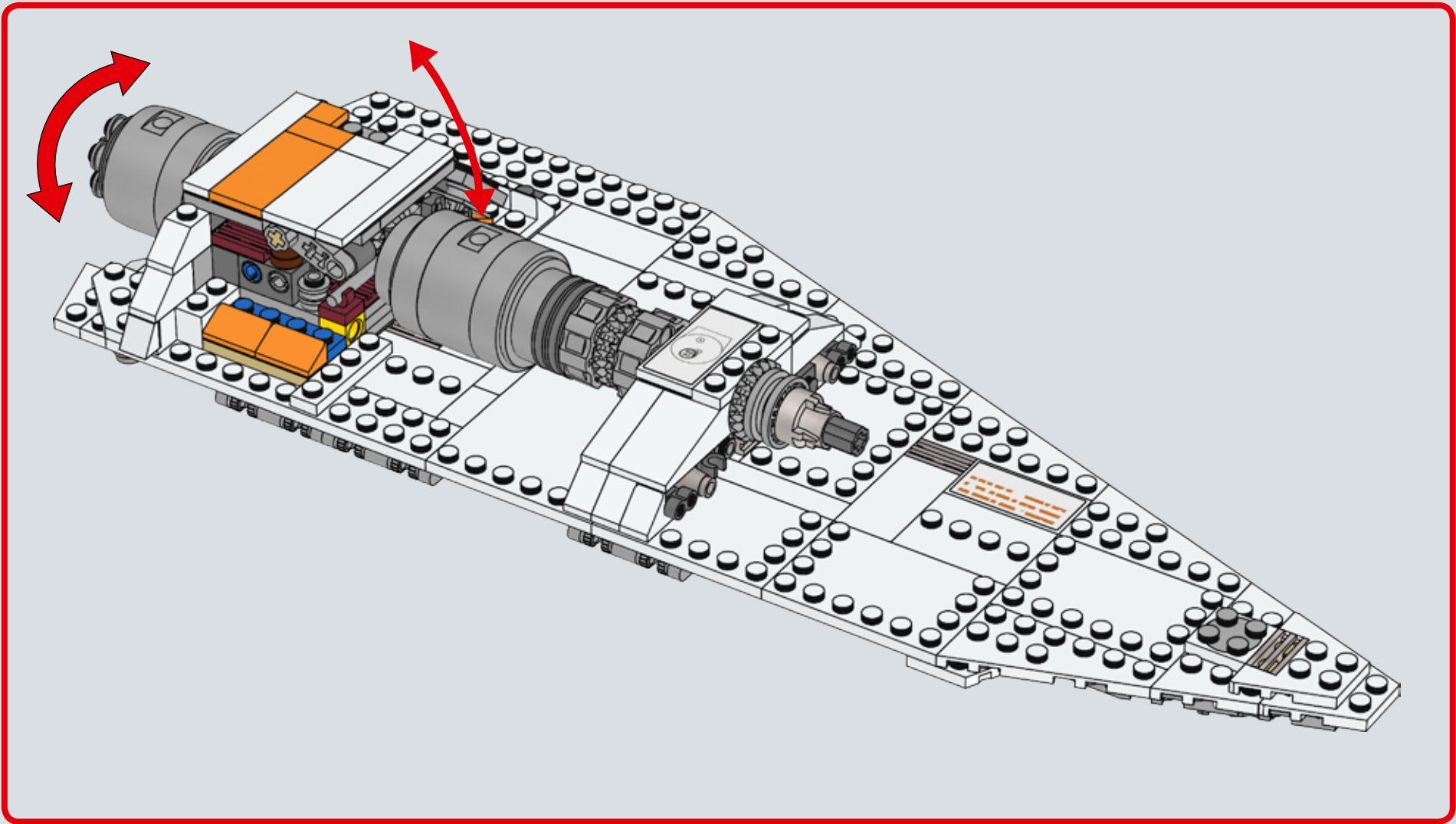



370

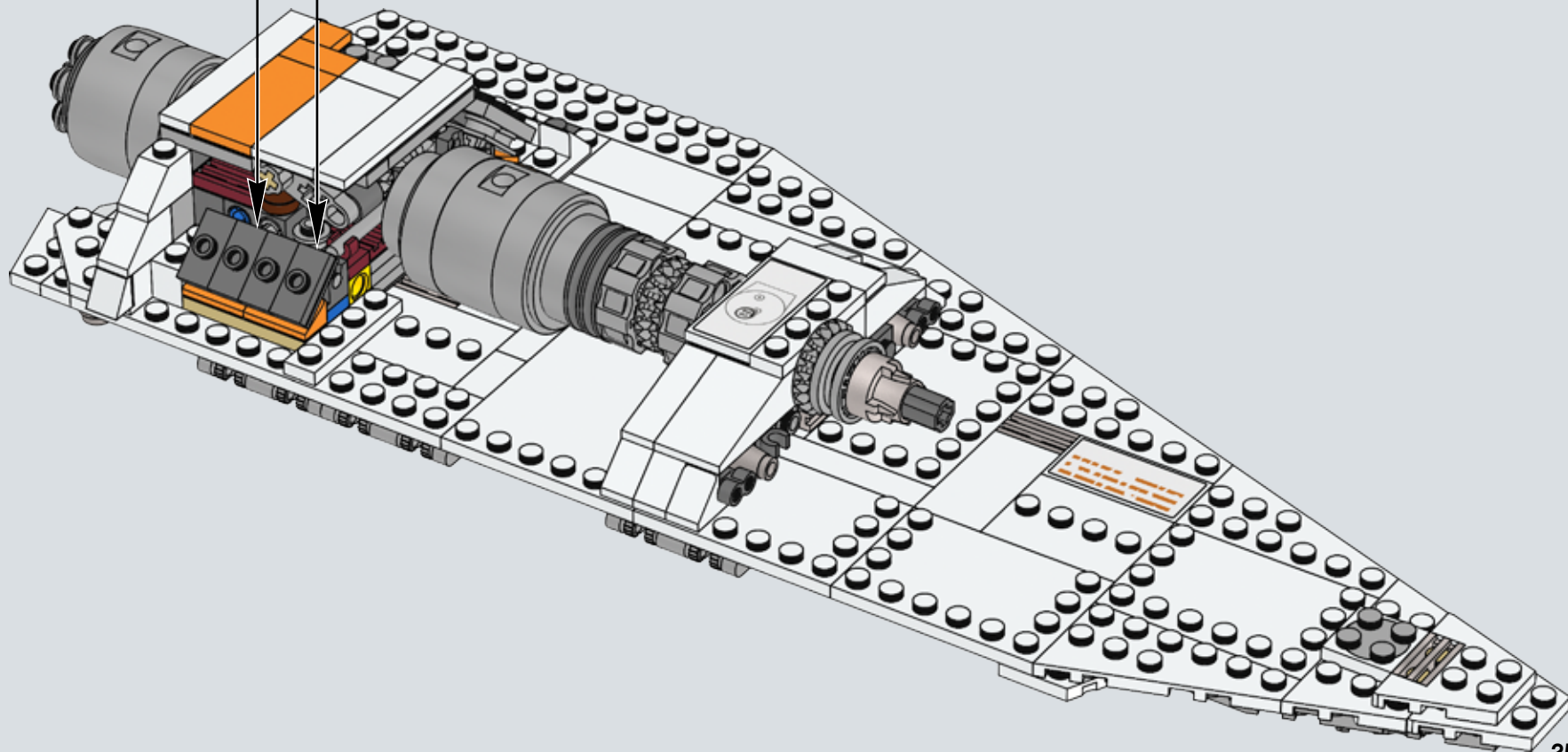
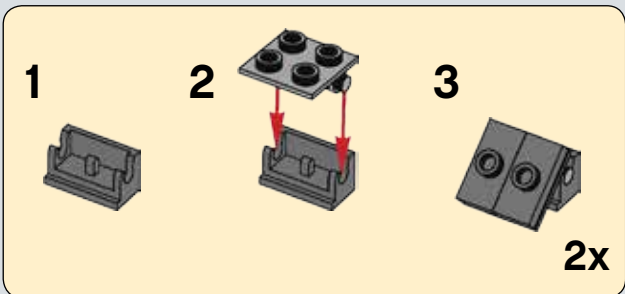

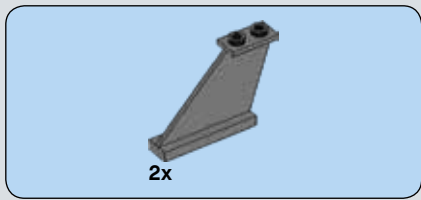

371

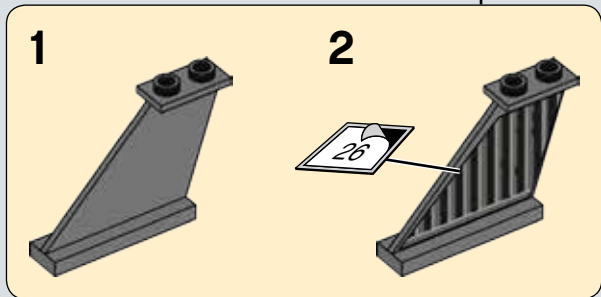
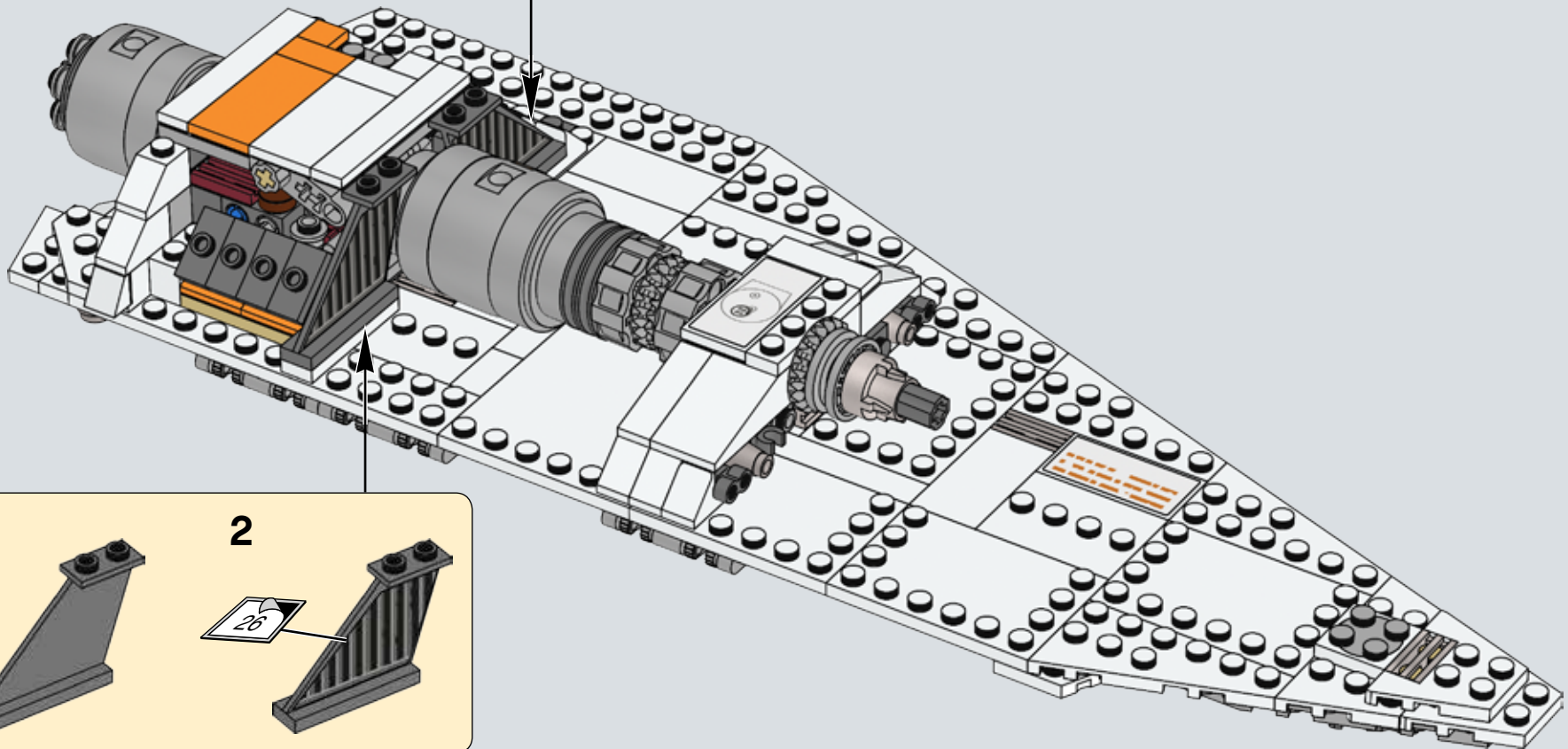
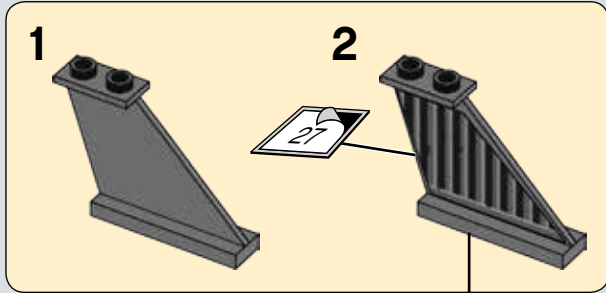



372

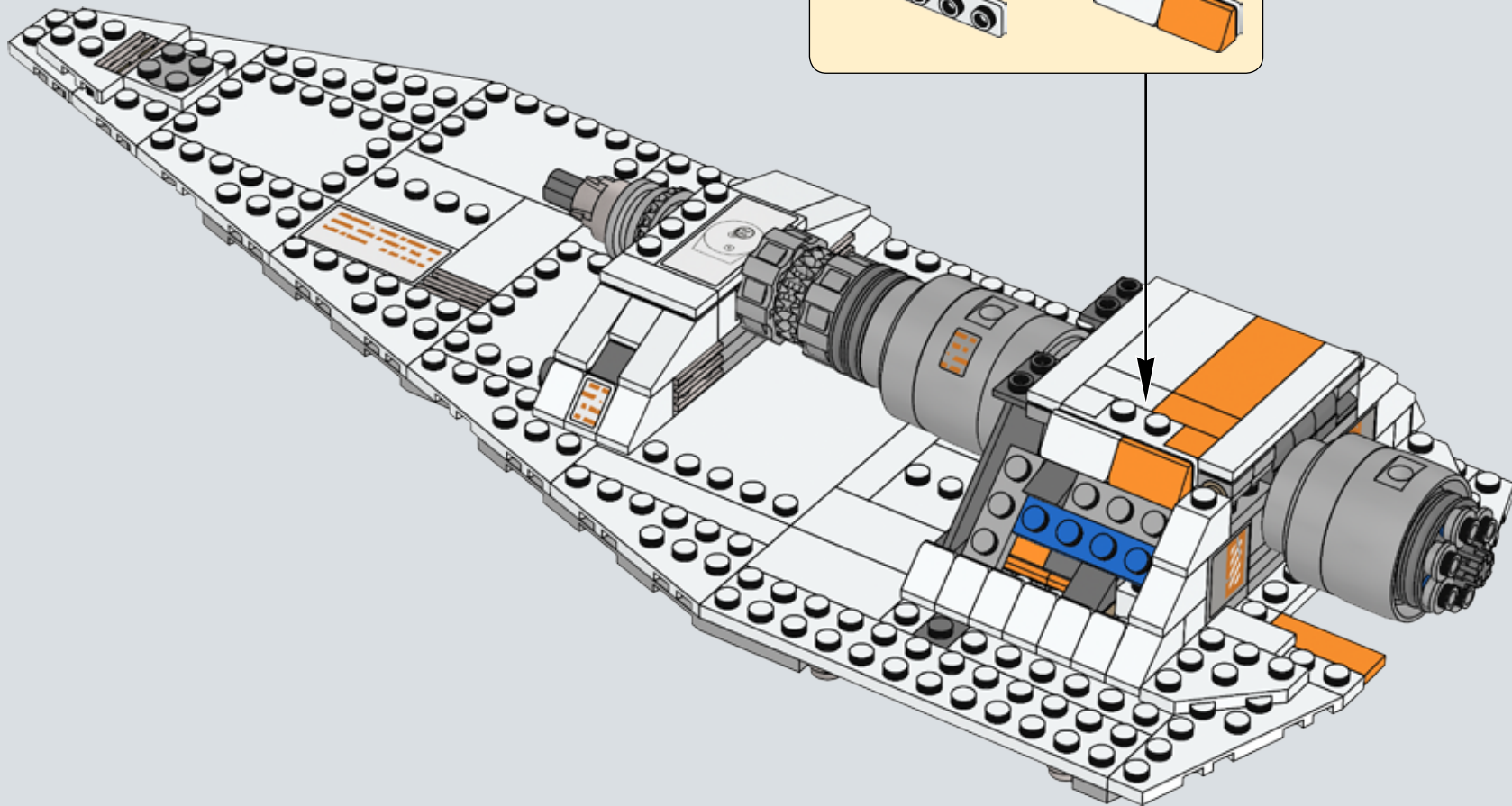
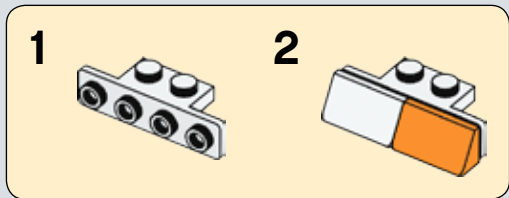
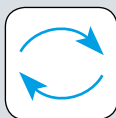

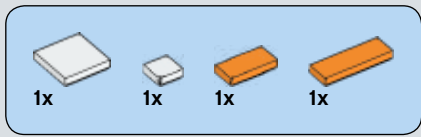

373

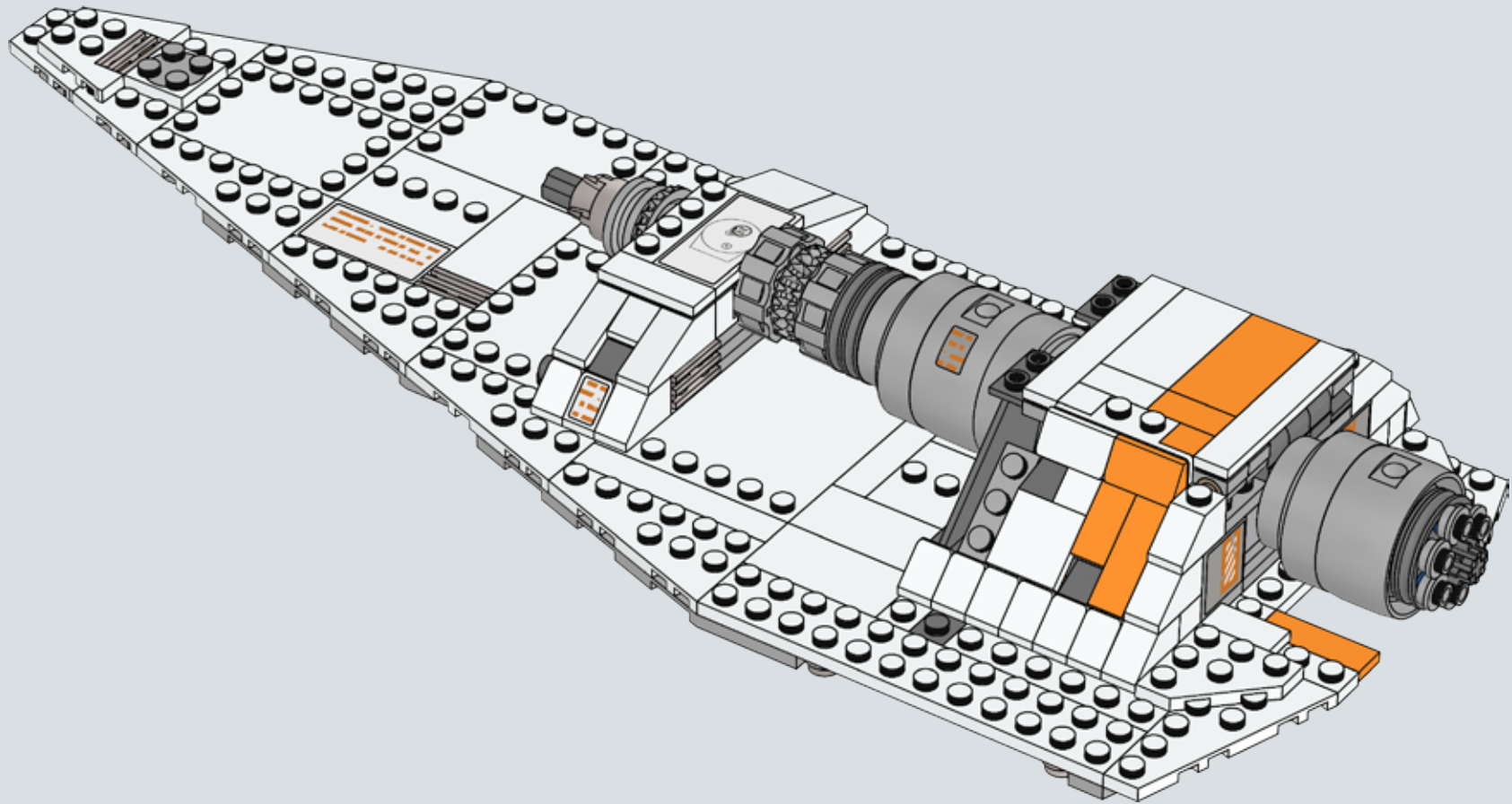

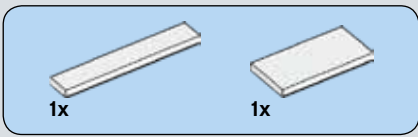

374

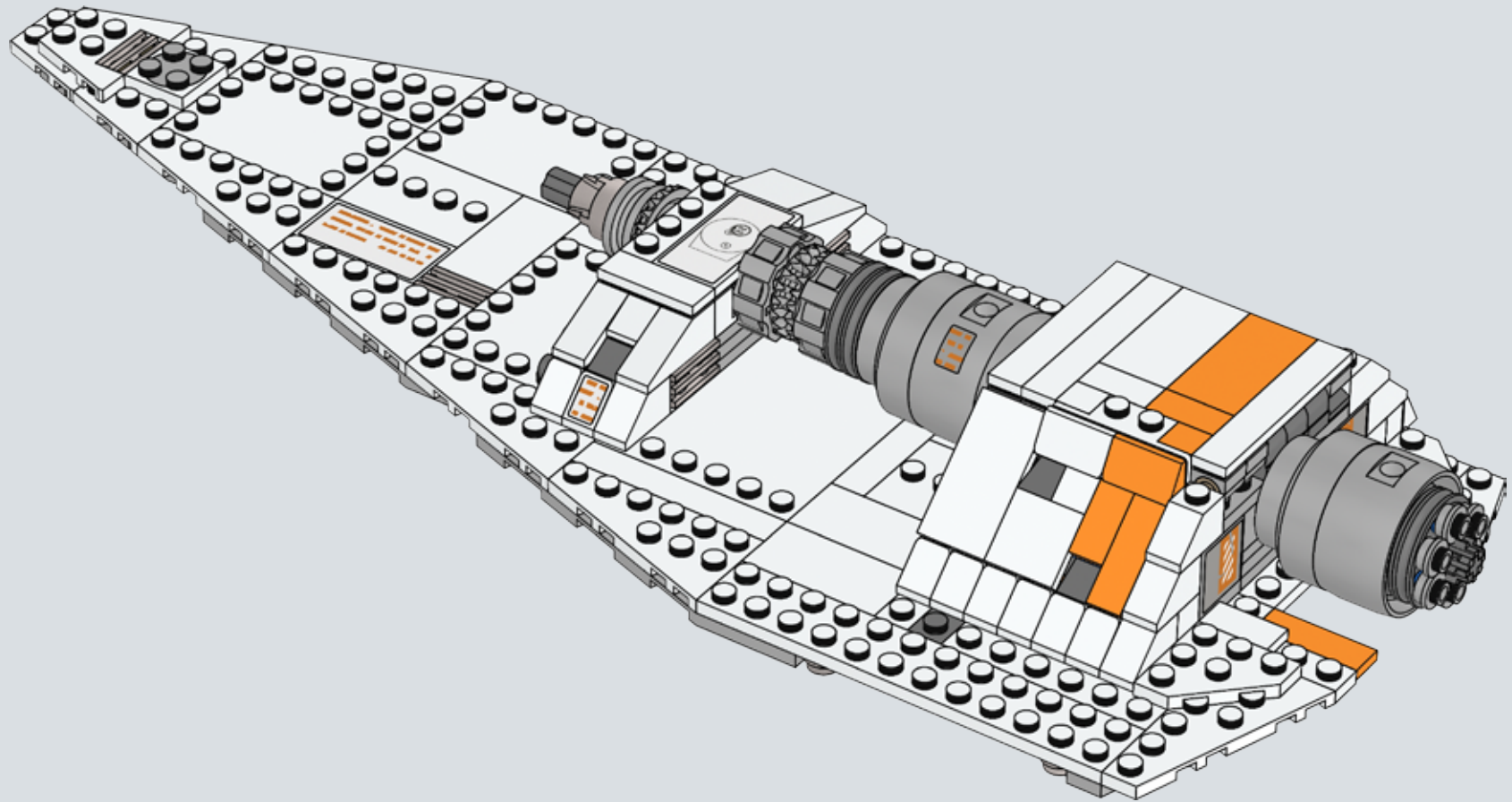



2x



3x

375

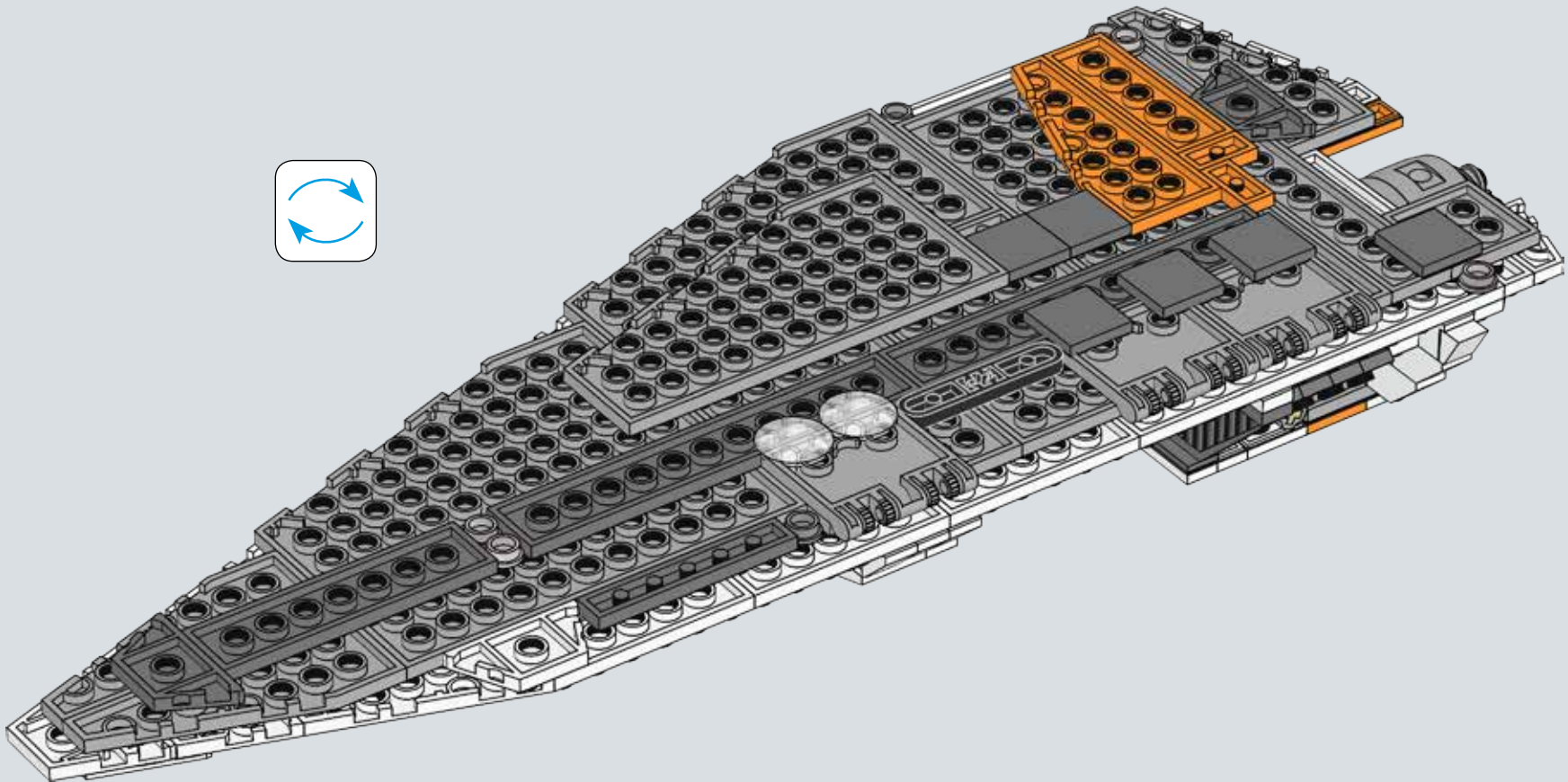
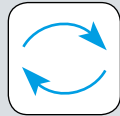

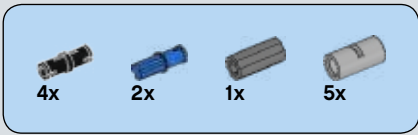

376

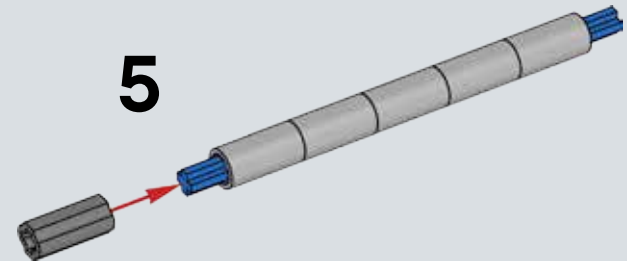
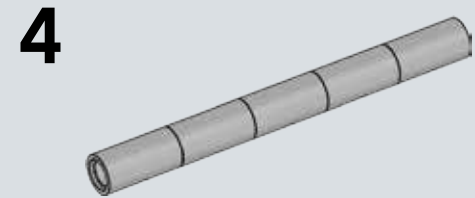
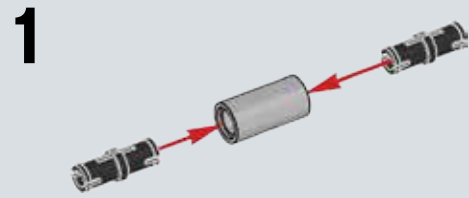

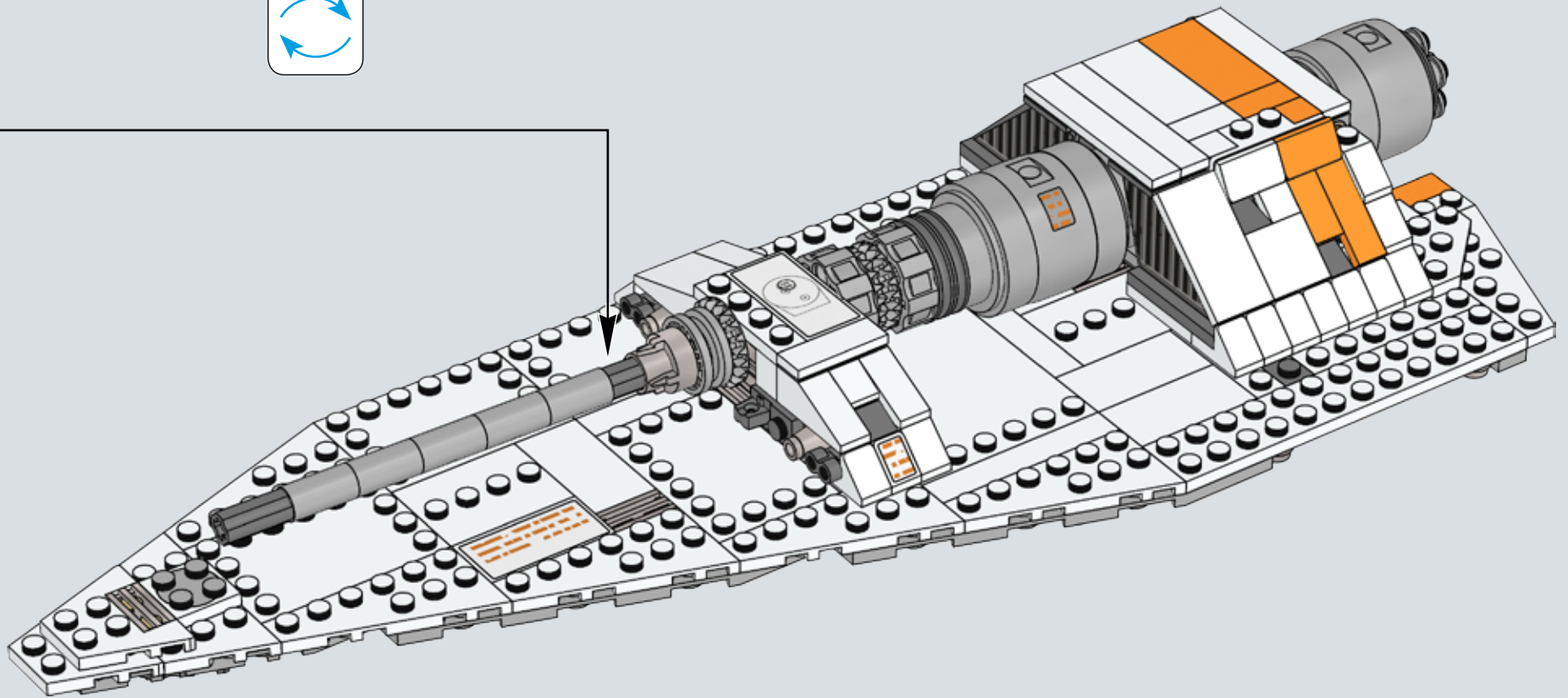
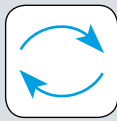

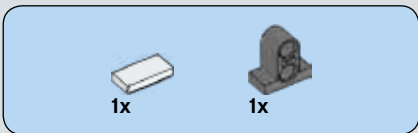

377

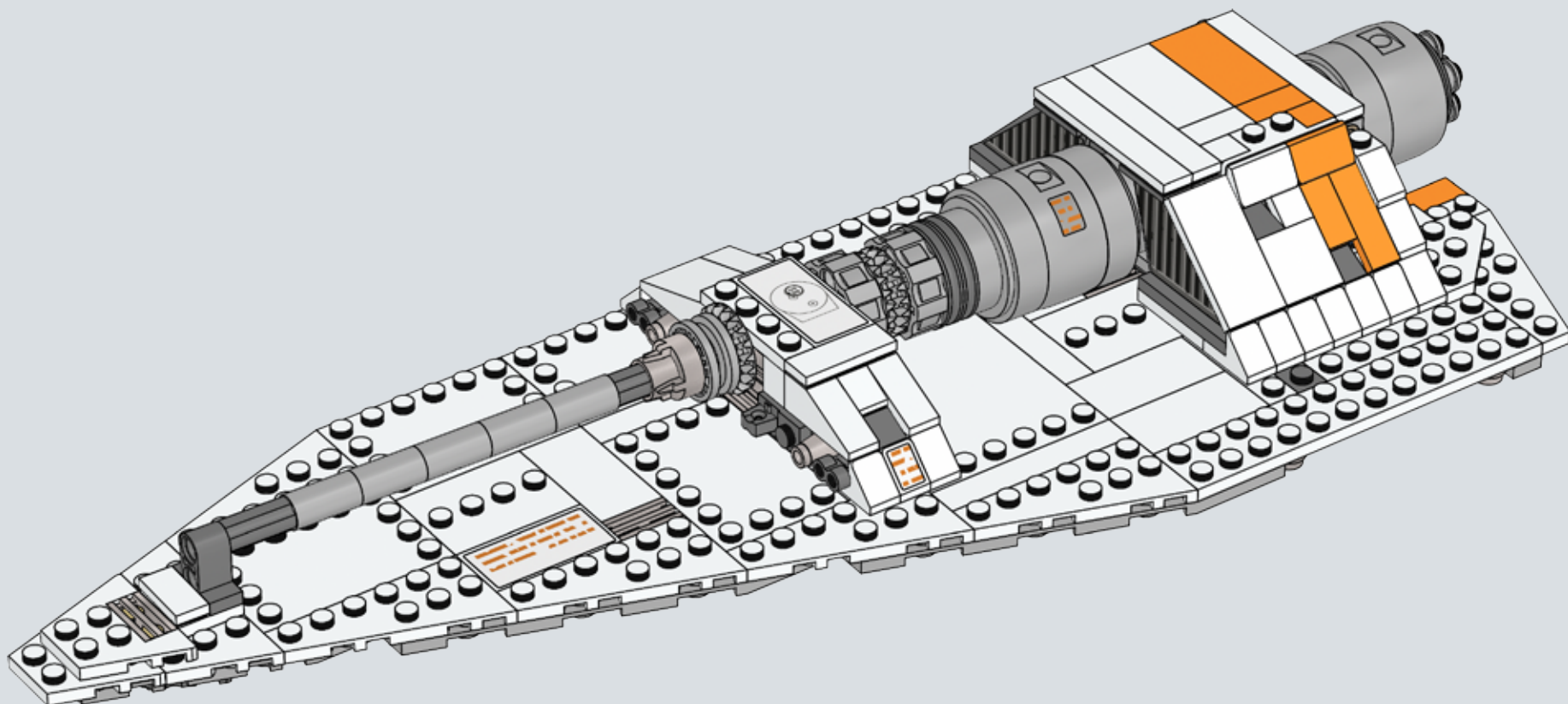

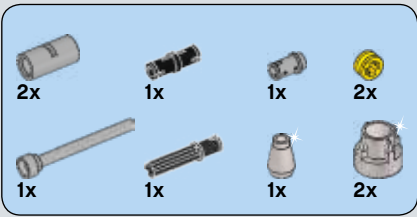

378

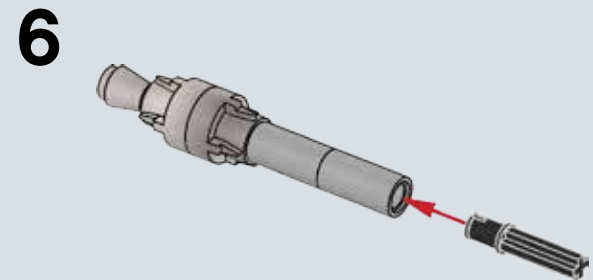
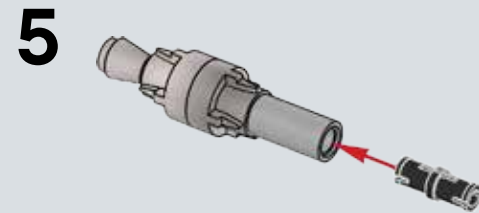
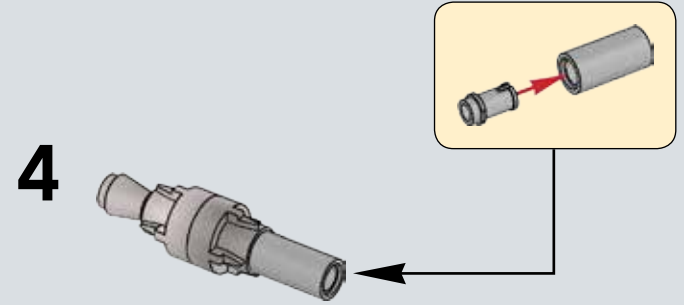
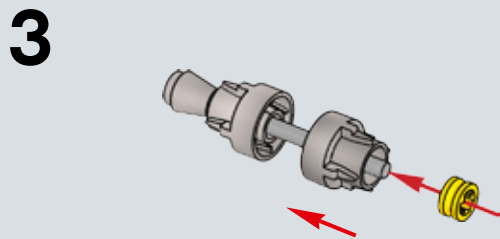
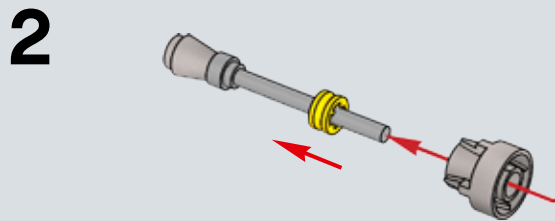
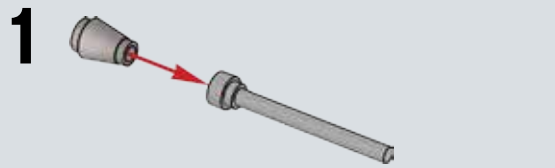

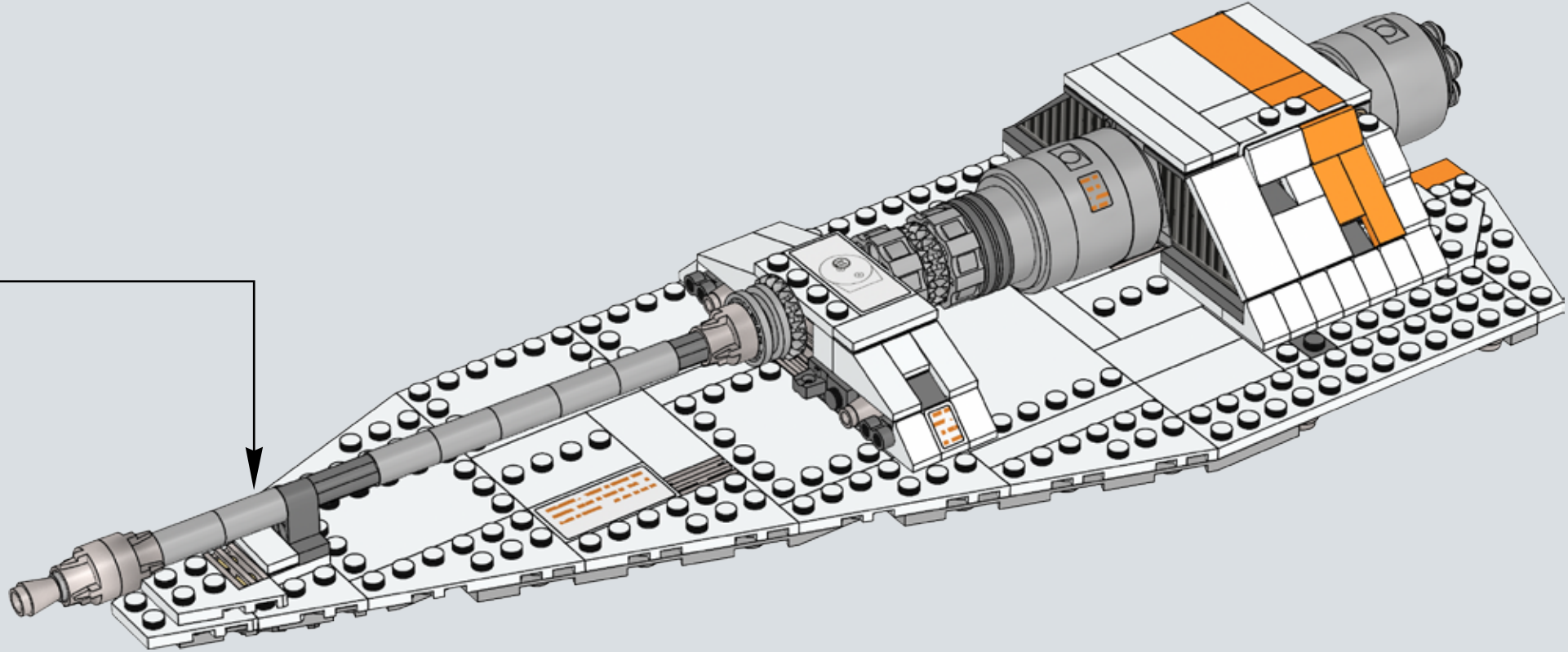

379

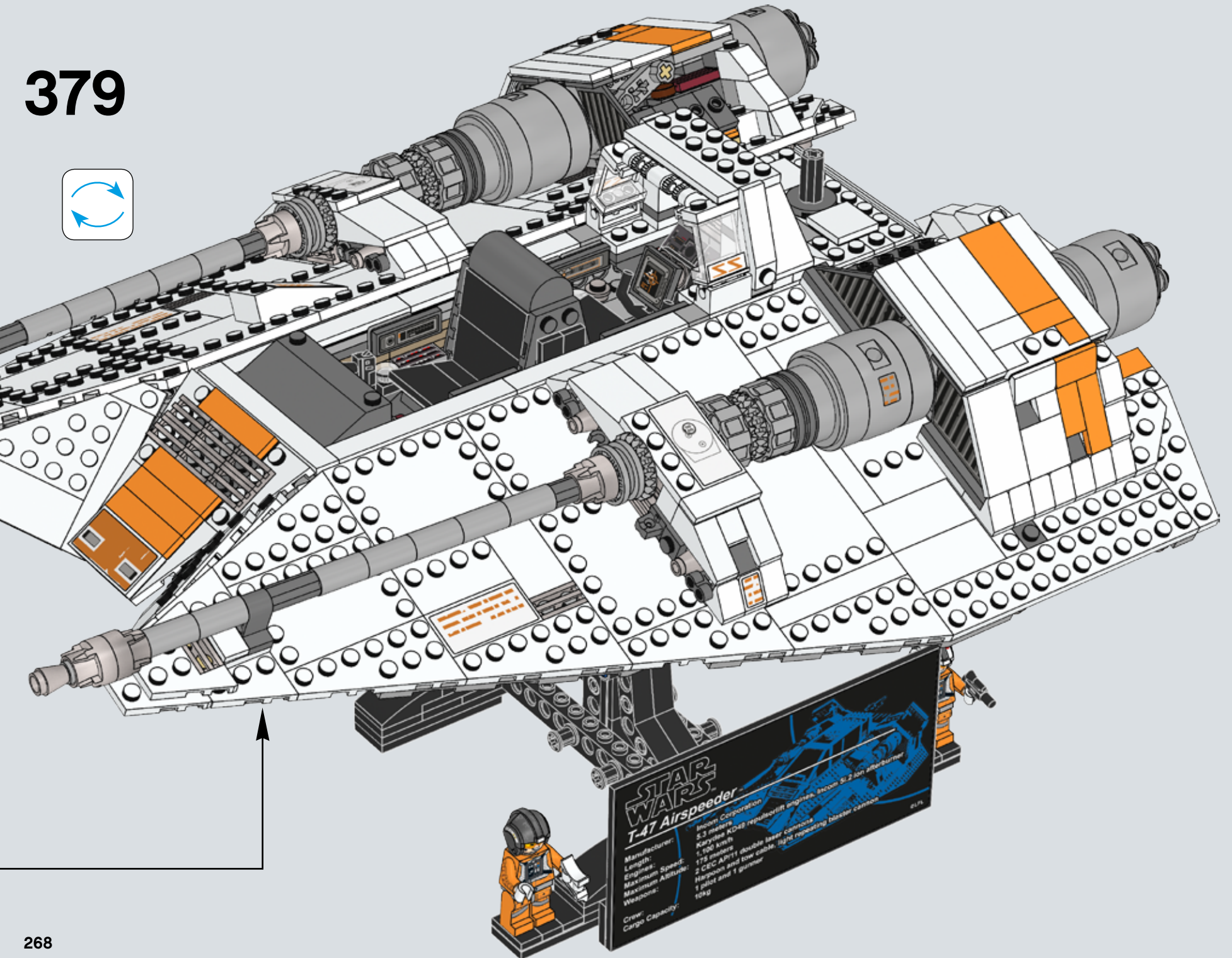
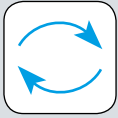

STAR WARS T-47 Airspeeder

Manufacturer:
Length:
Engines:
Maximum Speed:
Maximum Altitude:
Weapons:
Crew:
Cargo Capacity:

Incom Corporation
5.3 meters
Karydea RD49 repulsorlift engines, Incom S-2 ion afterburner
1,100 km/h
175 meters
2 CEC AP111 double laser cannons
Harpoon and tow cable, light repeating blaster cannons
1 pilot and 1 gunner

6171

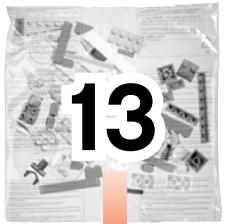

13

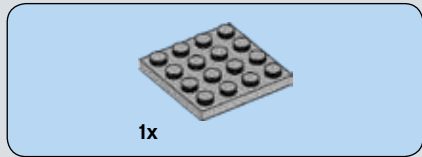
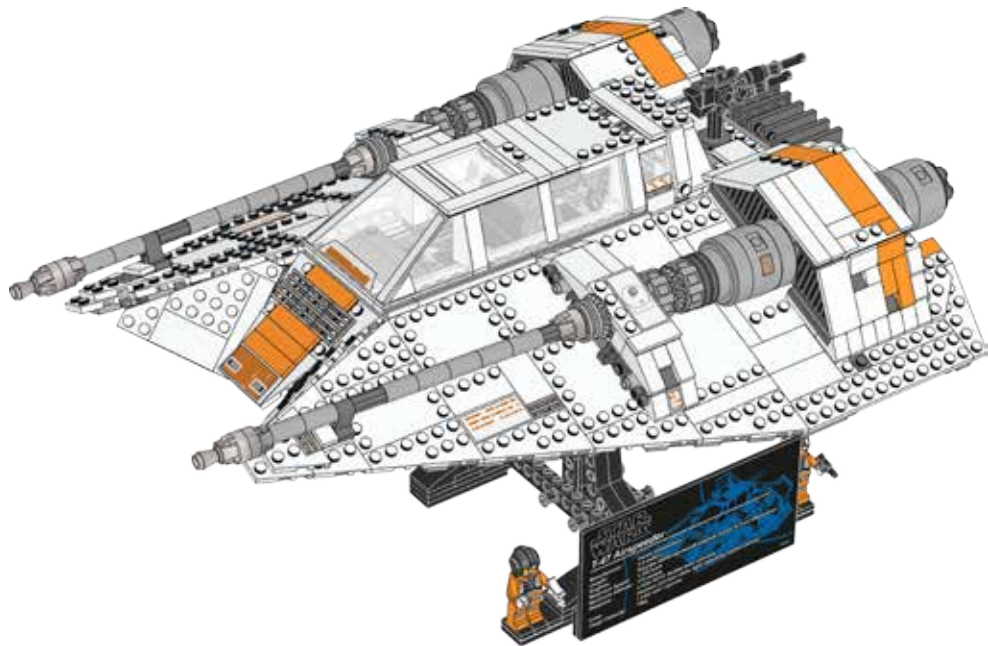

380



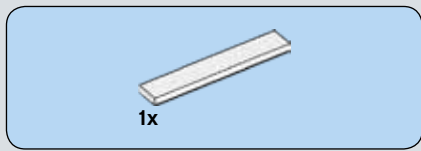

381

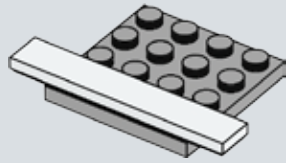

382

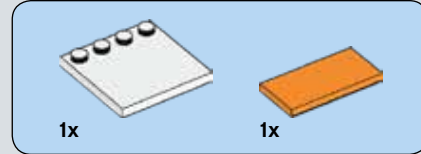
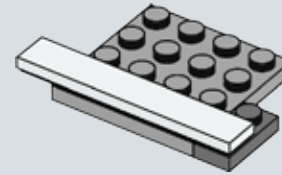

383

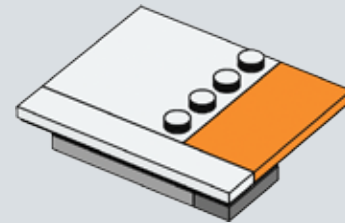

384

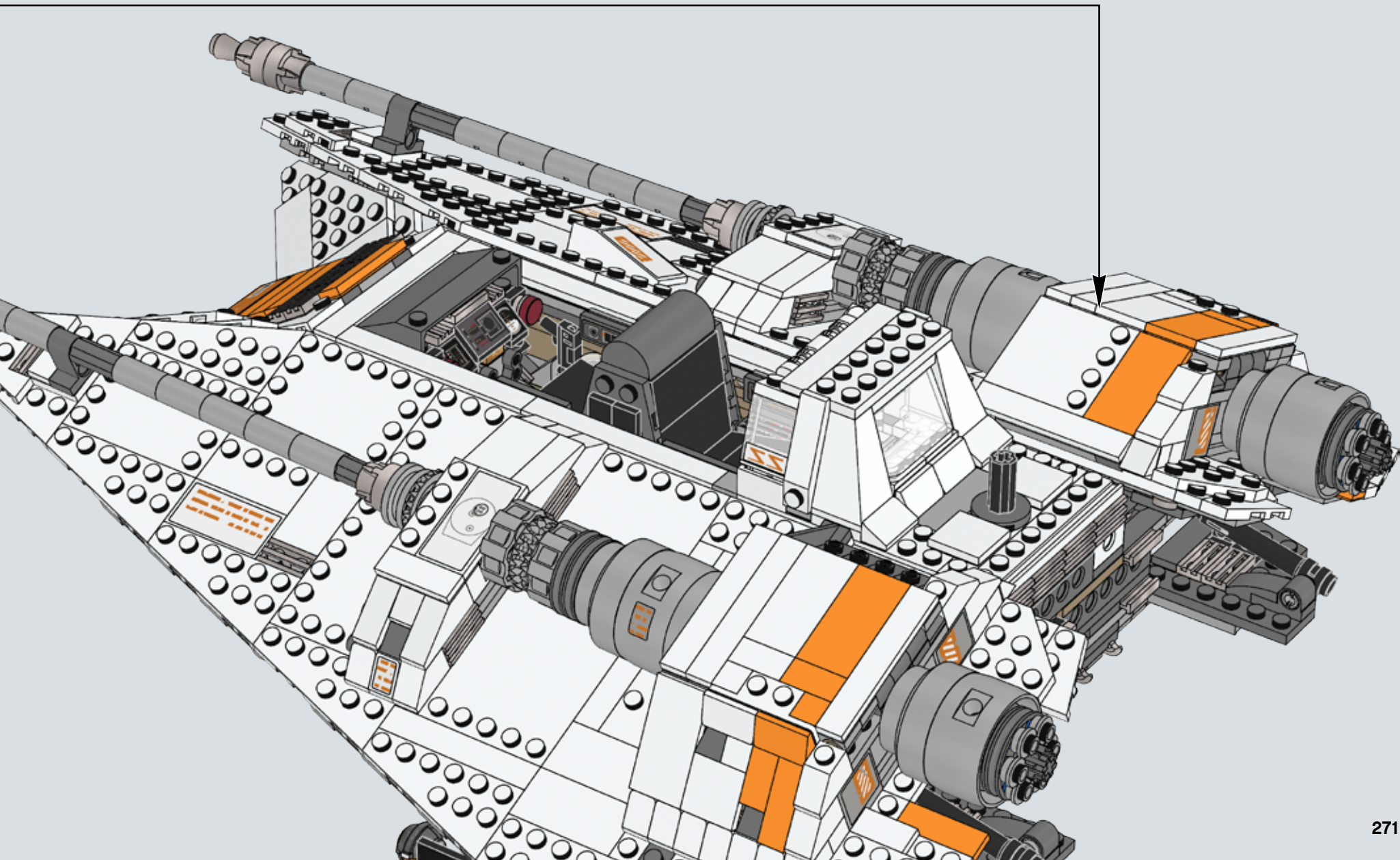

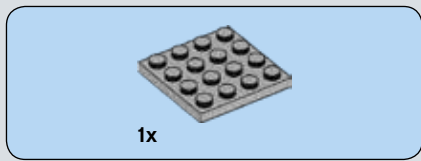

385

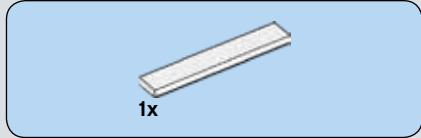

386

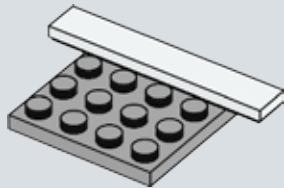

387

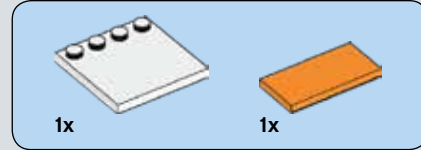
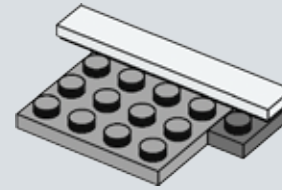

388

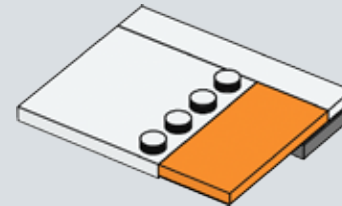

389

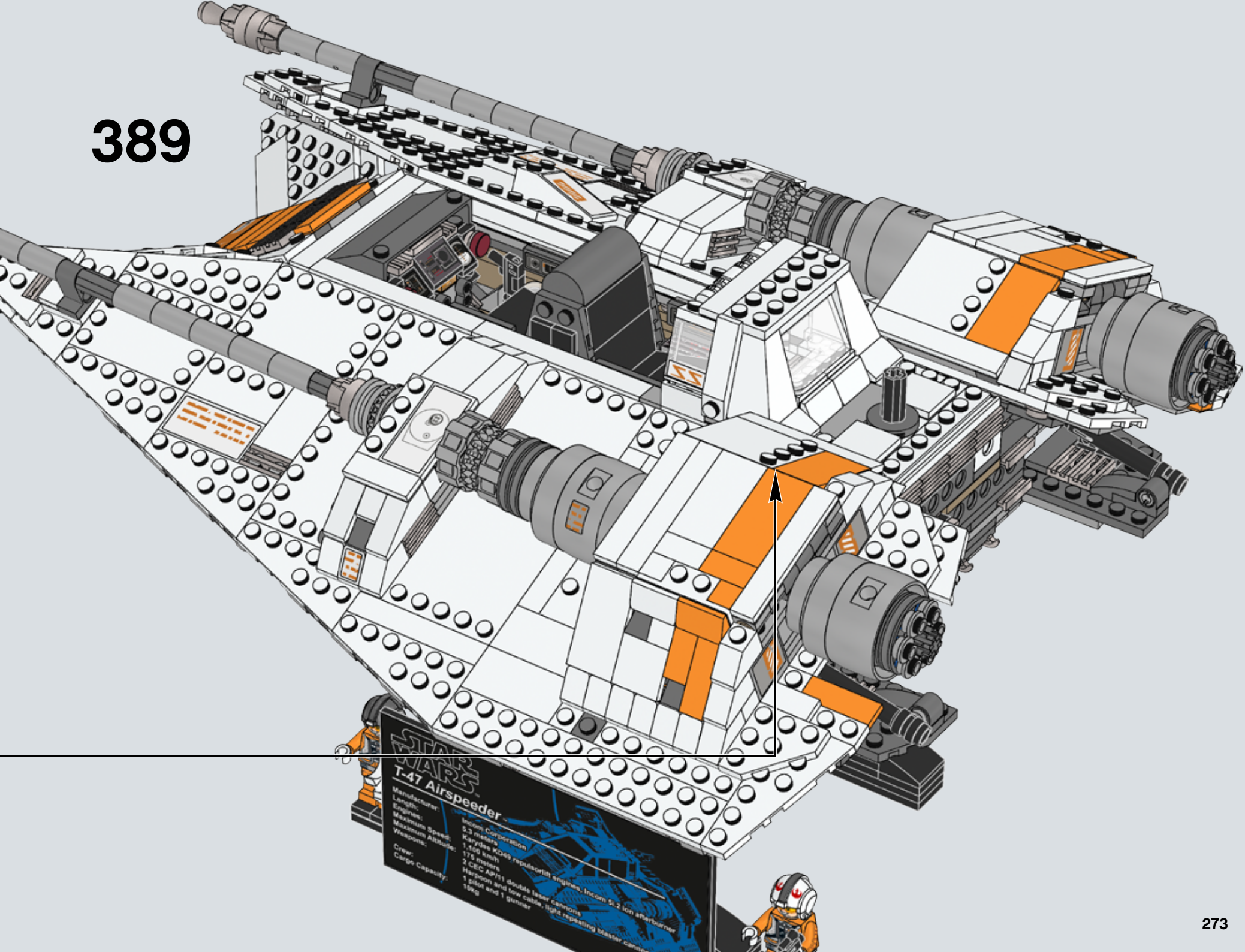

STAR WARS
T-47 Airspeeder

Manufacturer: Incom Corporation
Length: 5.3 meters
Engine: Karydes KD49 repulsorlift engines, Incom S-2 Ion afterburner
Maximum Speed: 1,160 km/h
Maximum Altitude: 175 meters
Weapons: 2 CEC AP-11
Crew: Harrison and two cables, light repeating blaster cannons
Cargo Capacity: 1 pilot and 1 gunner
16kg

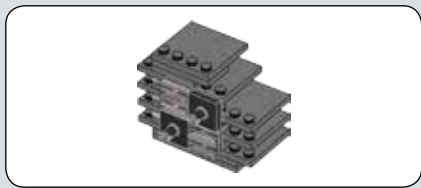

390

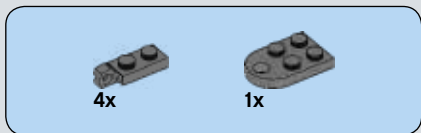
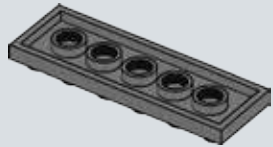

391

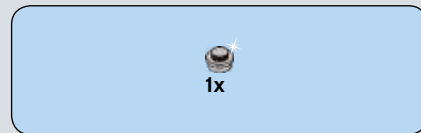
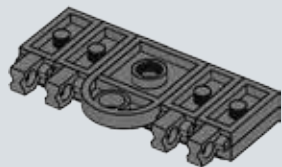

392

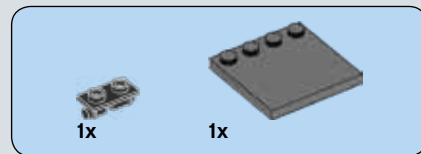
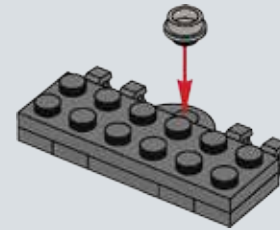
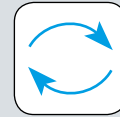

393

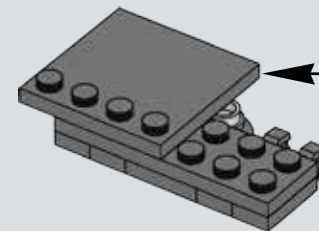
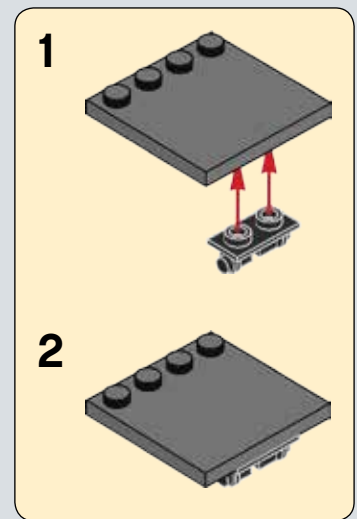

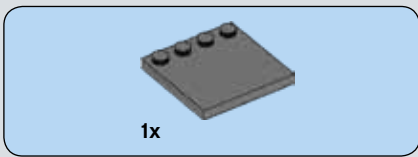

394

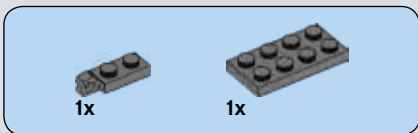
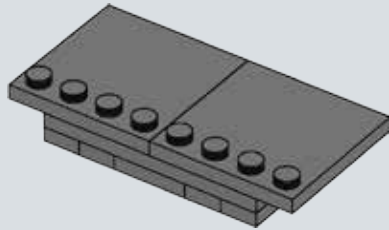

395

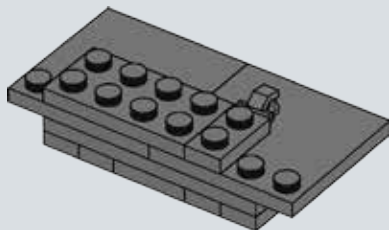

396

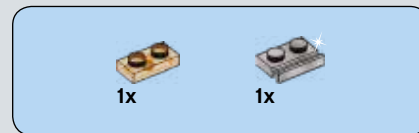
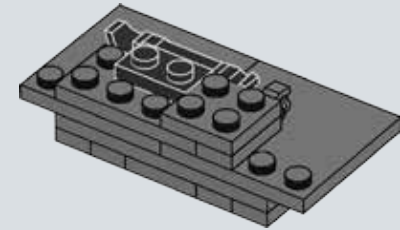

397

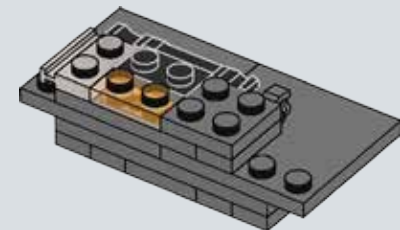

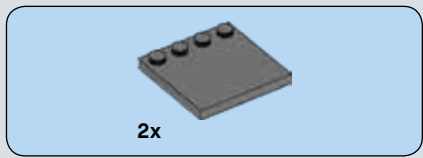

398

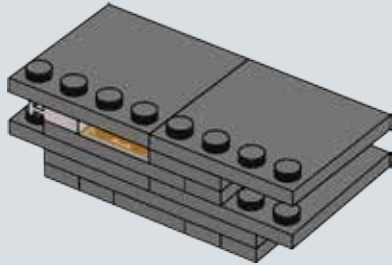

399

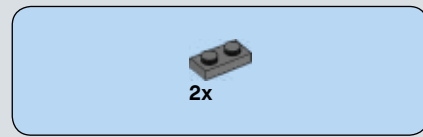
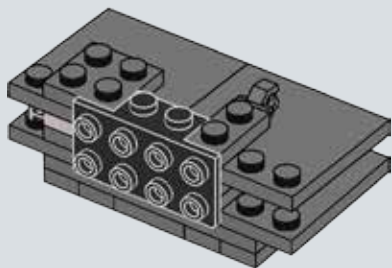

400

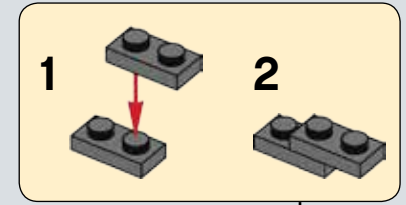
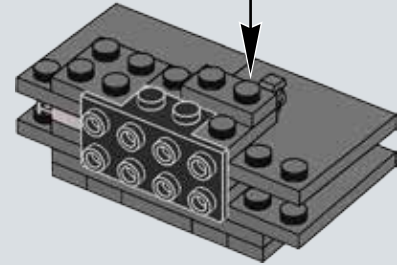

401

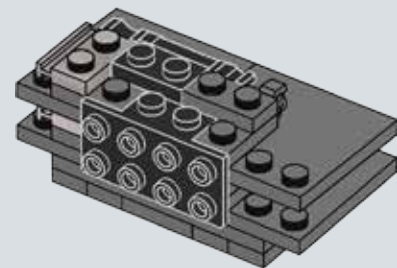



2x

402

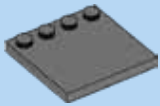
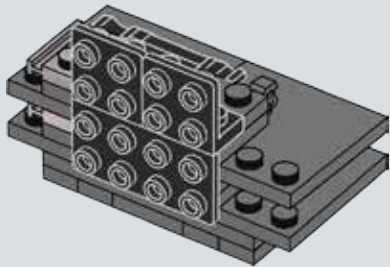

2x

403

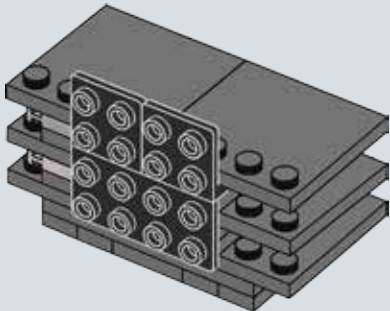

1x

404

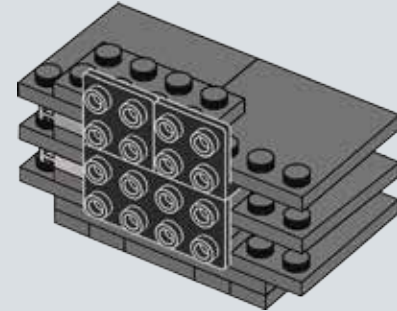

1x



2x



2x

405

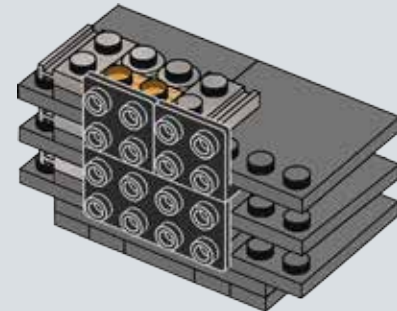

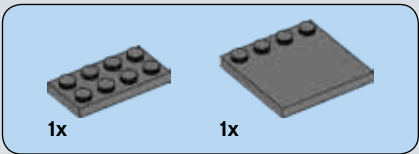

406

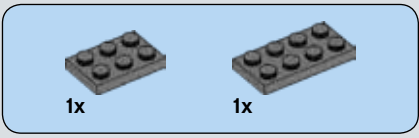
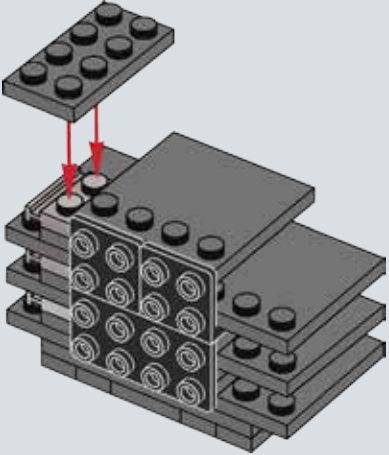

407

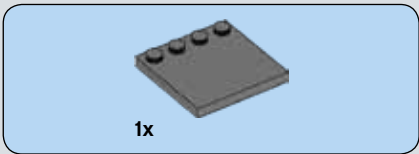
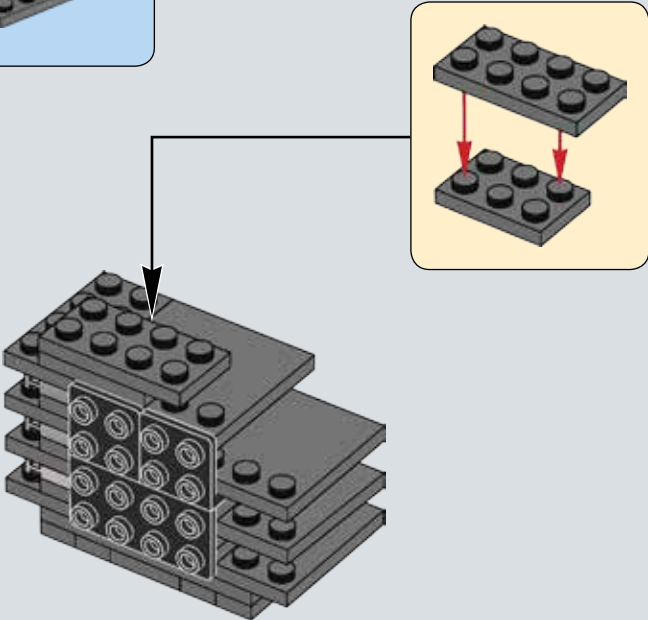

408

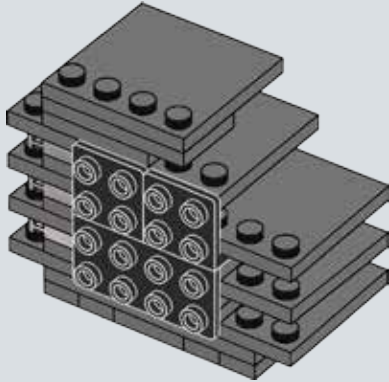

409

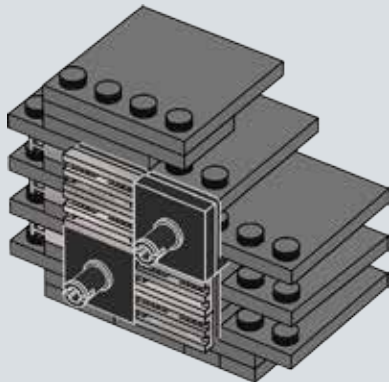

410

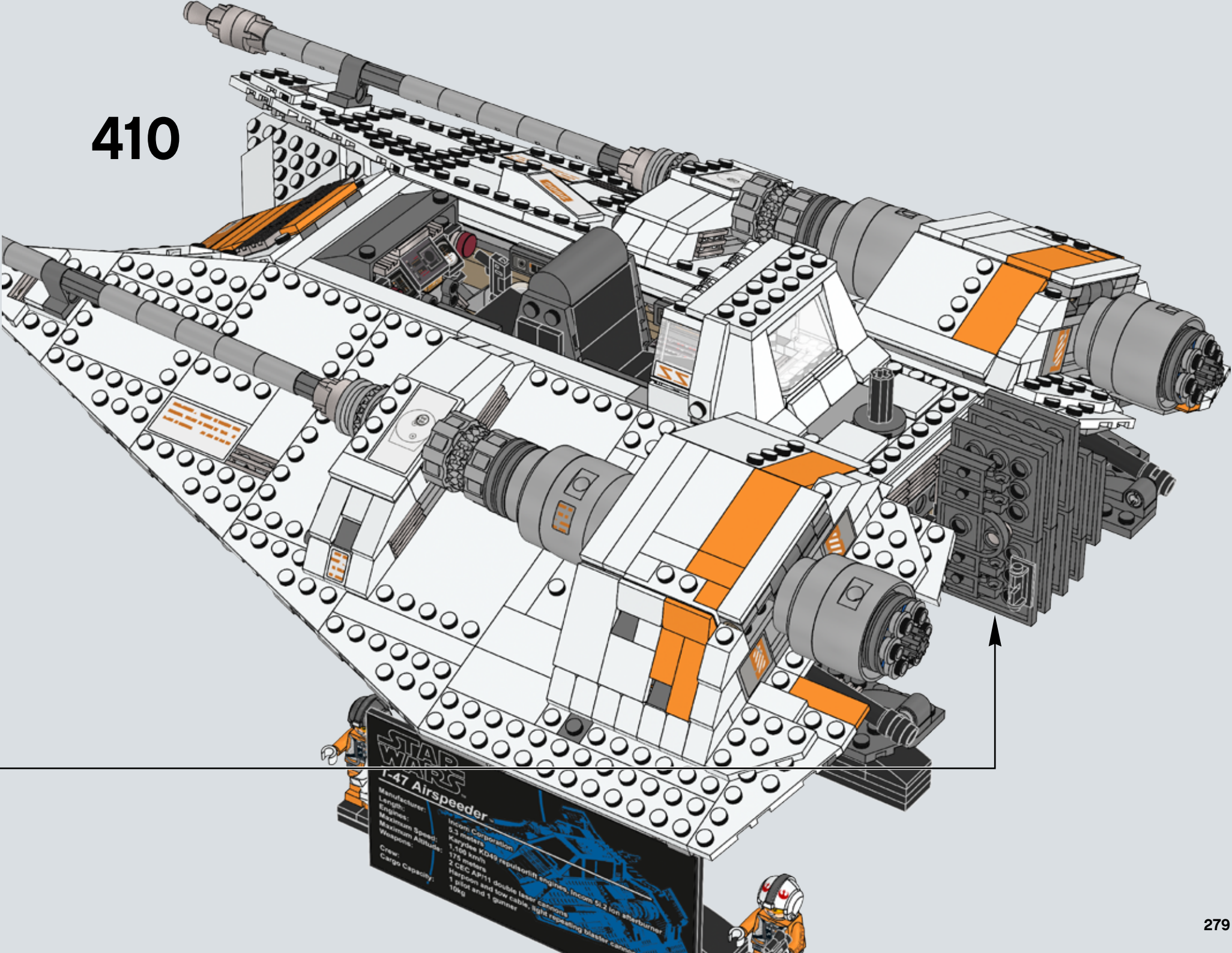

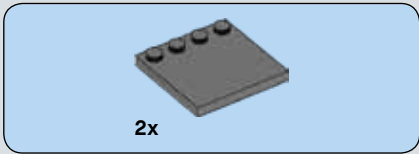
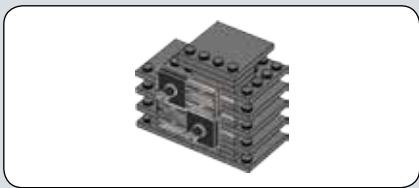

411

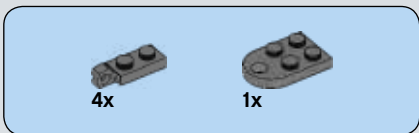
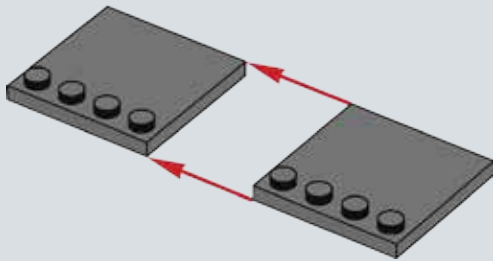

412

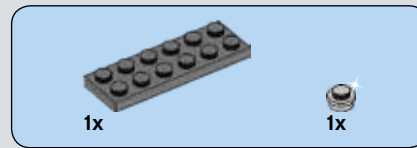
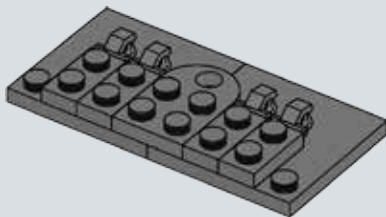

413

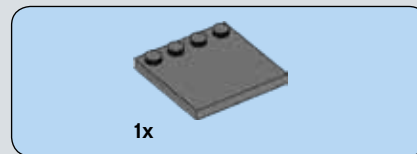
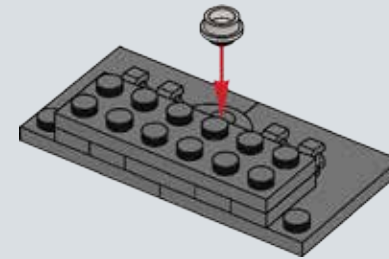

414

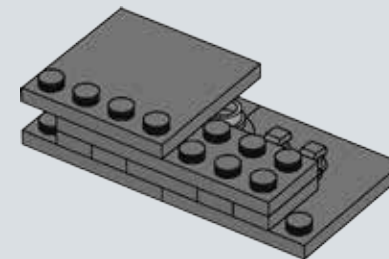

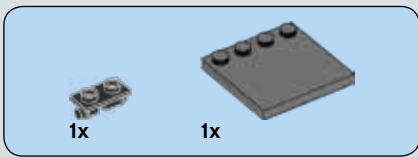

415

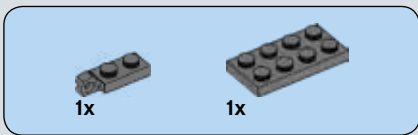
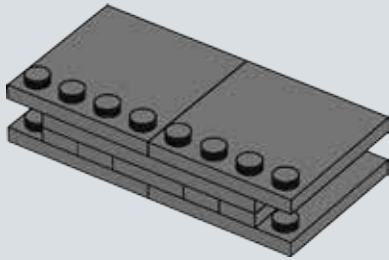
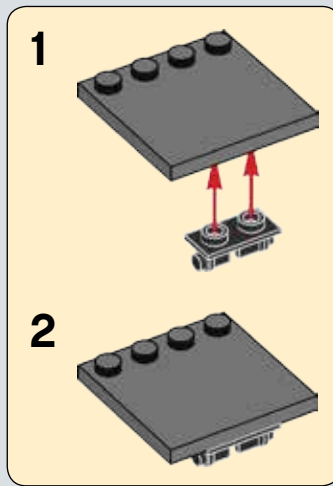

416

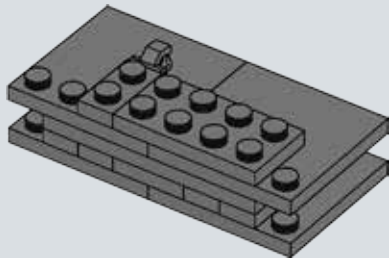

417

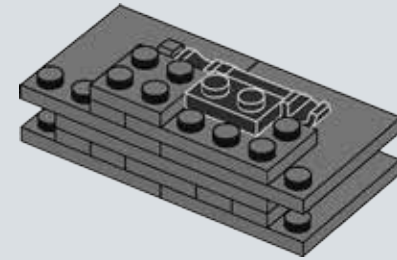

418

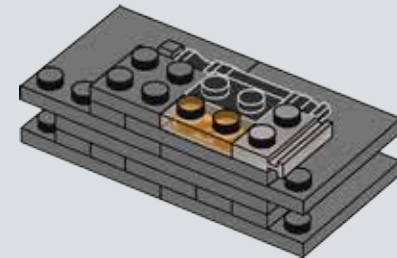

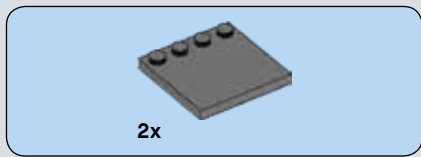

419

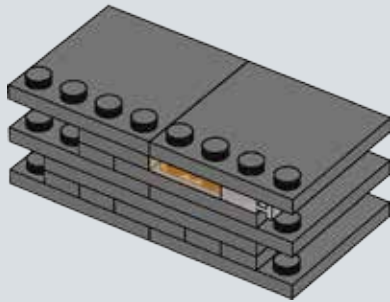

420

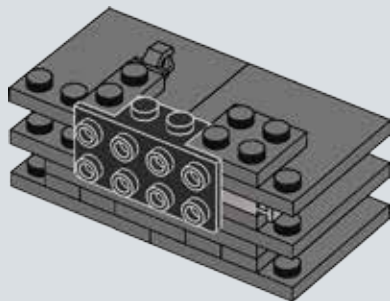

421

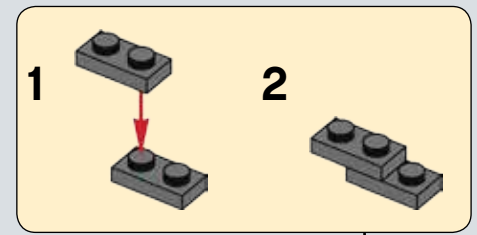
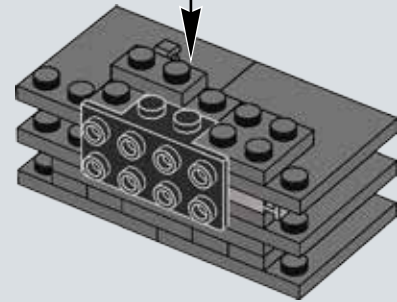

422

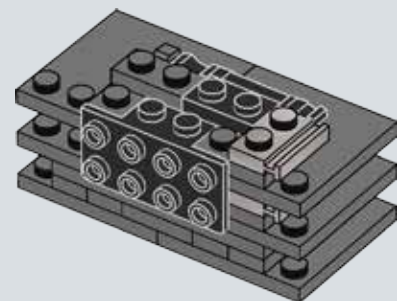



2x

423

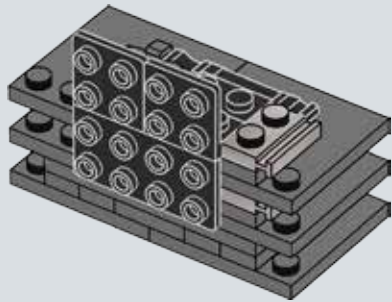

2x

424

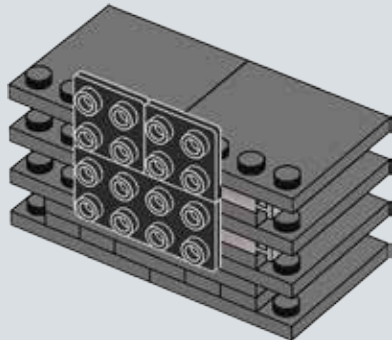

1x

425

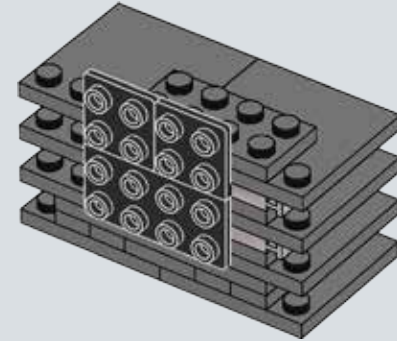

1x



2x



2x

426

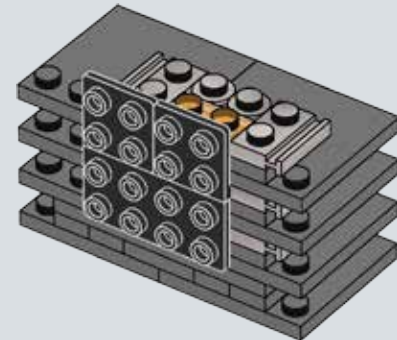

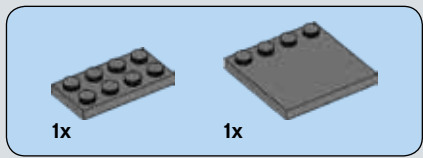

427

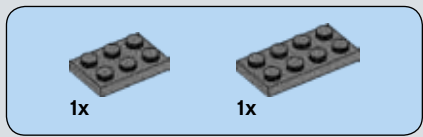
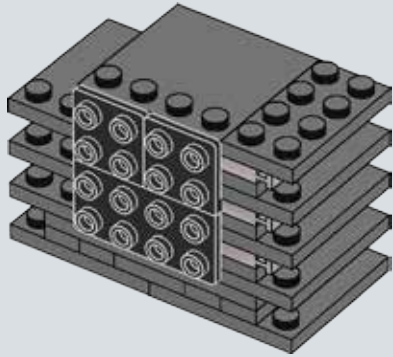

428

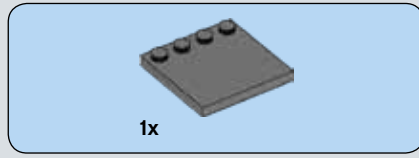
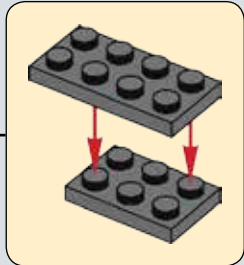
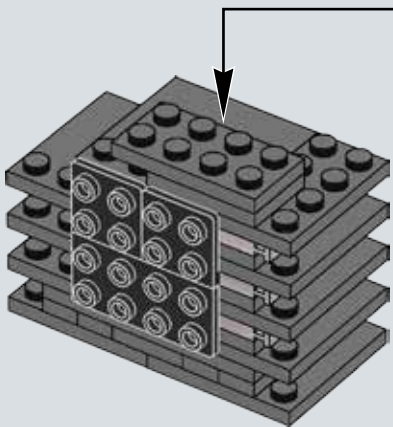

429

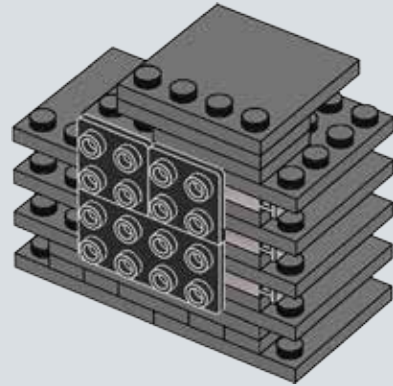

430

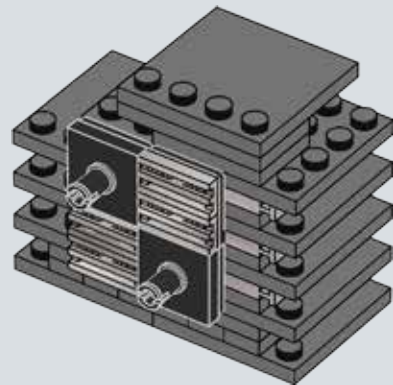

431

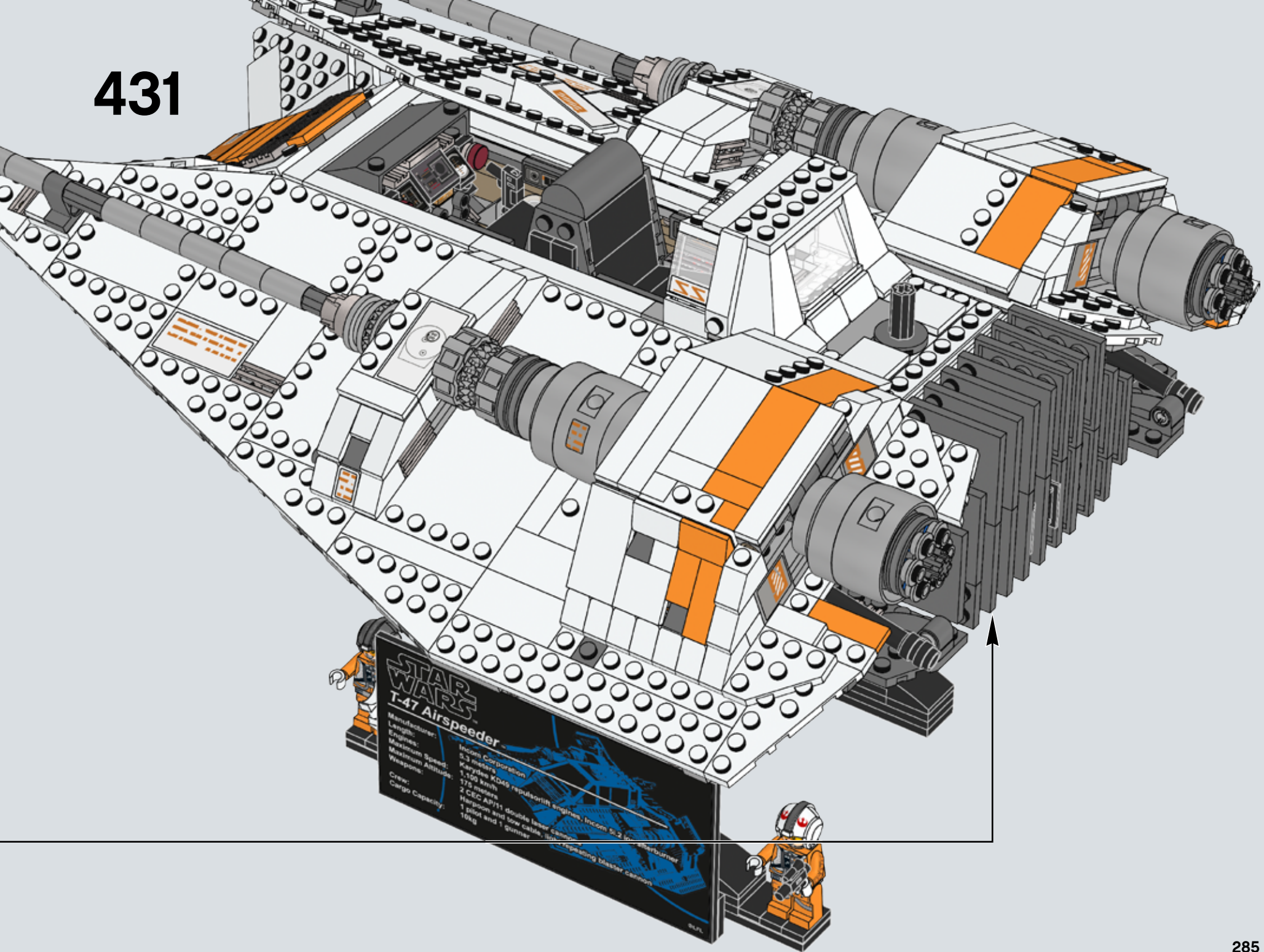

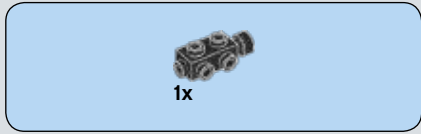

432

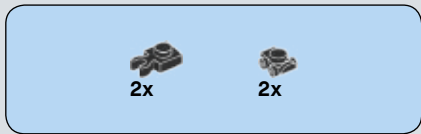

433

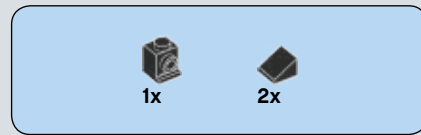
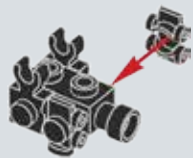

434

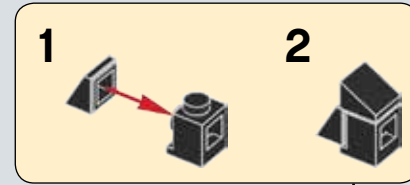

435

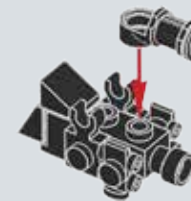



1x

436

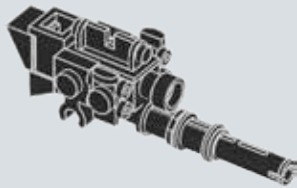
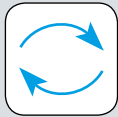

1x



1x



1x

437

1



2

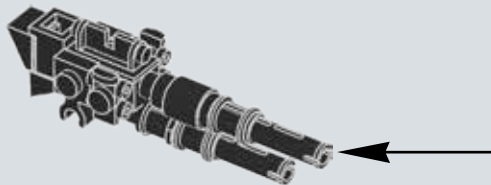

1x

438

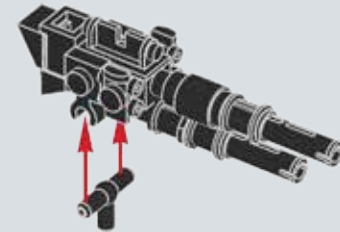

439

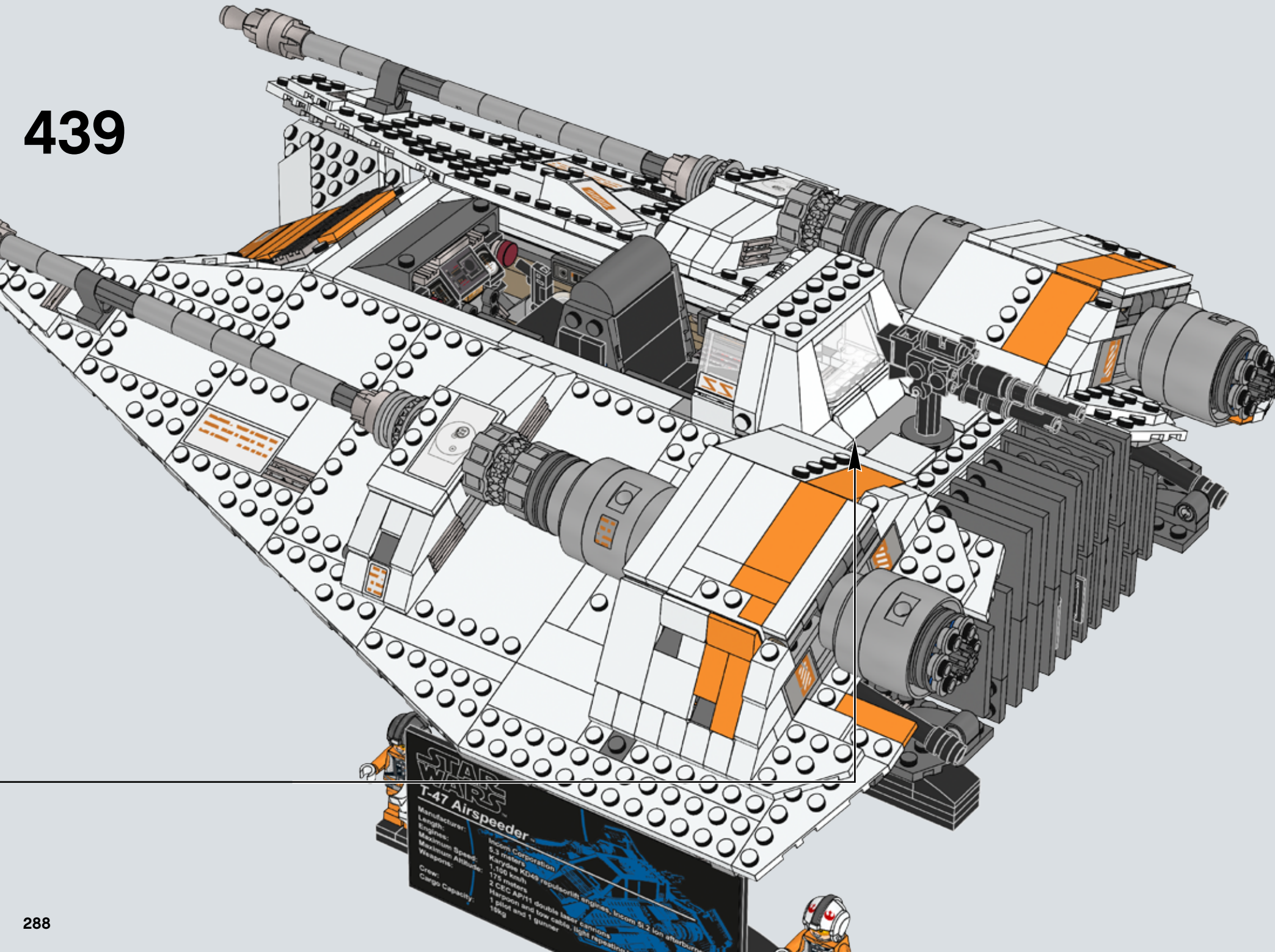

STAR WARS
T-47 Airspeeder

Manufacturer:	Incom Corporation
Length:	5.3 meters
Engines:	Karysae KD69 repulsorlift engines, Incom SL2 ion afterburner
Maximum Speed:	1,100 km/h
Maximum Altitude:	175 meters
Weapons:	2 CEC A8/11 double laser cannons Harpoon and low caliber, light repeating blaster
Crew:	1 pilot and 1 gunner
Cargo Capacity:	15kg

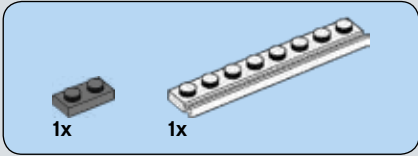
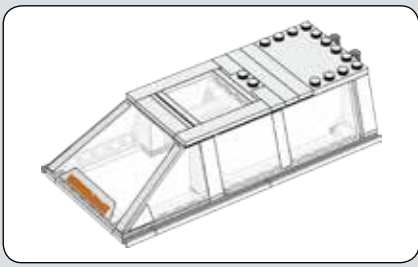

440

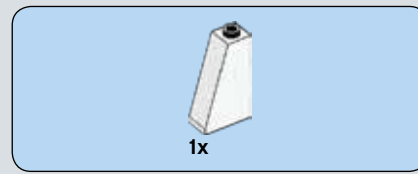
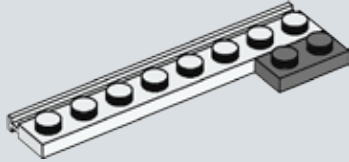

441

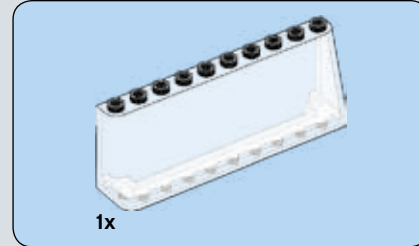
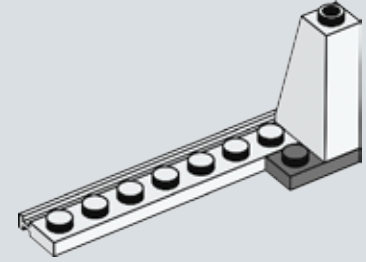

442

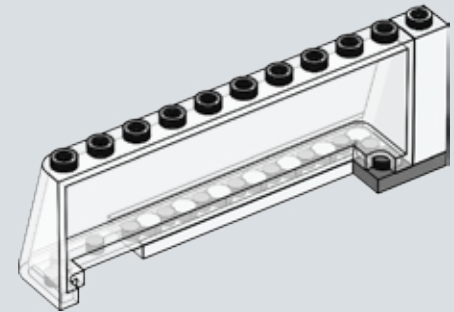

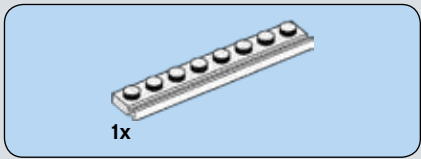

443

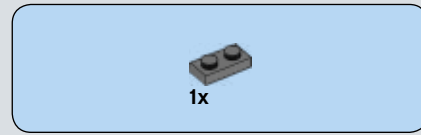
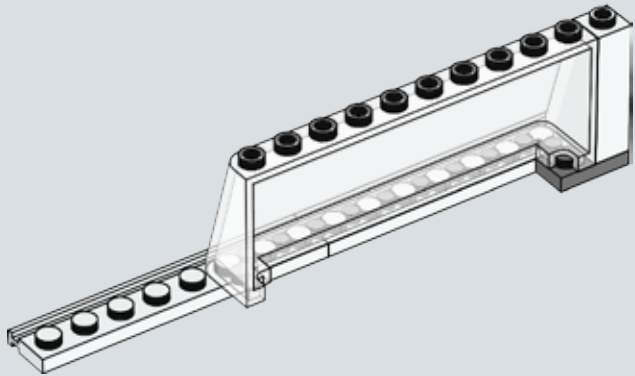

444

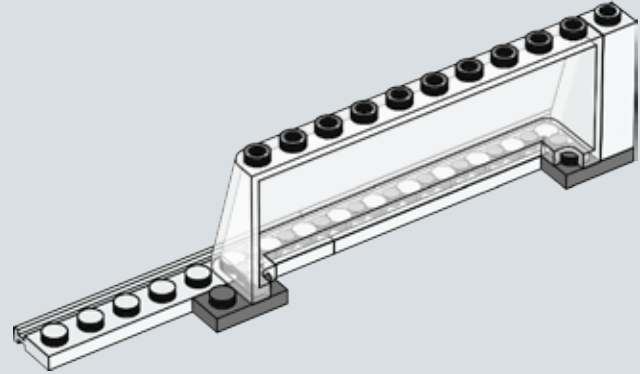

445

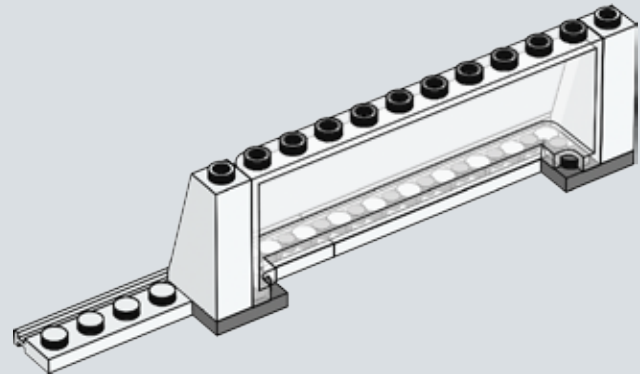

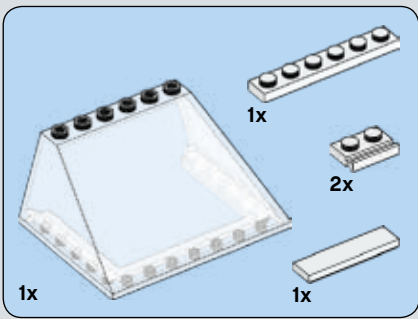

446

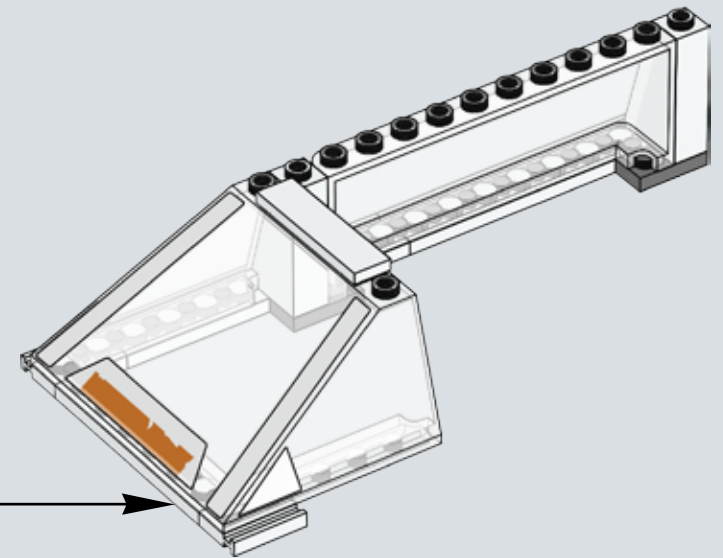
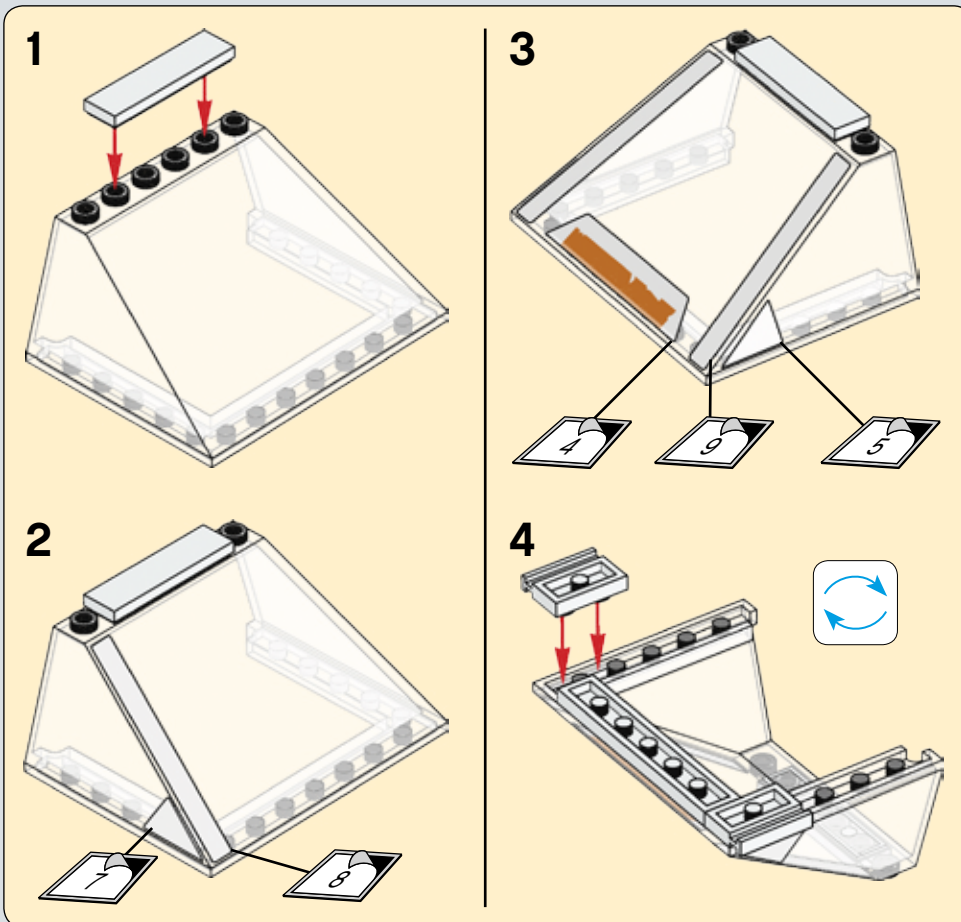

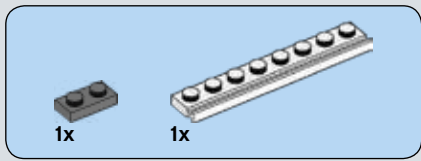

447

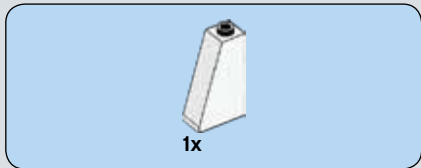
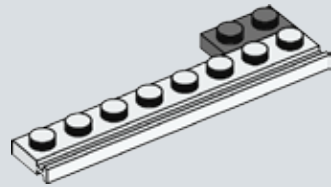

448

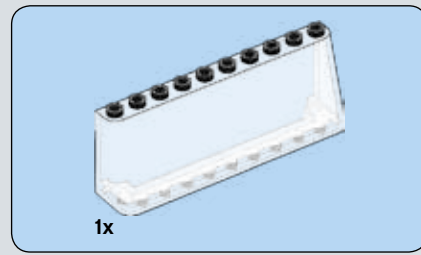
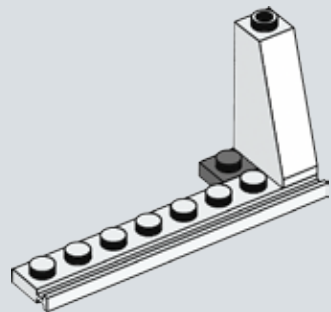

449

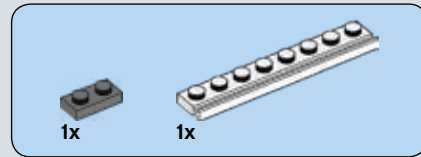
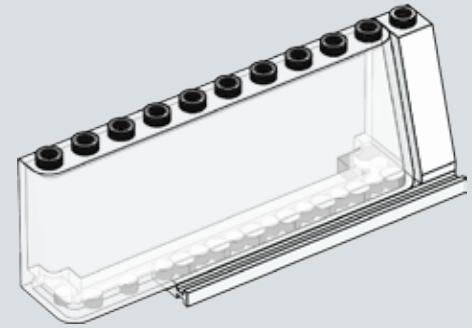

450

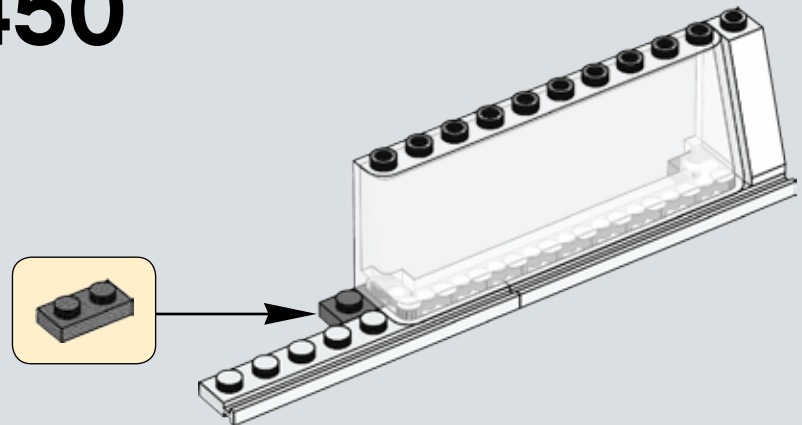

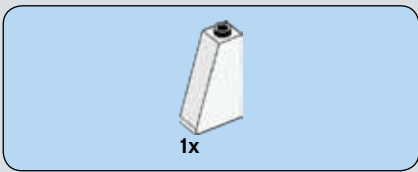

451

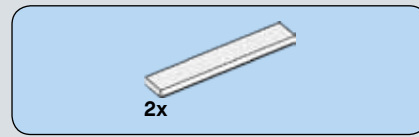
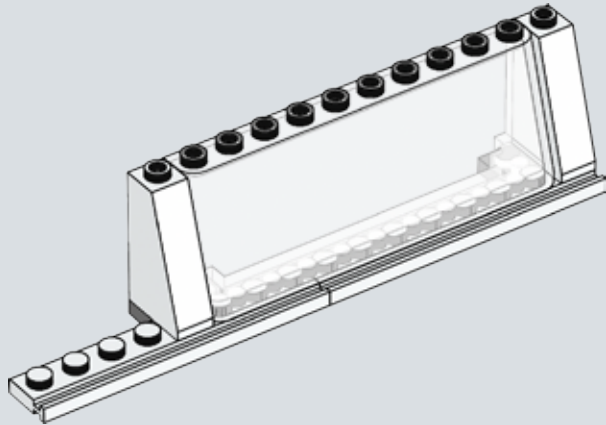

453

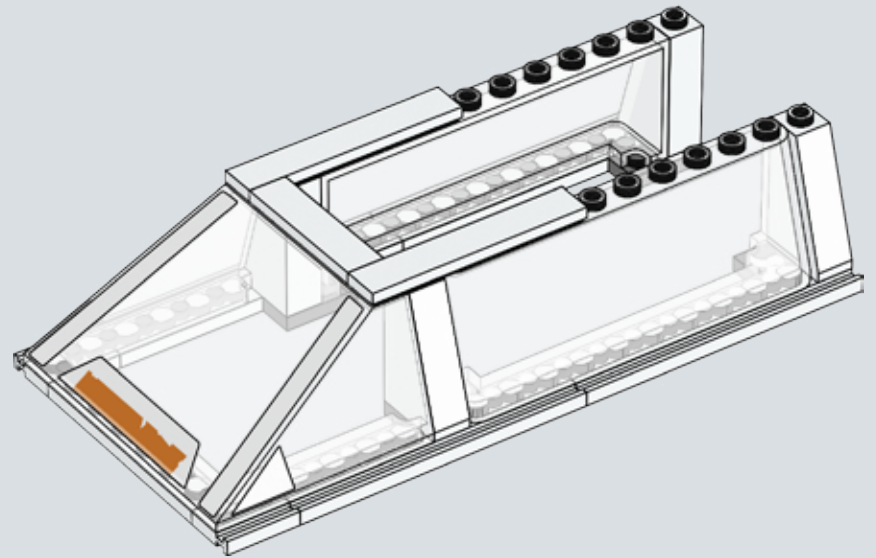

452

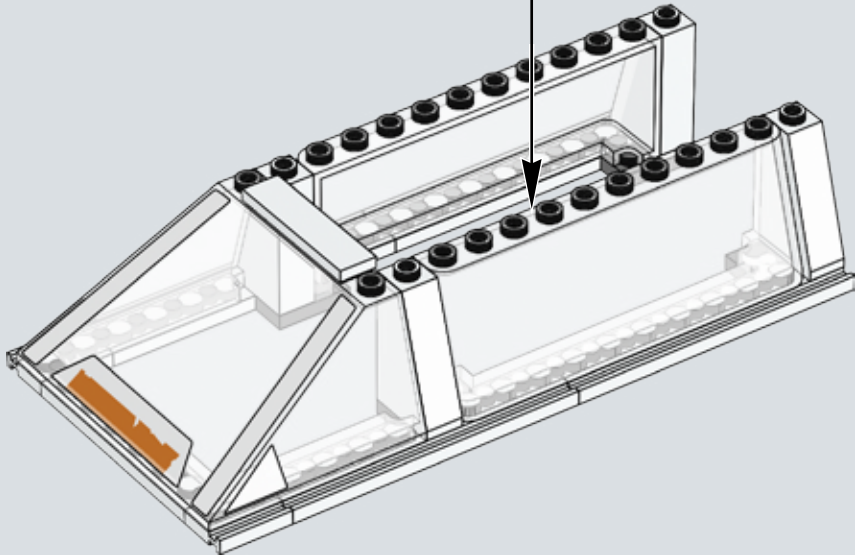

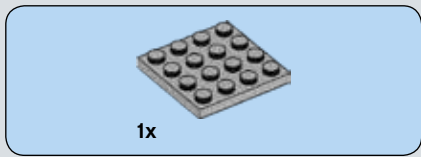

454

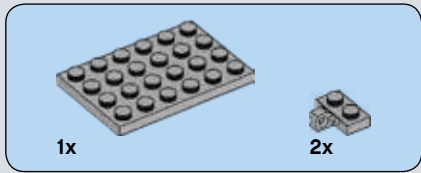

455

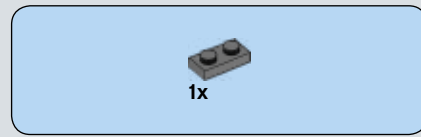
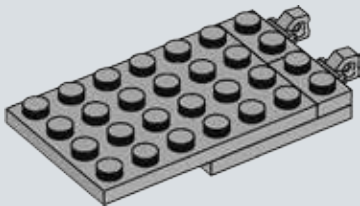

456

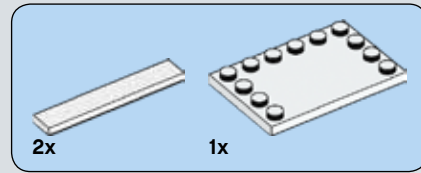
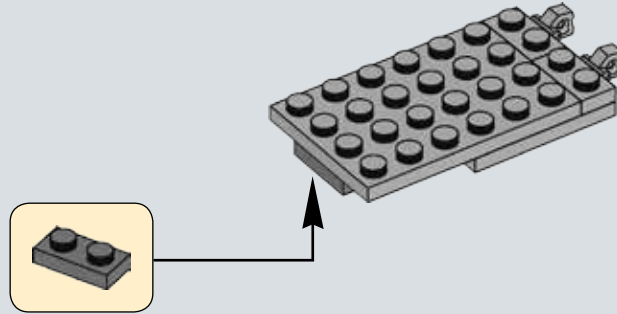

457

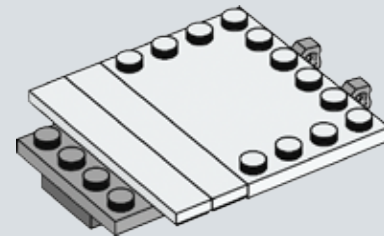

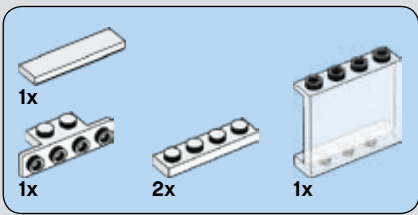

458

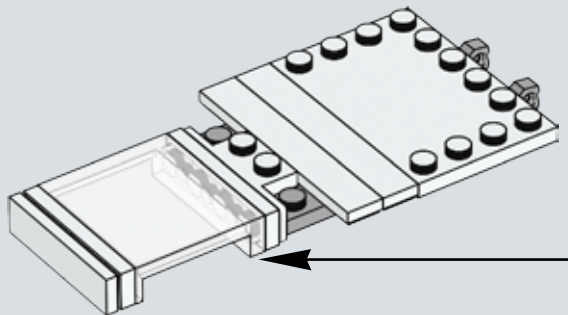
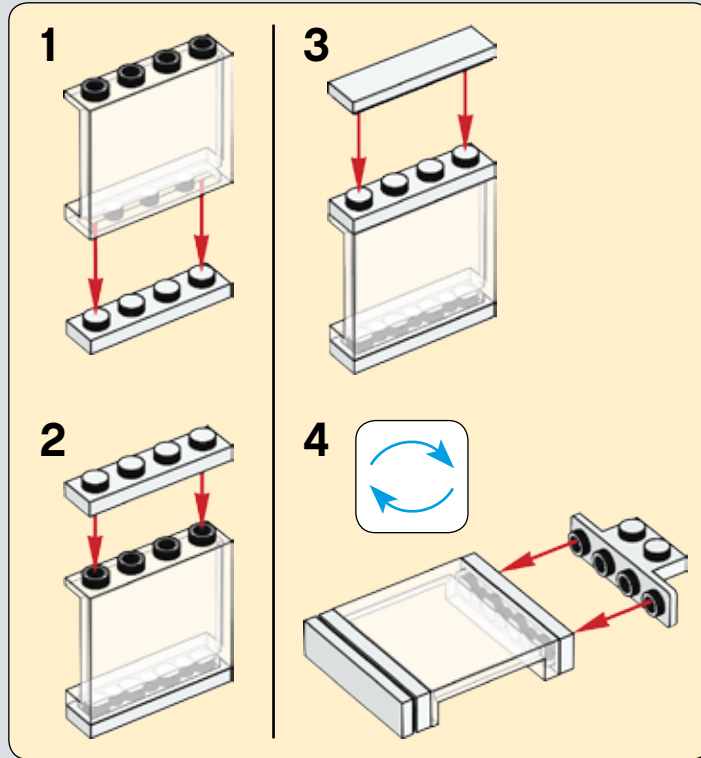

459

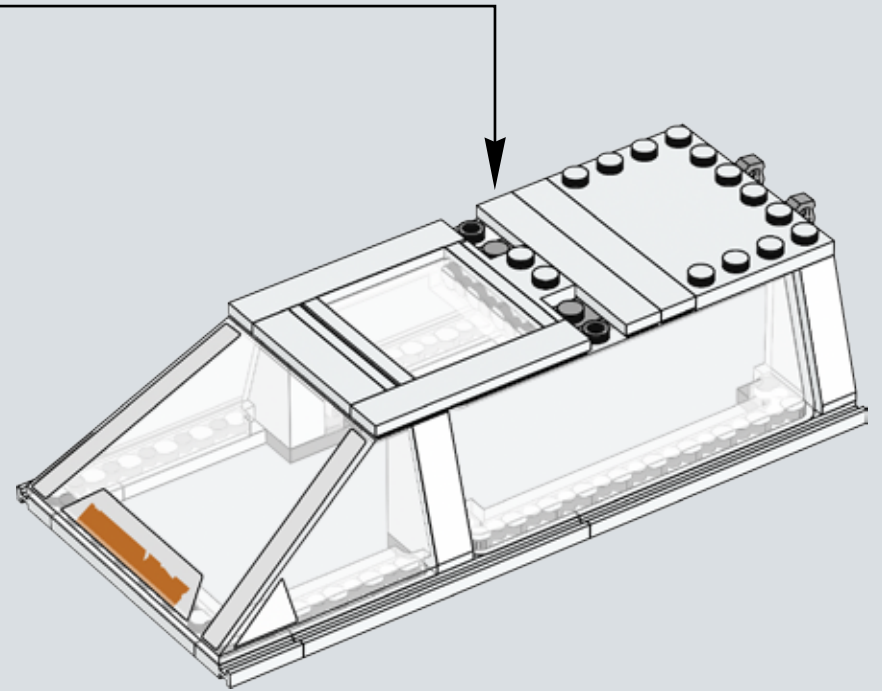



2x

460

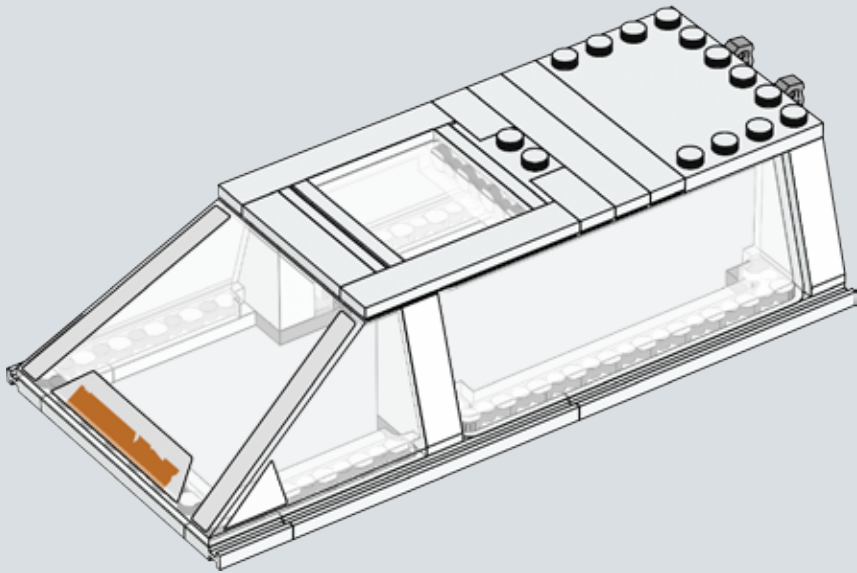

461

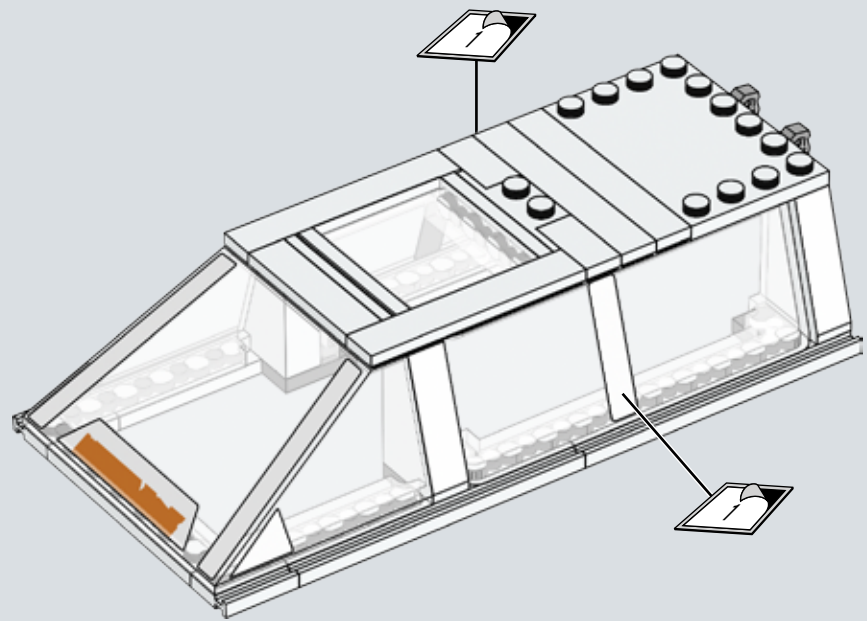

462

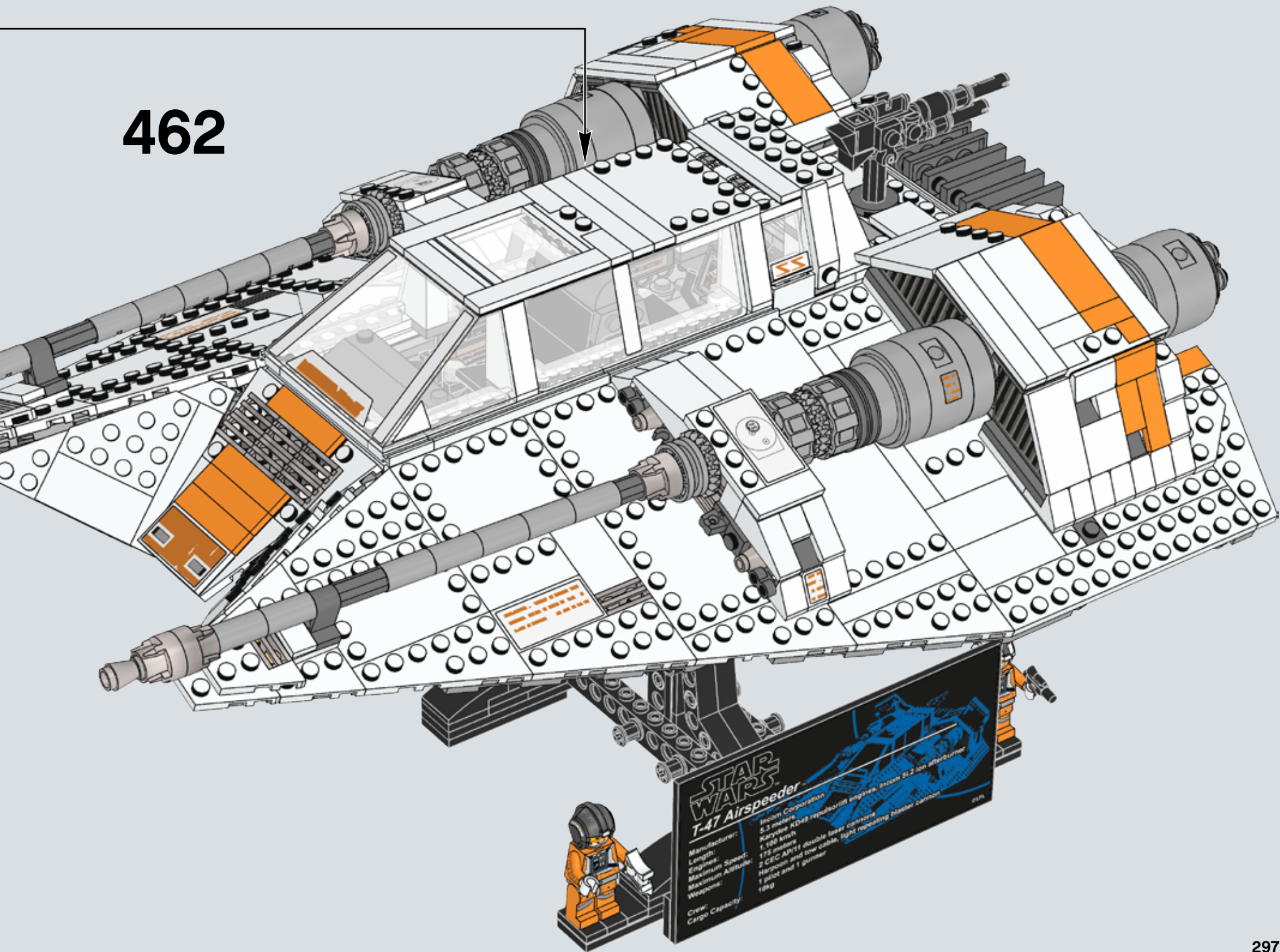

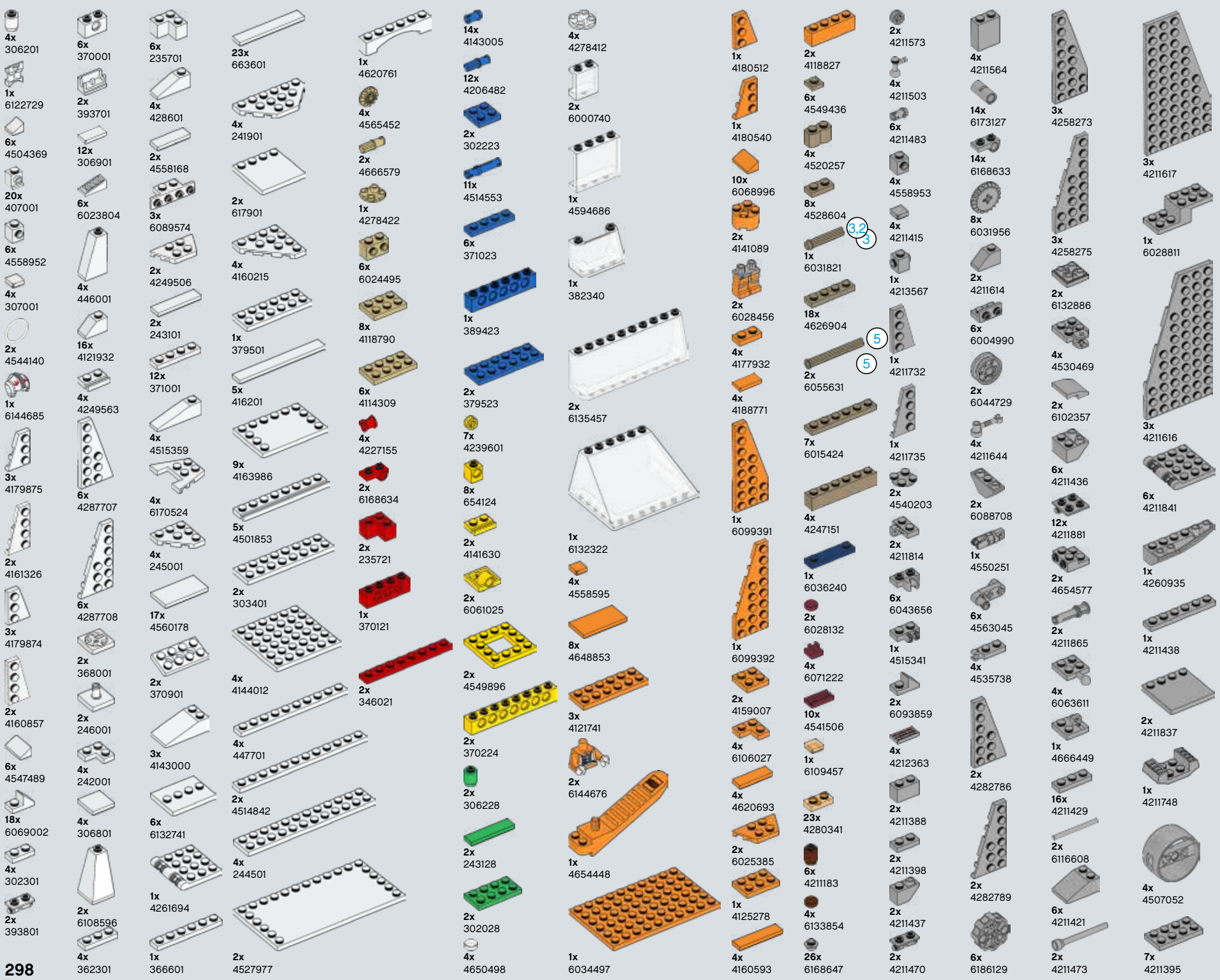

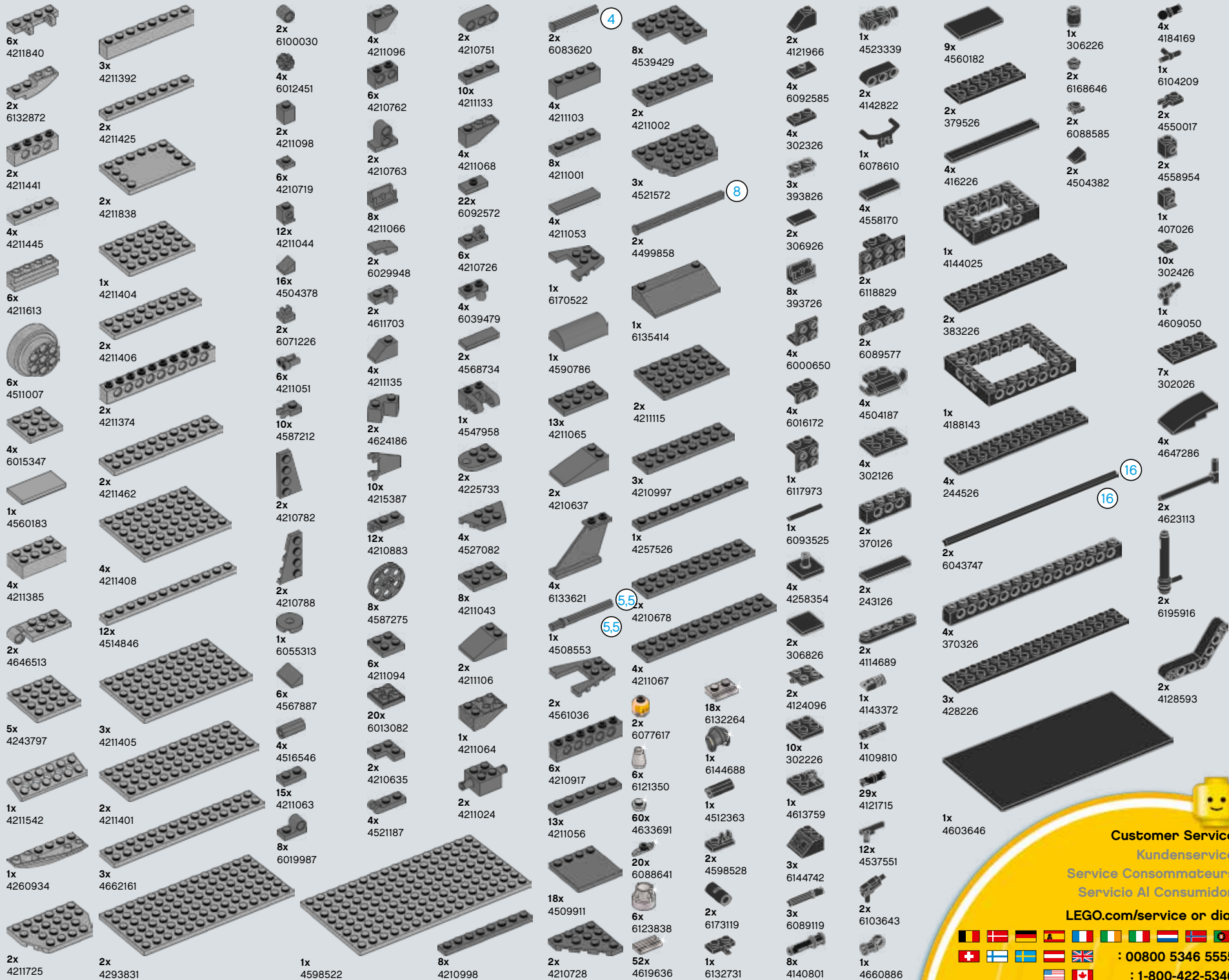



Customer Service
 Kundenservice
 Service Consommateurs
 Servicio Al Consumidor
LEGO.com/service or dial

 : 00800 5346 5555
 : 1-800-422-5346

WIN

GO TO WWW.LEGO.COM/PRODUCTFEEDBACK AND
GIVE US YOUR SHORT **FEEDBACK** ABOUT THIS
LEGO® SET FOR A CHANCE TO WIN
A COOL LEGO PRIZE.

Terms & Conditions apply



LEGO.com/productfeedback

GEWINNE

Erzähle uns auf
www.LEGO.com/productfeedback

etwas über die Erfahrungen, die
du mit diesem LEGO® Set gemacht
hast, und sichere dir die Chance
auf einen coolen LEGO Preis!

Es gelten die
Teilnahmebedingungen

GAGNE

Rends-toi sur
www.LEGO.com/productfeedback

et donne-nous quelques com-
mentaires sur ce produit LEGO®
pour avoir une chance de gagner
un prix LEGO !

Voir Conditions Générales

GANAN

Visita
www.LEGO.com/productfeedback

y envíanos tu opinión acerca de
este set LEGO®, ¡Participarás en el
sorteo de un premio LEGO!

Términos y Condiciones aplicables

获取奖品

登录
www.LEGO.com/productfeedback

给出关于此乐高®套装的简短反馈，
就有机会获得炫酷乐高奖品

《条款及条件》适用

경품 당첨 기회

www.LEGO.com/productfeedback

페이지로 이동하여 이 레고® 세트에
대한 간략한 피드백을 보내 주시고
멋진 레고 경품을 탈 수 있는 기회도
잡으십시오

약관 적용

ЗАПОЛНИ АНКЕТУ И ПОЛУЧИ ПРИЗ

Перейди по ссылке
www.LEGO.com/productfeedback

ответь всего на несколько во-
просов об этом наборе LEGO®,
и у тебя появится шанс выиграть
замечательный приз от компании
LEGO.

Применяются Условия и правила
участия